

**EATON
HEAVY DUTY
SYNCHROMESH TRANSMISSIONS**

**M.A.N
Y2772518**

**RTS 15316A-LRC, RH 'HH'
M.A.N.Part No.81.32003.6439**

Illustrated Parts List
Ersatzteilliste
Catalogue Rechange
Catalogo Ricambi
Catálogo de Piezas de Recambio

3/99

Section	English	Deutsch	Francals	Italiano	Español	Section
1 a	Maincase Assy	Gehäuse Hauptgetriebe	Ensemble carter principal	Scatola principale	Conjunto carcasa principal	1
1 b	Lubrication System	Ol-system	Huile-systeme	Olio-sistema	Accite-sistema	1b
1 c	Clutch Housing Assy	Kupplungsgehäuse	Cloche d'embrayage	Coppa frizione	Campana embrague	1c
2	Input Shaft Assy	Antriebswelle	Arbre d'entrée	Albero di entrata	Eje primario	2
3	Mainshaft Assy	Hauptwelle	Arbre principal assemblé	Alberio principale completo	Conjunto eje principal	3
4	Countershaft Assy	Vorgelegewellen	Arbre secondaire	Contralbero completo	Conjunto eje secundario	4
5	Reverse Idler Assy	Rückwärtsgang-Umkehrad	Pignon de renvoi marche AR	Ingranaggio rinvio RM	Conjunto inversor MA	5
6	Auxiliary Housing Assy	Hinteres gehäuse	Carter auxiliaire	Scatola posteriore	Tapa trasera	6
7	Auxiliary Gearing Assy	Nachschaftgruppe	Engrenage auxiliaire	Scatola ausiliaria	Sección auxiliar	7
12 a	Shift Bar Housing Assy	Schaltdeckel	Couvercle de changement de vitesse	Coperchio selettore	Tapa de varillas	12a
12 b	Range Cylinder Assy	Zylinder-schalt	Cylindre-de selection	Cilindrio-cambio	Cilindro-cambio-gamas	12b

12 c	Selector Mechanism Assy	Schalt-	Ensemble de selection	Coperchio selettore	Conjunto selectora	12c
13	Remote Control Assy	Fernschaltung	Commande a distance	Complessivo comando a distanza	Conjunto control remoto	13
14	Service kits and assemblies	Bau-und service-satze	Kits et ensembles	Corredi e complessivi de manutenzione	Juegos Y conjuntos de servicio	14

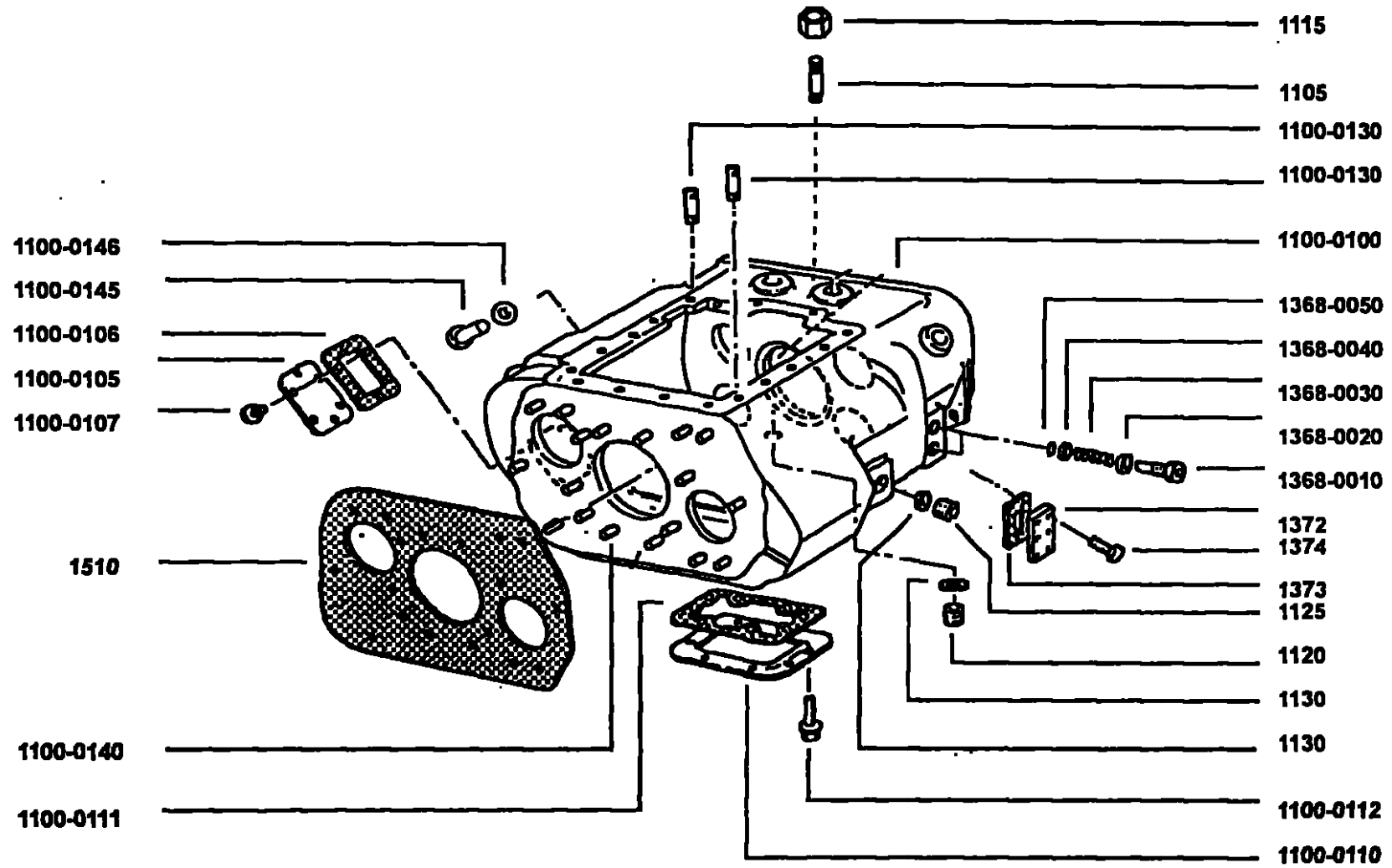

Section 1

Maincase Assembly, Gehäuse Hauptgetriebe, Ensemble Carter Principal, Scatola Principale, Conjunto Carcasa Principal
Section 1a

Sequence No Sequenz Nr Séquence No Sequela No Secuencia No	Qty Anzahl Qts Qta No.	Part No Telle Nr Piece No Rif No.Cat	English	Deutsch	Français	Italiano	Español	Stock Qty Lager Empf Qts de stockage Quantità Cant Stock
1100 0100	1	2771364	Maincase	Getriebegehäuse	Carter principal	Scatola principale	Carcasa principal	-
1100 0101	1	2772458	Insert M16	Einlage	Insert	inserto	Plaquita	-
1100 0105	1	2005144	Cover-PTO	Deckel-nebenantriebe	Couvercle de PMT	Coperchio Pdf	Tapa de la TF	-
1100 0108	1	2772047	Gasket-6 bolt PTO	Dichtung-nebenantriebe	Joint de PMT	Guarnizione Pdf	Junta de la TF	2
1100 0107	6	MX-8-1031	Screw M10 x 30	Schraube	Vis	Vite	Tornillo	-
1100 0110	1	U14082	Cover-8 Bolt PTO	Deckel-nebenantriebe	Couvercle de PMT	Coperchio Pdf	Tapa de la TF	-
1100 0111	1	2772046	Gasket-8 bolt PTO	Dichtung-nebenantriebe	Joint de PMT	Guarnizione Pdf	Junta de la TF	2
1100 0112	8	MX-8-1235	Screw M12 x 35	Schraube	Vis	Vite	Tornillo	-
1100 0130	2	2770245	Dowel	Stift	Goupille	Spina	Passador	
1100 0135	2	X2013515	Plug	Stopfen	Bouchon	Tappo	Tapon	-
1100 0140	18	2770351	Stud M12 x 50	Stiftschraube	Goujon	Prigioniero	Espárrago	-
1100 0145	1	U8876353	Oil strainer assy	Öl-Ablaschraube	Crepine	Filtro	Filtro	1
1100 0148	1	X8875280	Washer	Scheibe	Rondelle	Rondella	Arandela	1
1105	0		Stud M16 X 94	Stehbolzen	Goujon	Prigioniero	Esparrago	-
1110	0		Nut M16	Mutter	Ecou	Dado	Tuerca	-
1120	1	X8875853	Magnetic drain plug	Verschlusschraube	Bouchon	Tappo	Tap	-
1125	1	X8875854	Filter plug	Verschlusschraube	Bouchon	Tappo	Tapón	-
1130	2	X8875238	Washer	Scheibe	Rondelle	Rondella	Arandela	2
1368 0010	2	2770939	Plug	Schraube	Bouchon	Tappo	Tap	2

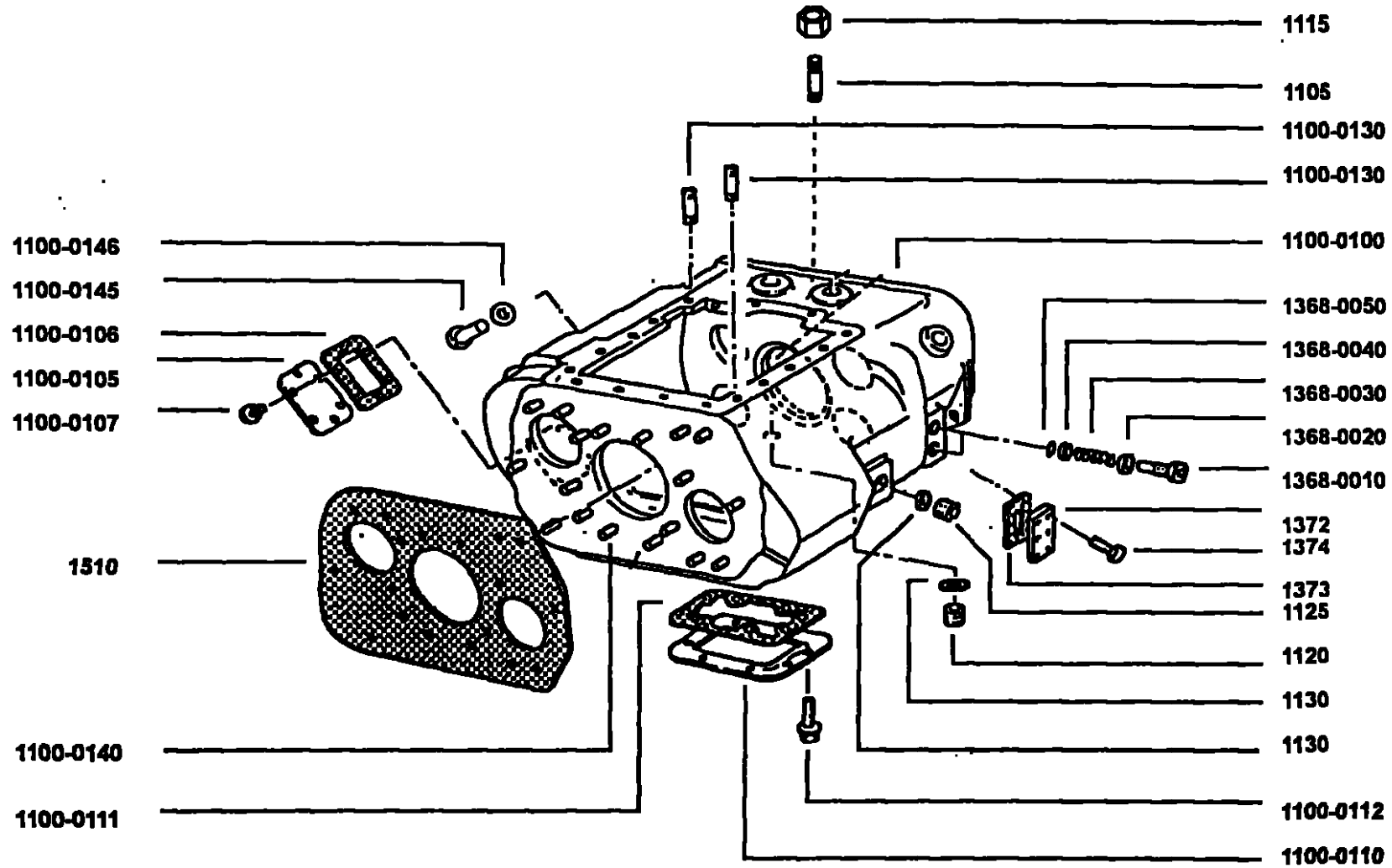

Section 1

Sequence No Sequenz Nr Séquence No Sequela No Secuencia No	Qty Anzahl Qte Qta No.	Part No Telle Nr Piece No Rif No.Cat	English	Deutsch	Francals	Italiano	Español	Stock Qty Lager Empf Qte de stockage Quantità Cant Stock
1368 0020	2	8876855	Washer	Scheibe	Rondelle	Rondella	Arandela	-
1368 0030	2	2770840	Spring	Feder	Ressort	Molla	Muelle	1
1368 0040	2	2770841	Compression ring	Scheibe	Rondelle	Rondella	Arandela	-
1368 0050	2	X2770842	"O" ring	"O" ring	Joint torique	"O" ring	Junta tórica	2
1372	1	2770843	Transfer plate	Transferplatte	Plaque de transfert	Plastrina	Placa de transferencia	-
1373	1	2770844	Gasket	Dichtung	Joint	Guarnizione	Junta	2
1374	6	MX-8-0621	Screw M8 x 30	Schraube	Vis	Vite	Tornillo	-
1375	1	U2772388	Shim kit	Distanzringsatz	Kit entretoise	Corredo distanziale	Juego de separador	1
1510	1	2770868	Gasket-clutch housing	Dichtung- kupplungsgehäuse	Joint-embayage	Guarnizione-coppa frizione	Junta-campana embrague	1
1670	0		Solenoid valve- u/s brake	Magnetventil	Solenoid de la valve	Valvola elettropn.	Valvula de solenoids	3
1675	0		Spacer	Distanzplatte	Entretoise	Piastro distanziale	Españador	-
1680	0		Bolt M8 x 75	Schraube	Vis	Vite	Tornillo	6
1685	0		Connector	Verschraubungen	Raccords	Raccordi	Racores	6

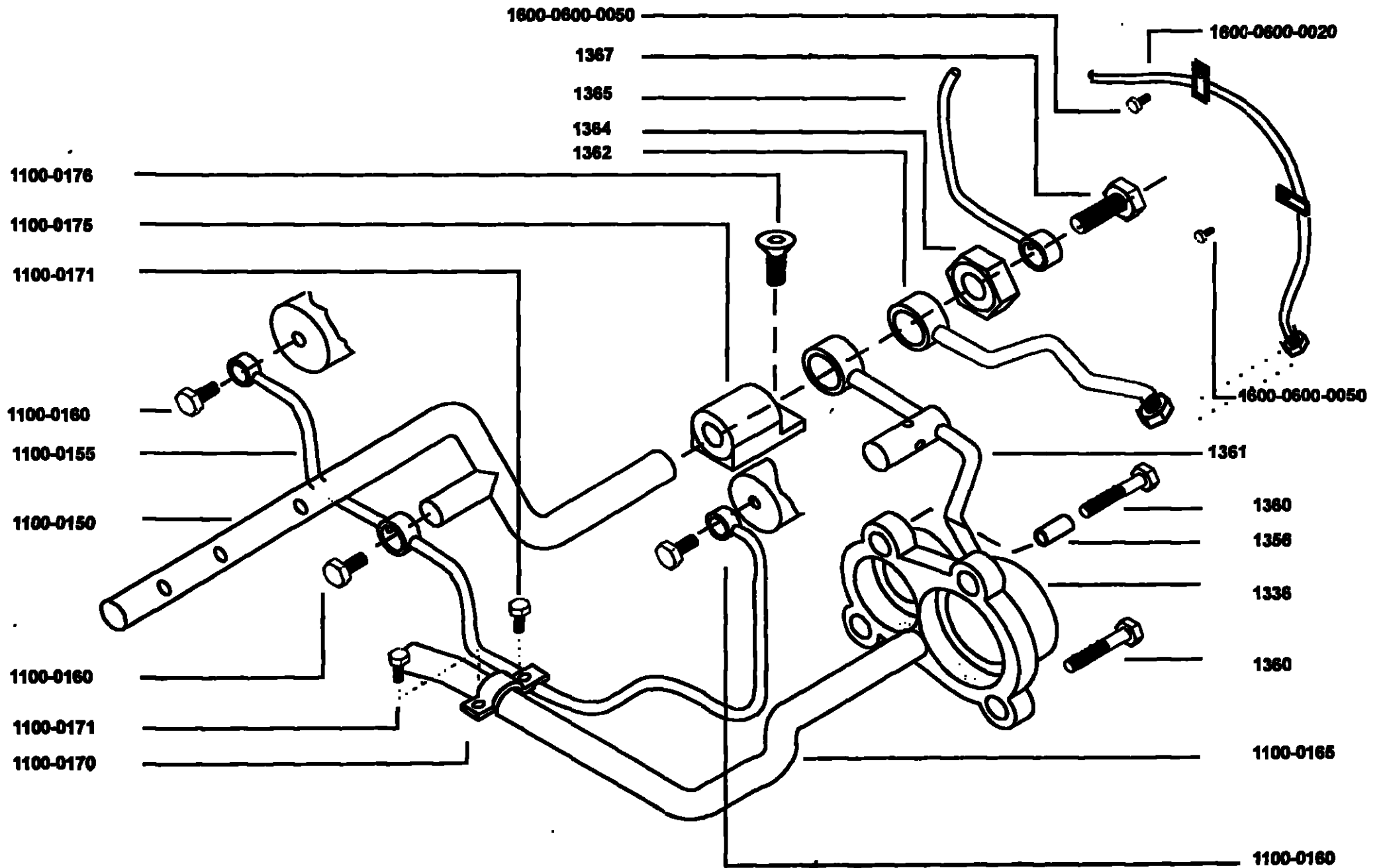

Section 1b

Sequence No	Qty	Part No	English	Deutsch	Francals	Italiano	Español	Stock Qty
1100 0150	1	2771252	Spray bar	Ole Schlauch	Tube a huile	Tube olio	Tuberia de aceite	
1100 0155	1	2771255	Supply pipe-rev.idler	Schlauch-R.gang	Tube a MA	Tube-retromarcia	Tuberia MA	-
1100 0160	3	2771259	Bolt-banjo	Schraube-	Boulon-	Bullone-	Perno-	-
1100 0165	1	2771254	Pipe-suction pump	Schlauch-pumpe	Tube a pompe	Tube-pompa	Tuberia-bomba	-
1100 0170	1	2771260	Clip	Schelle	Collier	Fascetto	Abrazadera	-
1100 0171	2	MX-8-0605	Screw M6 x 16	Schraube	Boulon	Bullone	Perno	-
1100 0175	1	2771251	Manifold	Oiverteilungsblech	Plaque de repartition d'huile	Disco diffusore	Placa distribucion de aceite	
1100 0176	1	MX-8-0626	Screw M6 x 20	Schraube	Boulon	Bullone	Perno	-
1336	1	U2771390	Oil pump assy	Olpumpe komplett	Assemblee de pompe a huile	Pompa olio-compressivo	Bomba de aceite-conjunto	1
1360	2	MX-8-1068	Screw M10 X 40	Schraube	Boulon	Bullone	Perno	-
1361	1	U2771253	Supply pipe-relief valve	Schlauch-ventil	Tube-valve	Tube-valvola	Tuberia-valvula	-
1362	1	2771256	Supply pipe-lower PTO	Schlauch-PTO	Tube-PTO	Tube-PTO	Tuberia-PTO	-
1364	1	2771258	Connector-pipe/manifold	Verdraubungen	Racords	Racordi	Racores	-
1365	1	2771257	Supply pipe-upper PTO	Schlauch-PTO	Tube-PTO	Tube-PTO	Tuberia-PTO	-
1367	1	2771259	Bolt-banjo	Schraube-	Boulon-	Bullone-	Perno-	-
1368	1	X2014173	Bushing-dowel	Buchse	Bague	Boccola	Casquillo	1
1600 0600 0020	1	U2771465	Tube assy - output bearing	Schlauch-komplett, lager	Assemblee de tube-roulement	Tube, compressivo-cuscinetto	Tuberia, conjunto-cojinete	-
1600 0600 0050	2	MX-8-0627	Screw M6 x 10	Schraube	Boulon	Bullone	Perno	-

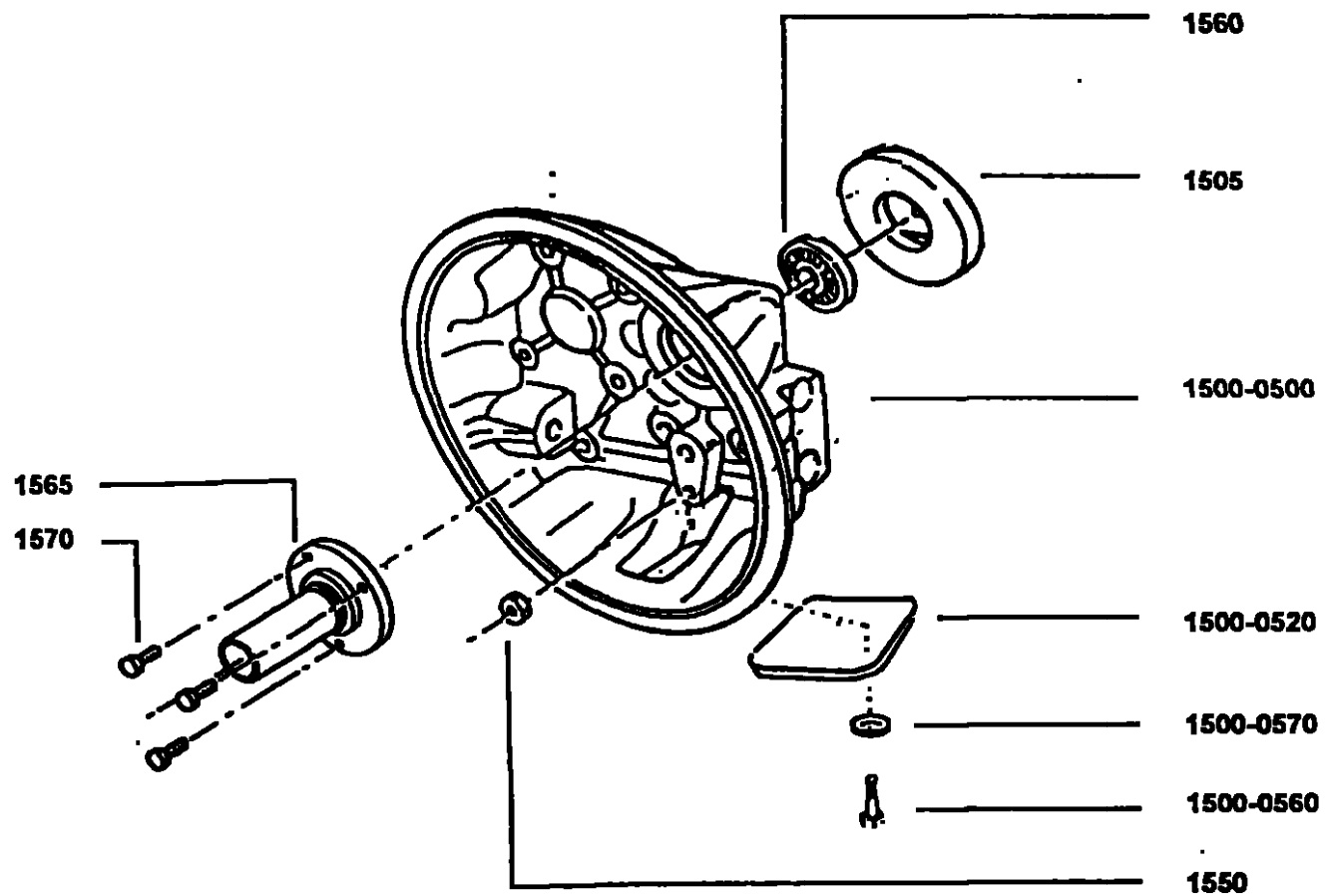

Clutch Housing Assy, Kupplungsgehäuse Komplett, Cloche d'Embrayage-assemblee, Coppa frizione-complessivo, Campana Embrague-conjunto **Section 1c**

Sequence No	Qty	Part No	English	Deutsch	Francals	Italiano	Español	Stock Qty
1500 0500	1	2772446	Clutch housing-SAE 1	Kupplungsgehäuse	Cloche d'embrayage	Campana	Tapa del embrague	-
1500 0520	1	2770149	Inspection cover	Deckel	Couvercle	Coperchio	Tapa	-
1500 0510	0		Bushing	Buchse	Bague	Boccola	Casquillo	4
1500 0530	0		Grease nipple	-	-	-	-	-
1500 0540	0		Hydraulic nipple	-	-	-	-	-
1500 0550	0		Pipe plug 1/8	Verschlusschraube	Bouchon filete	Tappo filetato	Tapon	-
1500 0560	0		Setcrew-5/16 x 14	Schraube	Vis	Vite	Tornillo	-
1500 0570	0		Lockwasher 5/16	Feddering	Rondelle grower	Rosetta elastica	Arandela elastica	-
1500 0580 0010	0		Bolt 7/16 UNC	Schraube	Boulon	Bulone	Perno	-
1500 0580 0020	0		Key	Keil	Reglette	Chiavetta	Chavete	-
1500 0580 0030	0		Shaft-short	Welle-	Axe-	Albero-	Eje-	-
1500 0580 0040	0		Yoke-clutch release	Schaltgabel	Fourchette	Forcella	Horquilla	-
1500 0580 0050	0		Cross shaft	Welle-	Axe-	Albero-	Eje-	-
1500 0580 0060	0		Lockwasher 7/16	Feddering	Rondelle grower	Rosetta elastica	Arandela elastica	-
1505	1	2771987	Oil distribution plate	Ölverteilungsblech	Plaque de repartition d'huile	Disco diffusore	Placa distribucion de aceite	-
1550	18	MX-8-1204	Nut M12	Mutter	Ecrou	Dado	Tuerca	-
1560	1	X2770218	Seal-Input shaft	Dichtung	Joint	Guarnizione	Salleja/reten	2
1565	1	2770096	Cover-Input shaft	Deckel-	Couvercle-	Coperchio-	Tapa-	-
1570	3	MX-8-0825	Bolt M8 x 25	Schraube	Vis	Vite	Tornillo	-

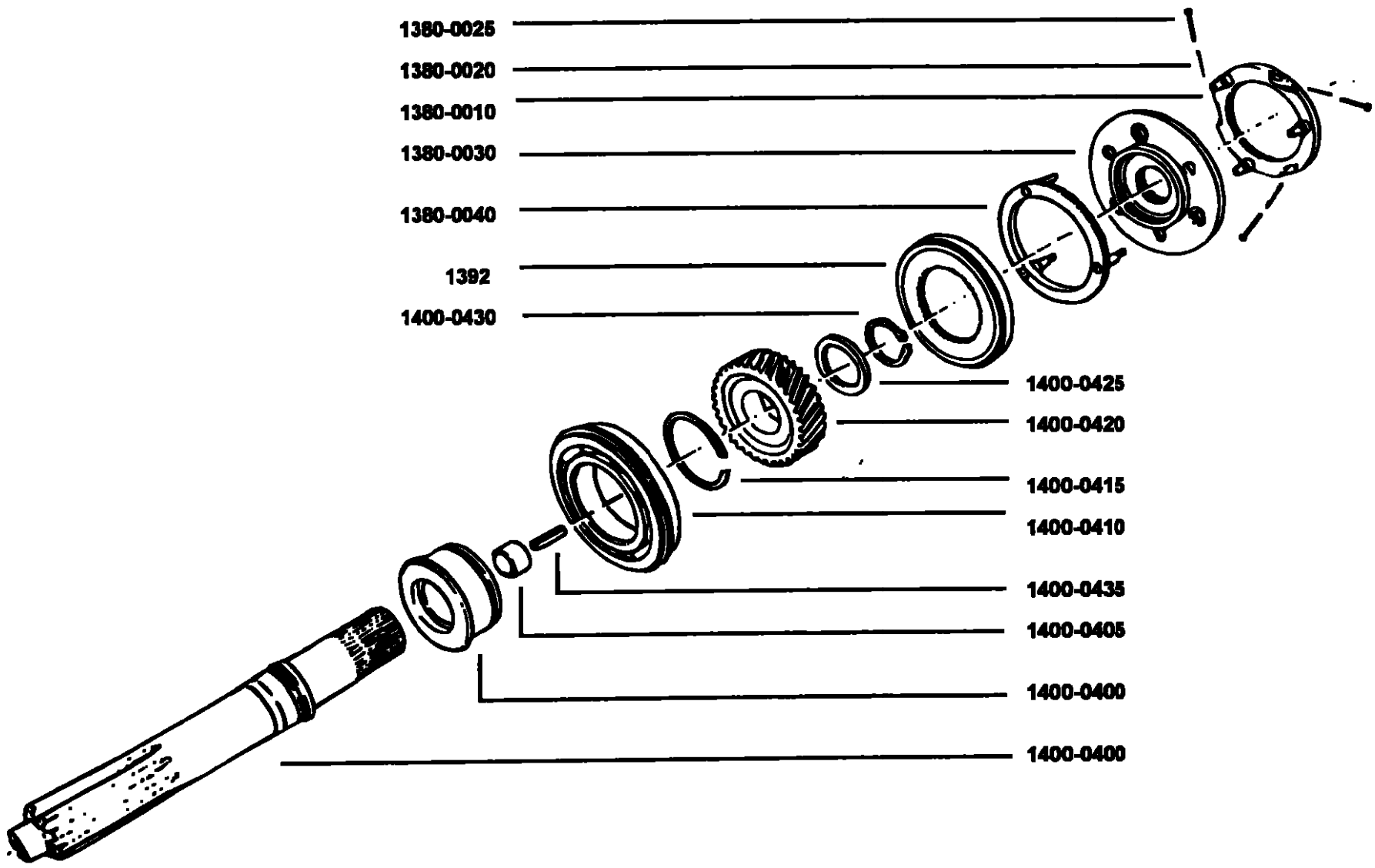

Input Shaft Assy, Antriebswelle-komplett, Arbre d'Entrée-ensemble, Albero di Entrata-complessivo, Eje Primario-conjunto
Section 2

Sequence No	Qty	Part No	English	Deutsch	Français	Italiano	Español	Stock Qty
1400	Ref.	U2771762	Input shaft assy.	-	-	-	-	-
1400 0400	1	U2771154	Input shaft and spacer	Antriebswelle	Arbre d'entrée	Albero di entrata	Eje primario	-
1400 0405	1	2770291	Bush	Buchse	Bague	Boccola	Casquillo	1
1400 0410	1	5588508	Bearing	Lager	Roulement	Cuscinetto	Cojnete	2
1400 0415	1	16722	Snap ring	Sicherungsring	Circlips	Anello elastico	Anillo elástico	2
1400 0420	1	2771723	Splitter gear	Zahnrad	Pignon	Ingranaggio	Engranaje	
1400 0425	1	2771151	Splitter gear sleeve					
1400 0430	1	X2771224	Circlip	Sicherungsring	Circlips	Anello elastico	Anillo elástico	2
1400 0435	1	2770416	Oil tube	Ölleitung	Tube d'hulle	Tubetto olio	Tuberia para el aceite	-
1380 0010	1	U2771700	Splitter assembly. Special direct U/D	Splitterkegel -direktgang	Cône/goupille directe de relais	Cono sincronizzatore riduttore	Conjunto directo cono/pasador del splitter	-
1380 0020	3	2770119	Spring	Feder	Resort	Molla	Muelle	3
1380 0025	3	2770673	Pin-Guide Spring					
1380 0030	1	2771725	Splitter clutch plate	Splitter-Kupplungsplatte	Plateau d'embrayage de relais	Disco innesto riduttore	Placa del embrague splitter	-
1380 0040	1	U2771985	Splitter cone/pin assy	Spälterkegel mit Stiften	Cône/goupille de relais	Anello sincronizzatore riduttore	Conj. cono/pasador del splitter	-
1392	1	2771695	Synchroniser cup	Synchroneglocke	Coupelle de synchro	Cono sincronizzatore	Anillo del sincronizador	-

Mainshaft, Hauptwelle, Arbre Principal Assemblé, Albero Principale Completo, Conjunto Eje Principal
Section 3

Sequence No	Qty	Part No	English	Deutsch	Français	Italiano	Español	Stock Qty
1300	Ref	U2772542	Mainshaft assy					-
1300 0300	1	2771583	Mainshaft	Hauptwelle	Arbre principal	Albero principale	Eje principal	-
1300 0304	1	82504	Pin	Stift	Goupille	Spina	Pasador	-
1300 0308	1	2771480	Key-mainshaft	Keil	Reglette	Chiavetta	Chaveta	-
1300 0316	1	Z2772487	1st gear	1.-Gangrad	Pignon de 1ère	Ingranaggio 1'vel	Enganaje 1'	-
1300 0324 0010	1	U2770851	1/2 gear synchro assy	Synoronsatz 1./2. Gang	Synchro de 1ère et 2ème	Compl. sincronizzatore 1/2 vel	Conj. sincronización de 1'/2'	1
1300 0324 0020	3	2770113	Pre-energising plunger	Schieber	Plongeur	Nottilino	Vástago	3
1300 0324 0030	3	2770200	Spring	Feder	Ressort	Molla	Muelle	1
1300 0324 0050	1	2770663	1/2 gear sliding clutch	Schiebemuffe 1./2. Gang	Crabot de 1ère et 2ème	Manicotto scorrevole 1/2 vel	Carrete de 1'/2'	1
1300 0324 0060	1	2770664	Sliding clutch-1st/2nd	Schiebemuffe 1./2 gang	Crabot-1ere/2nde	Manicotto scorrevole 1/2	Carrete-1a/2a	1
1300 0324 0070	3	2770665	Retainer	Riegel	Clavette de crabot	Tassello	Retenedor	-
1300 0332	1	2770771	2nd gear	2. Gangrad	Pignon 2ème	Ingranaggio 2' velocità	Engranaje 2'	-
1300 0340	1	2772376	3rd gear	3. Gangrad	Pignon 3ème	Ingranaggio 3' velocità	Engranaje 3'	-
1300 0344	2	2771401	Synchroniser cup	Kupplungstück	Coupelle de synchro	Cono sincronizzatore	Anillo del sincronizador	1
1300 0348	5	2770783	Mainshaft thrust washer	Hauptwellen - Druckscheibe	Rondelle de poussée d'arbre principal	Rondella di spallamento albero principale	Arandela de empuje del eje principal	1
1300 0352 0010	1	U2770884	3/4 gear synchro assy	Synoronsatz 3/4. Gang	Synchro de 3ème/4ème	Compl. sincronizzatore 3/4 vel	Conj. sincronización de 3'/4'	1

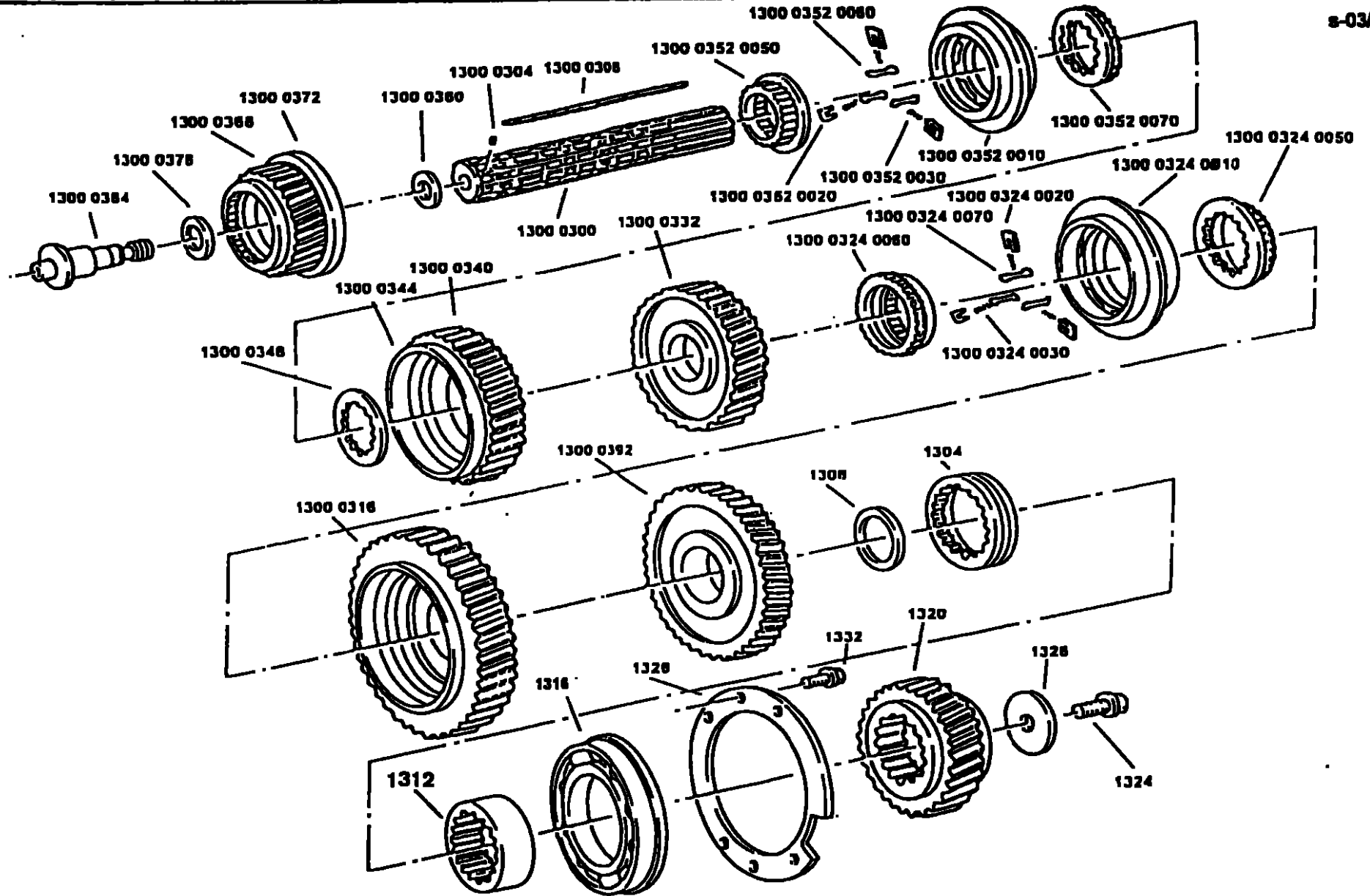

Sequence No	Qty	Part No	English	Deutsch	Français	Italiano	Español	Stock Qty
1300 0352 0020	3	2770113	Plunger	Boizen	Pionneur	Nottolino	Vástago	3
1300 0352 0030	3	2770200	Spring	Feder	Ressort	Molla	Muelle	3
1300 0352 0050	1	2770748	3/4 gear sliding clutch	Schiebemuffe 3/4. Gang	Crabot de 3ème et 4ème	Manicotto sincronizzatore 3/4	Carrete de 3'/4'	1
1300 0352 0080	3	2770278	Retainer	Riegel	Clavette de crabot	Fermo	Retenedor	-
1300 0352 0070	1	2770748	3/4 gear sliding clutch	Schiebemuffe 3/4. Gang	Crabot de 3ème et 4ème	Manicotto sincronizzatore 3/4	Carrete de 3'/4'	1
1300 0380	1	2770774	Thrust washer	Druckscheibe	Rondelle de poussée	Rondella di spallamento	Arandela de empuje	1
1300 0388	1	2772377	4th gear	4. Gangrad	Pignon 4ème	Ingranaggio 4' velocità	Engranaje 4'	-
1300 0378	2	2770780	Thrust bearing	Drucklager	Paler axial	Cuscinetto raggispinta	Conjnete de empuje	1
1300 0384	1	2771405	Mainshaft spindle	Hauptwellenspindel	Broche d'arbre principal	Perno filettato	Huallio del eje principal	-
1300 0392	1	Z2772488	Reverse gear	RW.-Gangrad	Pignonde marche AR	Ingranaggio retromarcia	Engranaje MA	-
1304	1	2770442	Reverse sliding clutch	Schiebemuffe RW.-Gang	Crabot de marche AR	Manicotto retromarcia	Carrete MA	-
1308	1	2770247	Thrust washer	Distanzring	Entretoise	Distanziale	Separador	-
1312	1	2771845	Bearing spacer	Lagerdistanzring	Entretoise de roulement	Distanziale cuscinetto	Conjnete separador	-
1318	1	5588508	Bearing	Lager	Roulement	Cuscinetto	Cojinete	2
1320	1	2770289	Mainshaft auxiliary drive gear	Antrieberad Nachschaltgruppe	Pignon de transmission auxiliaire d'arbre principal	Ingranaggio conduttore ausiliario albero principale	Engranaje de accionamiento auxiliar del eje principal	-
1324	1	MX-7-1808	Screw M18 x 45	Schraube	Vis	Vite	Tornillo	-
1326	1	2770008	Retainer plate	Haltscheibe	Rondelle de retenue	Disco di fermo	Placa retenedora	-
1328	1	2770838	Bearing retainer	Lager-Haltplatte	Entretoise de roulement	Portacuscinetto	Retenedor del conjnete	-
1332	8	MX-8-1081	Screw M10 x 30	Schraube	Vis	Vite	Tornillo	-

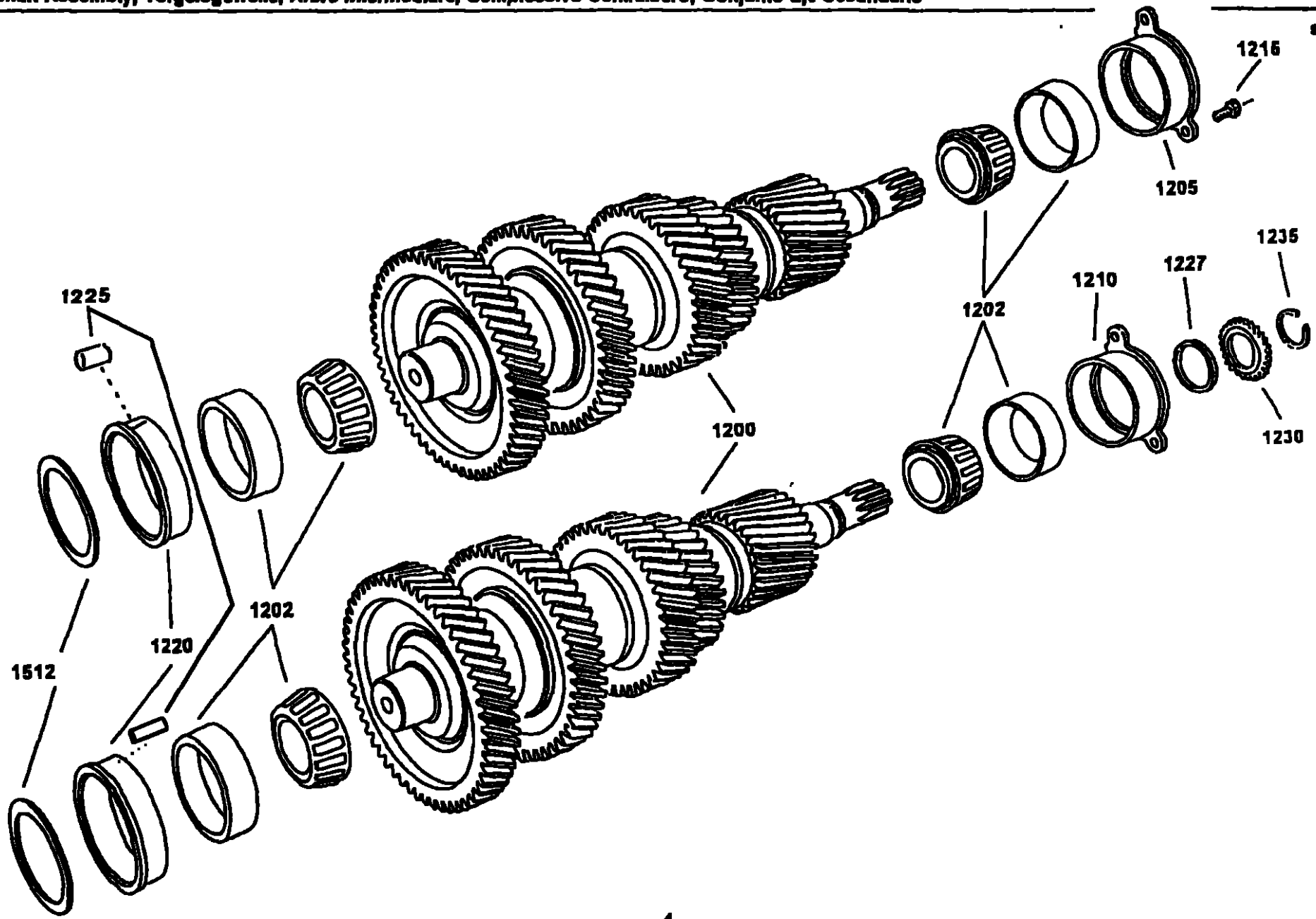

Countershaft Assemblies, Vorgelegewellen, Arbre Secondaire, Contralbero Completo, Conjunto Eje Secundario
Section 4

Sequence No	Qty	Part No	English	Deutsch	Français	Italiano	Español	Stock Qty
1200	2	ZU2772507	Countershaft assy	Vorgelegewellen	Arbre secondaire	Compl. contralbero	Conjunto eje secundario	-
1202	4	X2770467	Bearing	Lager	Roulement	Cuscinetto	Cojinete	2
1205	1	2770311	Rear upper bearing retainer	Hinterer oberer Lagerhalter	Bague de retenue de roulement superieur AR	Portacuscinetto posteriore superiore	Retenedor del cojinete superior trasero	-
1210	1	2770644	Rear lower bearing retainer	Hinterer unterer Lagerhalter	Bague de retenue de roulement inferieur AR	Portacuscinetto posteriore inferiore	Retenedor del cojinete inferior trasero	-
1216	6	MX-B-1031	Screw M10 x 30	Schraube	Vis	Vite	Tornillo	-
1220	2	2770312	Front bearing sleeve	Hülse des vorderen Lagers	Anneau de roulement AV	Portacuscinetto anteriore	Casquillo del cojinete delantero	-
1226	1	X2770313	Roller 5mm	Verriegelungsrolle	Rouleau	Rullo	Rodillo	2
1227	1	2770340	Spacer	Distanzscheibe	Entretoise	Distanziale	Separador	-
1230	1	4302792	Gear-pump drive	Pumpentrieberad	Pignon de pompe	Pignone- pompa	Engranaje de bomba	-
1235	1	4302082	Snap ring	Sicherungering	Circlips	Anello elastico	Anillo elástico	2
1512	2	U2772388	Shim kit	Distanzringe	Kit entretoises	Corredo distanziale	Juego espaciador	2

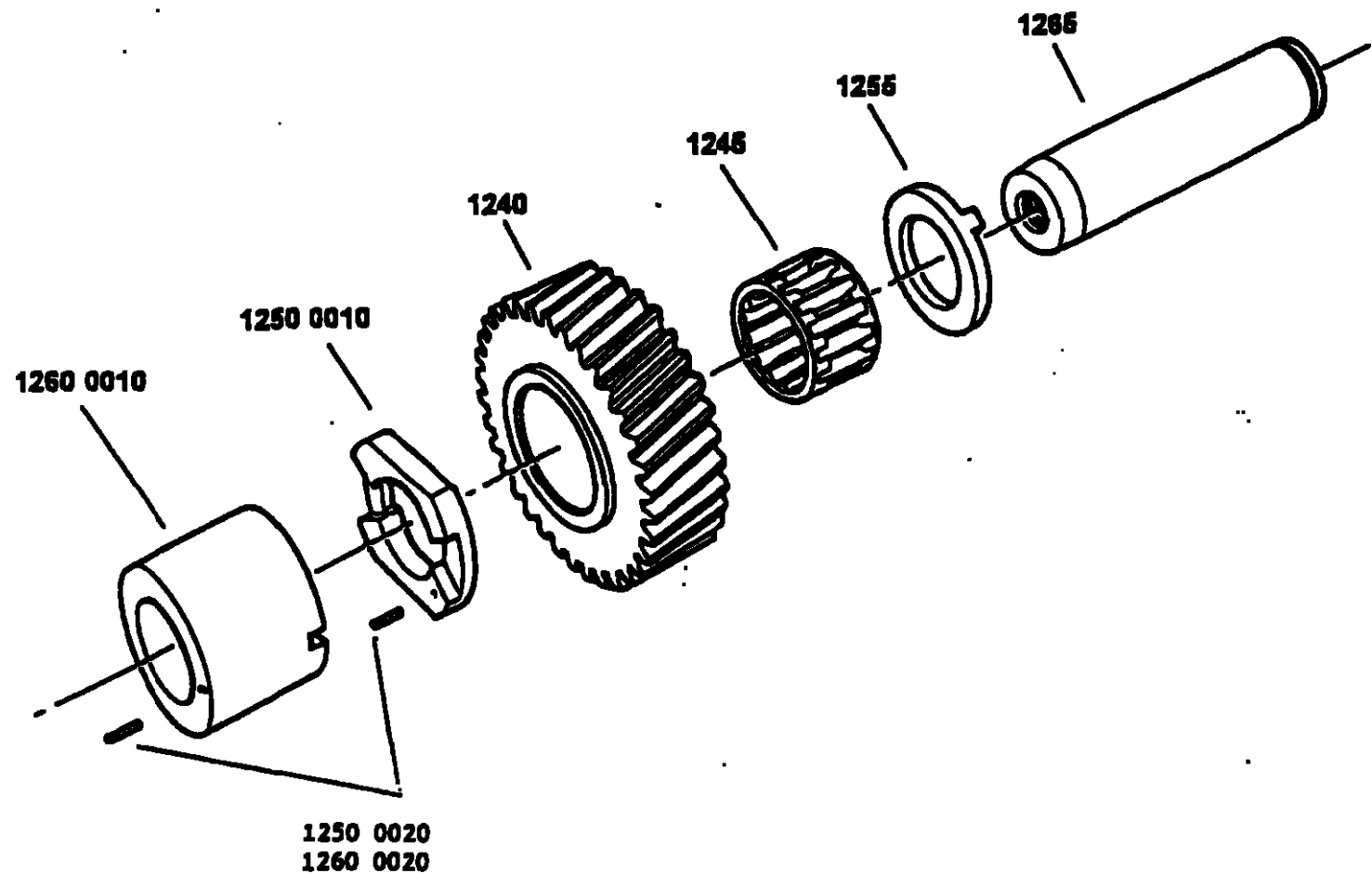

Reverse Idler, Rückwärtsgang-Umkehrad, Pignon de Renvoi Marche AR, Ingranaggio Rinvio RM, Conjunto Inversor MA**Section 5**

Sequence No	Qty	Part No	English	Deutsch	Français	Italiano	Español	Stock Qty
1240	2	2770027	Idler Gear	Zahnrad	Pignon	Ingranaggio	Engranaje	-
1245	2	X2770094	Bearing	Lager	Roulement	Cuscinetto	Cofinets	2
1250 0010	2	2770024	Thrust washer	Anlaufscheibe	Rondelle de poussée	Rondella di spallamento	Arandela de empuje	1
1250 0020	2	62504	Pin	Stift	Goupille	Spina	Pasador	-
1255	2	2770025	Thrust washer	Anlaufscheibe	Rondelle de poussée	Rondella di spallamento	Arandela de empuje	1
1260 0010	2	2770317	Spacer	Distanzhülse	Entretoise	Distanziale	Separador	-
1260 0020	2	62504	Pin	Stift	Goupille	Spina	Pasador	-
1265	2	2770732	Reverse idler shaft	Achse Rückwärtsgang-Umkehrad	Arbre de pignon de renvoi de marche AR	Alberino rinvio RM	Eje interno marcha atrás	-

Rear Case Assembly, Nachschaltgruppen-Gehäuse, Carter Arriere Assemble, Comlessivo Scatola posteriore, Conjunto Tapa Trasera

s-06/1-04

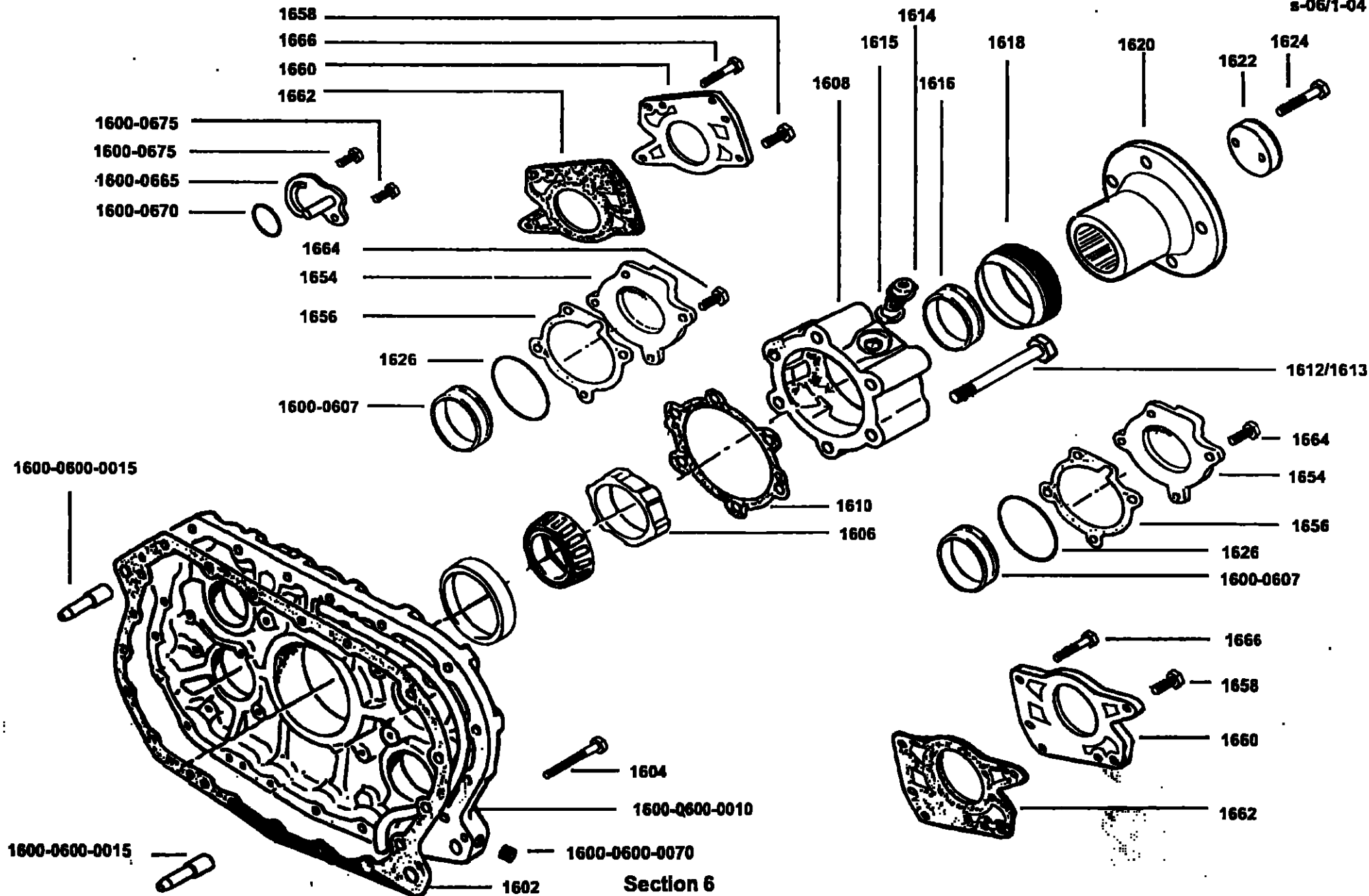

Auxiliary Housing, Nachschaltgruppe, Carter Auxiliaire, Scatola Ausiliaria, Sección Auxiliar
Section 6

Sequence No	Qty	Part No	English	Deutsch	Francais	Italiano	Español	Stock Qty
1600	Ref	U2771478	Rear case assy	-	-	-	-	-
1600 0600	Ref	U2770966	Rear housing sub-assy	Gehäuse Nachschaltgruppe-	Couvercle AR	Coperchio posteriore	Conjunto tapa trasera	-
1600 0600 0010	1	2771181	Housing rear case	Hinteres gehäuse	Carter auxiliaire	Scatola posteriore	Tapa trasera	-
1600 0600 0015	2	2771029	Dowel	Passstift	Goupille	Grano	Espiga	2
1600 0600 0075	1	X2013517	Plug 1/8 PTF	Stopfen	Bouchon	Tappo	Tapon	-
1600 0600 0076	1	X2013515	Plug	Stopfen	Bouchon	Tappo	Tapon	-
1600 0665	1	U2772123	Yoke bar cover	Schaltstangendeckel	Couvercle de barra de fourchette	Coperchietto selettore	Tapa barra de la horquilla	-
1600 0670	1	5588506	"O" ring	"O" ring	Joint torque	"O" ring	Junta tórica	2
1600 0675	2	MX-8-0825	Screw M8 x 25	Schraube	Vis	Vite	Tornillo	-
1604	16	MX-8-1070	Setcrew M10 x 55	Schraube	Vis	Vite	Tornillo	-
1606	1	2770471	Speedometer rotor	Tachometerrotor	Rotor de tachymètre	Rotore tachimetro	Rotor del velocímetro	-
1608	1	2771436	Cover-rear bearing	Tachometergehäuse	Boîter de tachymètre	Supporto tachimetro	Alojamiento del velocímetro	-
1610	1	2770878	Gasket-rear brg cover	Dichtung-tachometergehäuse	Joint-boîter de tachymetre	Guarnizione-supporto tachimetro	Junta - alojamiento del velocímetro	2
1612	5	MX-8-1030	Screw M10 x 70	Schraube	Vis	Vite	Tornillo	-
1613	1	MX-8-1044	Screw M10 x 70	Schraube	Vis	Vite	Tornillo	-
1614	1	2771835	Impulse transmitter	Drehzahlsensor komplett	Captur de vitesse	Sensore de velocità	Sensor de velocidad	-
1615	1	X2014116	Protective cap	Deckel	Couvercle	Coperchio	Tapa	-
1616	1	2770005	Spacer	Distanzstück	Entretoise	Distanziale	Separador	-
1618	1	X2770491	Seal-output	Dichtring	Joint	Guarnizione	Selleje	2
1620	1	2770484	Coupling flange	Abtriebsflansch	Bride de sortie	Flangia di uscita	Brida de salida	-

Rear Case Assembly, Nachschaltgruppen-Gehäuse, Carter Arriere Assemble, Comlessivo Scatola posteriore, Conjunto Tapa Trasera

s-06/1-04

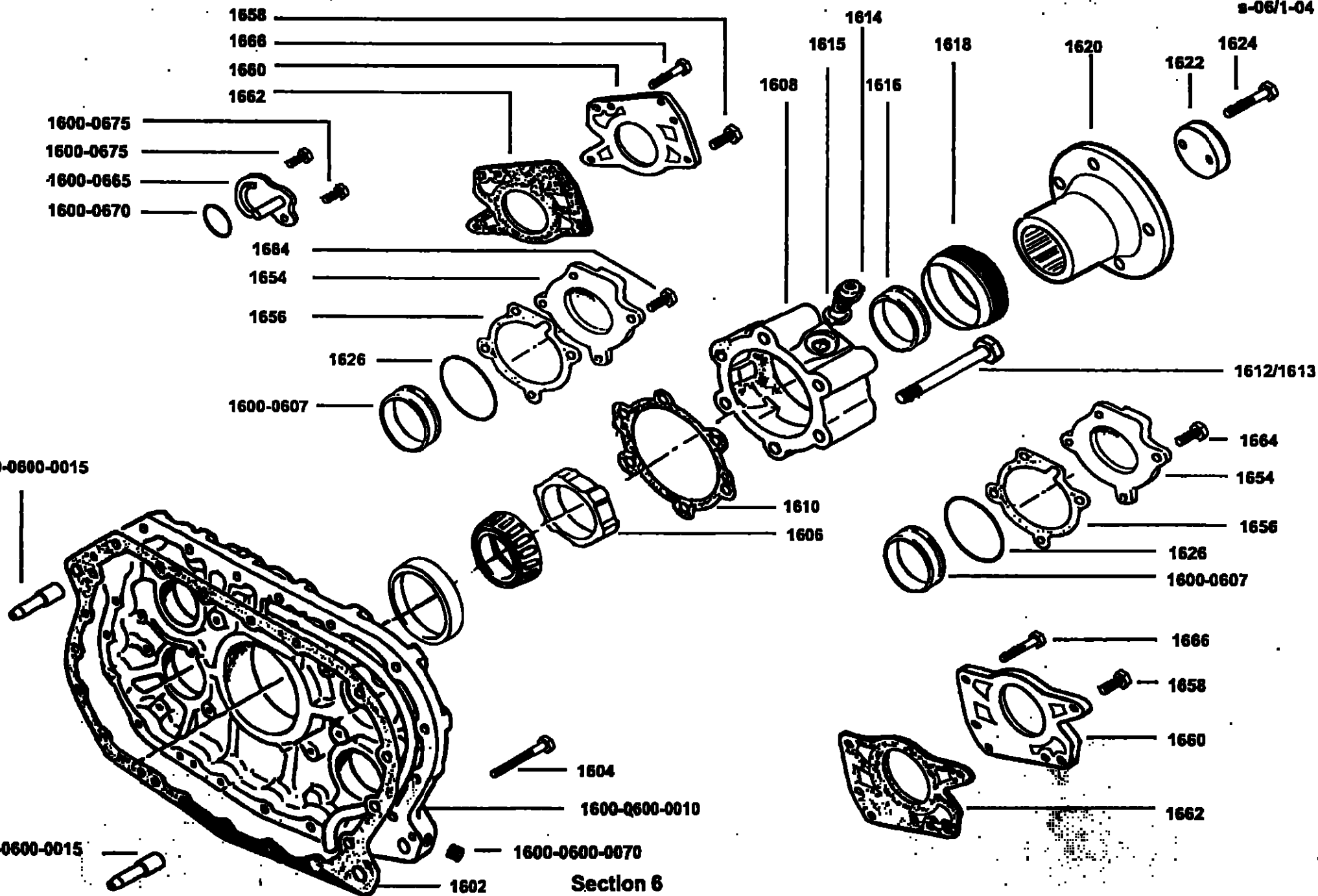

Sequence No	Qty	Part No	English	Deutsch	Français	Italiano	Español	Stock Qty
	OR							
1620	0		Yoke-1760 Series	Schaltgabel 1760	Fourchette 1760	Forcella 1760	Horquilla 1760	-
1622	1	2770417	Clamp plate	Halteplatte	Plaque de serrage	Disco di fermo	Placa de la brida	-
1624	2	MX-7-1202	Screw M12 x 60	Schraube	Vis	Vite	Tornillo	-
1626	1	U2772388	Shim kit	Distanzringe	Kit entretoises	Corredo distanziale	Juego espaciador	1
1654	2	4302320	Auxiliary countershaft bearing cover	Lagerdeckel Nachschaltgruppen Vorgelegwelle	Couvercle de roulement de transmission auxiliaire	Coperchio cuscinetto contralbero ausiliario	Tapa del cojinete auxiliar del eje secundario	-
1656	2	2772056	Gasket-rear bearing cover	Dichtung	Joint	Guarnizione	Junta	2
1658	17	MX-8-1047	Screw M10 x 35	Schraube M10 x 35	Vis M10 x 35	Vite M10 x 35	Tornillo M10 x 35	-
1659	-	X11406	LOCTITE RTV3	LOCTITE RTV3	LOCTITE RTV3	LOCTITE RTV3	LOCTITE RTV3	-
1660	2	2770345	PTO cover	Deckel nebenantriebe	Couvercle de PMT	Coperchio PdF	Tapa de la TF	-
1662	2	2770346	Gasket PTO cover	Dichtung-nebenantriebe	Joint de PMT	Guarnizione PdF	Junta de la TF	2
1666	3	MX-8-1015	Screw M10 x 90	Schraube M10 x 90	Vis M10 x 90	Vite M10 x 90	Tornillo M10 x 90	-
1668	3	X11245	Washer M10	Scheibe M10	Rondelle M10	Rondella M10	Arandela M10	-

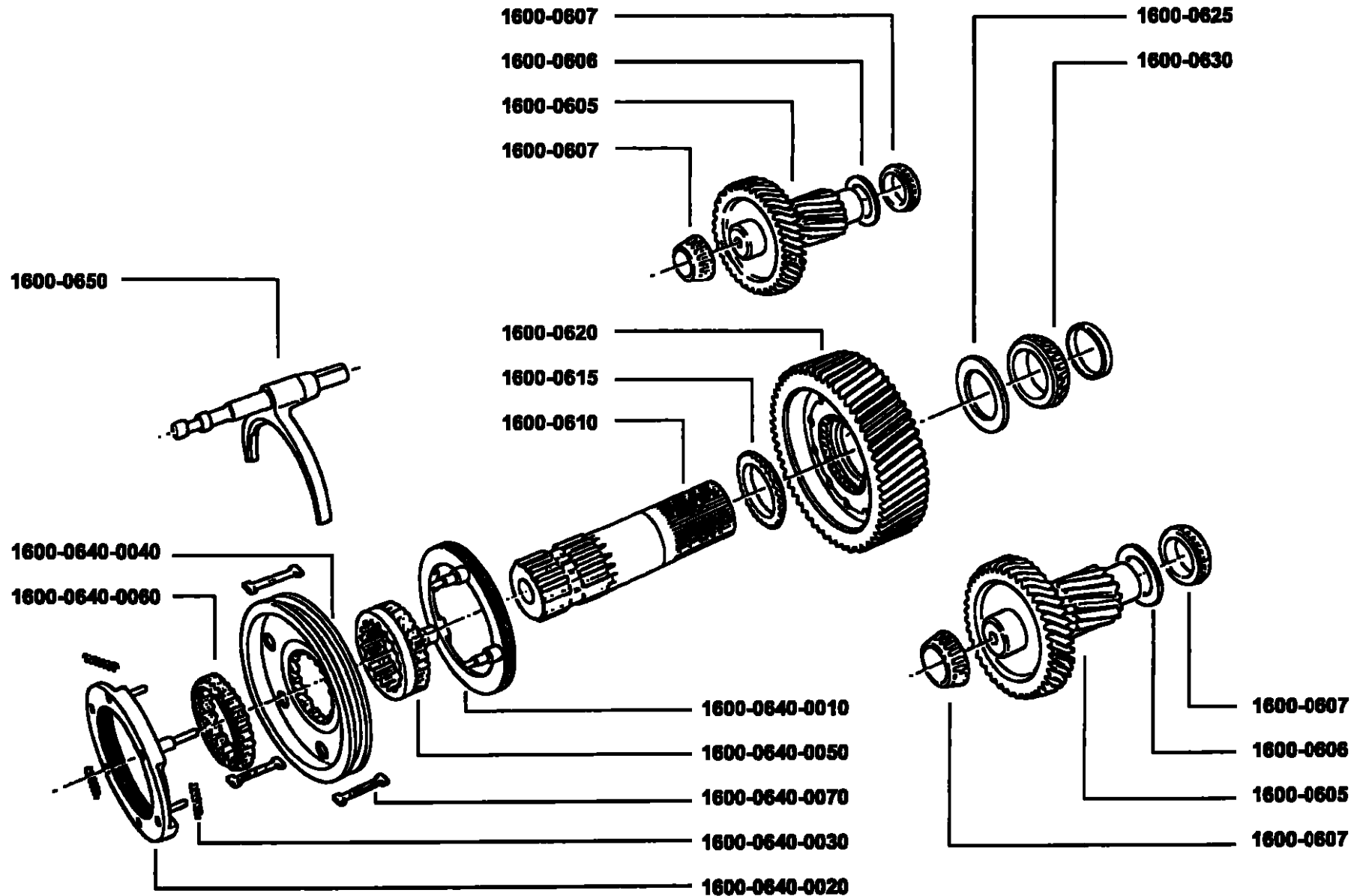

Section 7

Sequence No	Qty	Part No	English	Deutsch	Français	Italiano	Español	Stock Qty
1800 0805	2	U2771185	Auxiliary countershaft assy	Vorgelegewelle Nachschaltgruppe kompl.	Arbre secondaire auxiliaire	Contralbero auxiliar	Conjunto auxiliar de eje secundario	-
1800 0810	1	2771423	Auxiliary mainshaft	Nachschaltgruppen- Hauptwelle	Arbre principal auxiliaire	Albero auxiliar	Eje principal auxiliar	-
1800 0815	1	2771424	Splined washer	Nutenscheibe	Rondelle cannelée	Rondella dentata	Arandela postiza	-
1800 0820	1	2771810	Reduction gear	Untersetzungsrad	Pignon de réduction	Ingranaggio riduttore	Engranaje de reducción	-
1800 0825	1	2771425	Thrust washer	Druckscheibe	Rondelle de poussée	Rondella di spallamento	Arandela de empuje	1
1800 0830	1	5556503	Auxiliary mainshaft brg	Lager Nachschaltgruppen Hauptwelle	Roulement d'arbre principal auxiliaire	Cuscinetto albero auxiliario	Cojinete auxiliar del eje principal	-
1802	1	2770945	Gasket-rear heg	Dichtung	Joint	Guarnizione	Junta	1
1800 0808	2	2770172	Retaining washer	Distanzstück	Entretoise	Distanziale	Separador	-
1800 0807	4	21343	Bearing	Lager	Roulement	Cuscinetto	Cojinete	2
1800 0840 0010	1	U2771411	Range reduction synchroniser assy	Synchronring untersetzter Bereich	Synchro de réduction de gamme	Sincronizzatore gamma	Conjunto de sincronización de reducción de gama	1
1800 0840 0020	1	U2771329	Range direct synchroniser assy	Synchronring Direktbereich	Synchro direct de gamme	Compl. sincronizzatore gamma	Conjunto del sincronizador directo de gama	1
1800 0840 0030	3	14897	Spring	Feder	Ressort	Molla	Muelle	3
1800 0840 0040	1	2771330	Clutch plate	Kupplungscheibe	Plaque d'embrayage	Disco di innesto	Placa de embrague	-
1800 0840 0050	1	2771808	Range reduction clutch	Kupplung untersetzter Bereich	Crabot de réduction de gamme	Manicotto riduttore	Embrague de reducción de gama	-
1800 0840 0060	1	2770654	Range direct clutch	Kupplung Direktbereich	Crabot direct de gamme	Manicotto presa diretta	Embrague directo gama	-
1800 0840 0070	3	2770281	Range retainer	Bereichs-Riegel	Clavette de crabot	Tasselli	Retenedores de gama	3
1800 0850	1	U2772136	Range yoke assy- (MERIT)	Bereichs-schaltgabel, komplett	Assemblée de fourchette de gamme	Forcella cambio gamma- complessivo	Horquilla de gama- conjunto	-

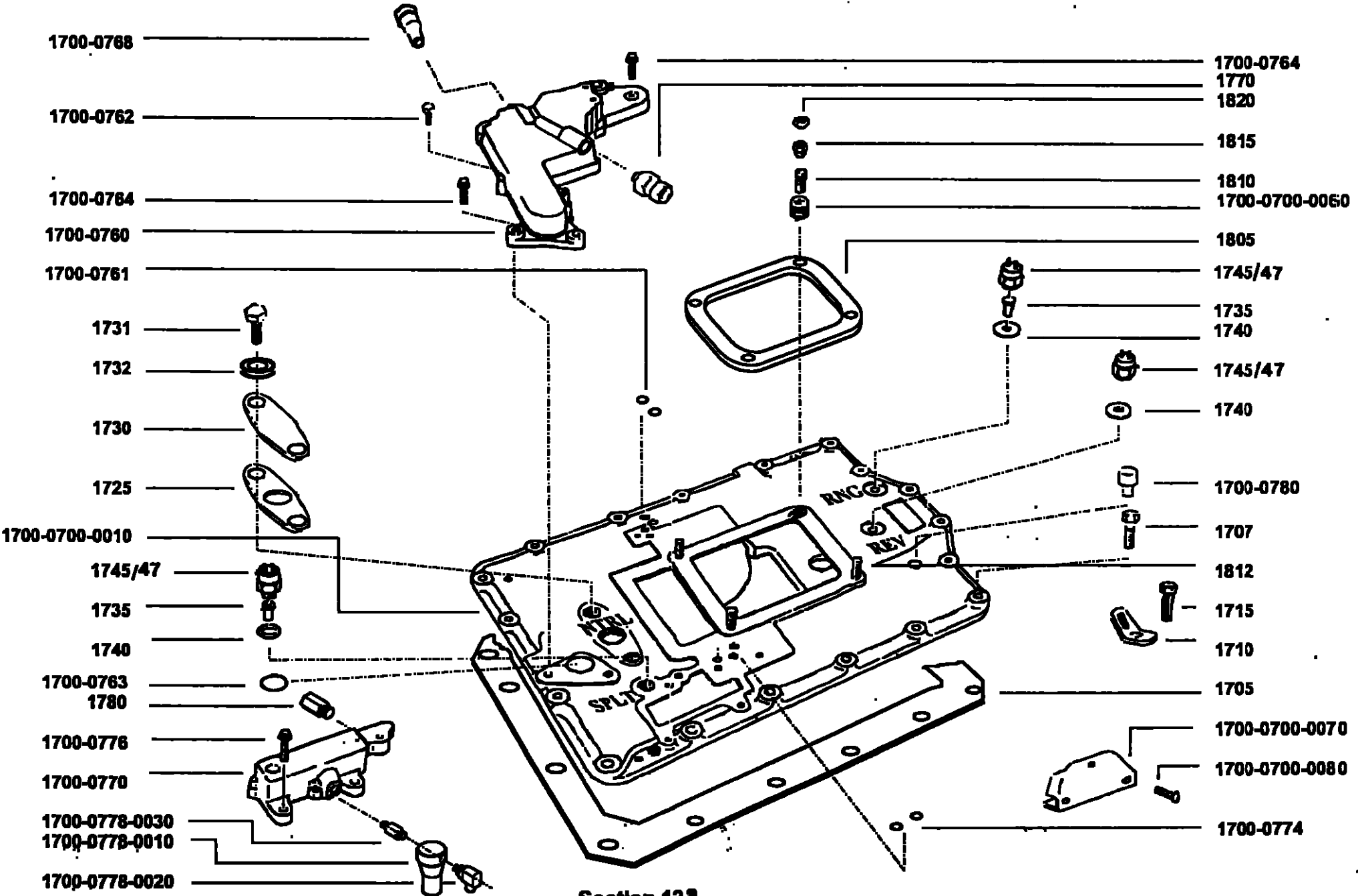

Section 12

Shift Bar Housing, Schaltdeckel, Couvercle de Changement de Vitesse, Coperchio Selettore, Tapa de Varillas
Section 12a

Sequence No	Qty	Part No	English	Deutsch	Francais	Italiano	Español	Stock Qty
1700	Ref.	U2772471	Shift housing bar assy.	Schaltdeckel	Couvercle de changement de vitesse	Coperchio selettore	Tapa de varillas	-
1700 0700 0010	1	2771162	Shift bar housing	Schaltdeckel	Couvercle de changement de vitesse	Coperchio selettore	Tapa de varillas	-
1700 0700 0015	0		Plug-special	Stopfen-	Bouchon-	Tappo-	Tapon-	1
1700 0700 0060	4	X2770323	Insert M10	Einlage	Insert	Inserto	Plaquita	-
1700 0700 0070	1	2771146	Baffle plate-breather	Platte-entluffer	Plaque-ranillard	Plastra-sfiatatoi	Placa-respiro	-
1700 0700 0080	3	X8872604	Screw 7/32 x 0.50	Schraube	Boulon	Bullone	Perno	-
1700 0780	1	A-6395	Range module 16 spd, 'H-H'	Bereichs-Modul	Module de gamme	Commando selezione gamma	Modulo de gama	1
1700 0781	2	14197	"O" ring	"O" ring	Joint	Guarnizione toroidale	Junta torica	2
1700 0782	4	MX-8-0826	Screw M8 x 30	Schraube M8 x 30	Vis M8 x 30	Vite M8 x 30	Tornillo M8 x 30	-
1700 0783	1	15569	"O" Ring	"O" Ring	Joint	Guarnizione toroidale	Junta torica	2
1700 0785	0		Pipe clip 4mm	Schelle	Collier	Fascetto	Abrazadera	-
1700 0788	1	U2771380	Adaptor assy	Adapter komplett	Assemblee d'adaptateur	Addatore-complessivo	Adaptador-conjunto	-
1700 0770	1	U2770436	Splitter module	Splitter-Modul	Module de relais	Commando riduttore	Modulo splitter	1
1700 0774	2	14197	"O" ring	"O" ring	Joint torique	"O" ring	Junta torique	2
1700 0776	3	MX-8-0826	Screw M8 x 30	Schraube M8 x 30	Vis M8 x 30	Vite M8 x 30	Tornillo M8 x 30	-
1700 0778 0010	1	2771947	Air regulator	Luftregler	Regulateur pneumatique	Regolatore aria	Regulator de aire	1
1700 0778 0020	1	X2771748	Elbow adaptor 1/8 NPT	Winkelverschraubung	Adaptateur-coude	Addatore-raccordo a gomita	Adaptador-tubo acodado	2
1700 0778 0030	1	12769	Nipple 1/8	-	-	-	-	-
1700 0780	1	4304602	Breather	Entluffer	Ranillard	Sfiatatoi	Respiro	-
1700 0782	-	71203	Silicone lube	Silikonenschmierung	Lubrifiant au silicone	Lubrificante di silicone	Silicona lubricante	-
1700 0785	0		Screw-stop M10 x 33.5	Schraube	Vis	Vite	Tornillo	-

Sequence No	Qty	Part No	English	Deutsch	Français	Italiano	Español	Stock Qty
1705	1	2770137	Gasket-SBH	Dichtung	Joint	Guarnizione	Junta	1
1706	2	MX-8-1069	Setscrew M10 x 45	Schraube	Vie	Vite	Tornillo	-
1707	16	MX-8-1068	Setscrew M10	Schraube	Vie	Vite	Tornillo	-
1710	2	20815	Lifting eye	Hebeose	Patte de levage	Anello di soleramento	Pieca de izar	-
1715	2	MX-8-1069	Screw M10 x 45	Schraube	Vie	Vite	Tornillo	-
1725	1	2771415	Gasket-Interlock	Dichtung	Joint	Guarnizione	Junta	1
1730	1	2771284	Cover	Deckel	Couvercle	Coperchio	Tapa	-
1731	2	MX-8-0801	Screw M8 x 14	Schraube	Vie	Vite	Tornillo	-
1732	2	MX-10-0801	Washer M8	Scheibe	Rondelle	Rondella	Arandela	-
1735	2	2771299	Switch pin	Stift-druckschalter	Goupille-contacteur	Alberino-interruttore	Pasador-Interruptor	-
1740	3	5588510	'O'ring	'O'ring	Joint torique	Guarnizione toroidale	Junta torica	3
1745	2	2771532	Reverse (bay) switch	Ruckfahrrechtschalter	Contacteur d'indicateur feu AR	Interruttore Indicatore retromarcia	Interruptor indicador luz MA	2
1746	1	2771842	Neutral switch	Neutralstellungschalter	Contacteur de point mort	Interruttore folle	Interruptor de punto muerto	1
1747	3	X2014116	Protective cap	Deckel	Couvercle	Coperchio	Tapa	3
1750	0		Plug-	Stopfen	Bouchon	Tappo	Tapon	-
1770	2	X2771361	Adaptor-straight 1/16 PTF	Adapter	Adaptateur	Adattore	Adaptador	-
1805	1	2771156	Gasket-control, (LRC/SBH)	Dichtung	Joint	Guarnizione	Junta	1
1807	-	X65127	LOCTITE 5203	LOCTITE 5203	LOCTITE 5203	LOCTITE 5203	LOCTITE 5203	-
1810	1	X11261	Stud M10 x 30	Stiftschraube	Goujon	Prigioniero	Esparago	-
1815	4	X11262	Conical nut M10	Mutter	Ecrou	Dado conico	Tuerca	4
1820	4	X11263	Locknut M10	Mutter	Contre-ecrou	Controdado	Tuerca dl cierre	-

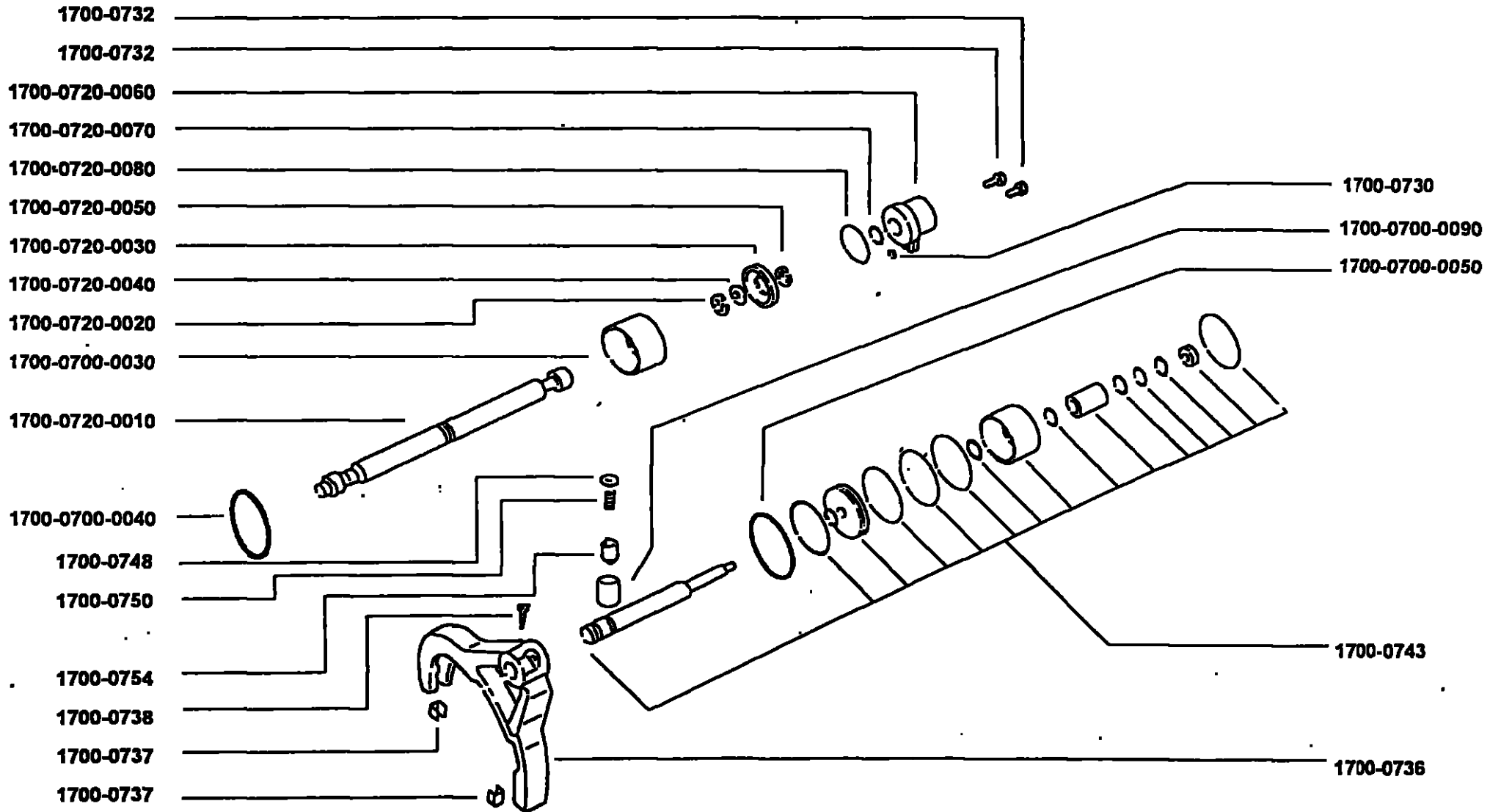

Range/Splitter Cylinders, Zylinder-schalt/splitter, Cylindres-de selection/de relais, Cilindros-cambio/riduttore, Cilindros-cambio gamas/splitter
Section 12b

Sequence No	Qty	Part No	English	Deutsch	Francais	Italiano	Español	Stock Qty
1700 0700 0030	1	2771123	Range sleeve	Bereichs-Hülse	Manchon de gamme	Manicotto comando selez gamma	Casquillo de gama	-
1700 0700 0035	-	X2772378	LOCTITE 63	LOCTITE 63	LOCTITE 63	LOCTITE 63	LOCTITE 63	-
1700 0700 0040	1	X2770203	Quadring	Quadring	Quadring	Anello	Quadring	2
1700 0700 0050	1	X2770089	Quadring	Quadring	Quadring	Anello	Quadring	2
1700 0700 0900	1	2771544	Sleeve-detent	Hülse arretier	Manchon	Manicotto	Casquillo	2
1700 0730	1	14187	"O" ring	"O" ring	Joint torique	"O" ring	Junta torique	2
1700 0732	2	X-8-1804M	Screw M8 x 30	Schraube	Vis	Vite	Tornillo	-
1700 0736	1	2770727	Splitter yoke	Spitter-Schaltgabel	Fourchette de relais	Forcella comando riduttore	Horquilla del splitter	-
1700 0737	2	2770139	Copper insert	Kupfereinlage	Insert ouivre	Inserto rame	Plaquita de cobre	2
1700 0738	1	2770919	Splitter screw	Spitter-Schraube	Vis de relais	Vite	Tornillo del splitter	-
1700 0743	1	U2771422	Splitter Cyl. assy.					1
1700 0748	1	2771418	Washer	Soehelbe	Rondelle	Rosetta	Arandella	1
1700 0750	1	4302134	Spring	Feder	Resort	Molla	Muelle	1
1700 0754	1	2771419	Plunger	Schieber	Plongeur	Nuttoloio	Vastago	1
1700 0720 0010	1	2770671	Range shift bar	Bereichs-Schaltstange	Barre du sélecteur de gamme	Asta selettoria gamma	Varilla de gama	-
1700 0720 0020	1	2771967	Circlip	Sicherungerring	Circlips	Anello elastico	Anillo elástico	2

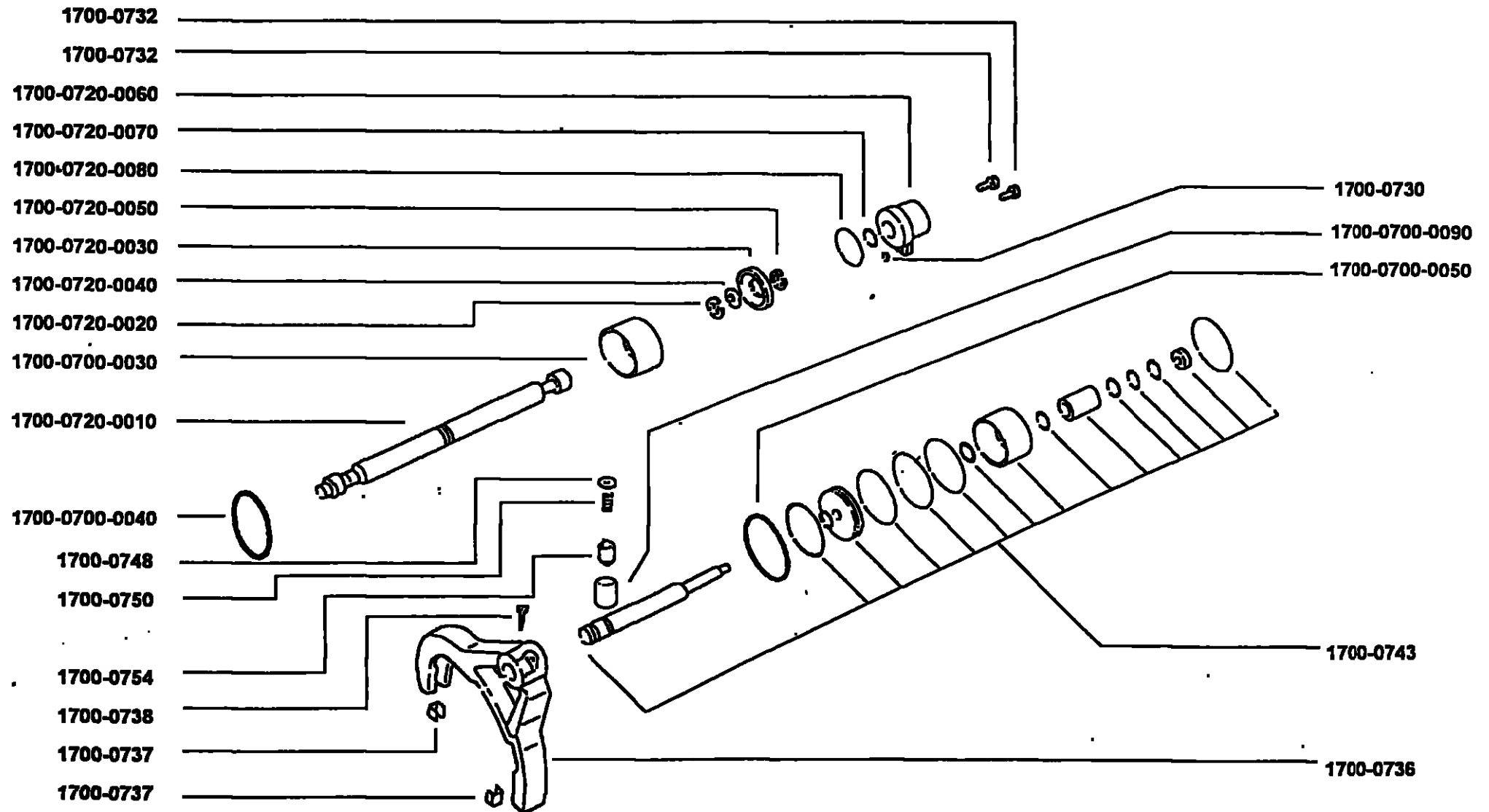

Sequence No	Qty	Part No	English	Deutsch	Français	Italiano	Español	Stock Qty
1700 0720 0030	1	2770089	Range piston	Bereichs-Kolben	Piston de gamme	Pistonolno comando selez gamma	Piston de gama	-
1700 0720 0040	1	X2770140	"O" ring	"O" ring	Joint torique	"O" ring	Junta tórica	2
1700 0720 0050	1	2771967	Circlip	Sicherungering	Circlips	Anello elastico	Anillo elástico	2
1700 0720 0060	1	2771087	Range cover	Bereichs-Deckel	Couvercle de gamme	Coperchio comando selez gamma	Tapa de la gama	-
1700 0720 0070	1	X2770203	Quedring	Quedring	Quedring	Anello	Quedring	2
1700 0720 0080	1	X2770078	"O" ring	"O" ring	Joint torique	"O" ring	Junta tórica	2

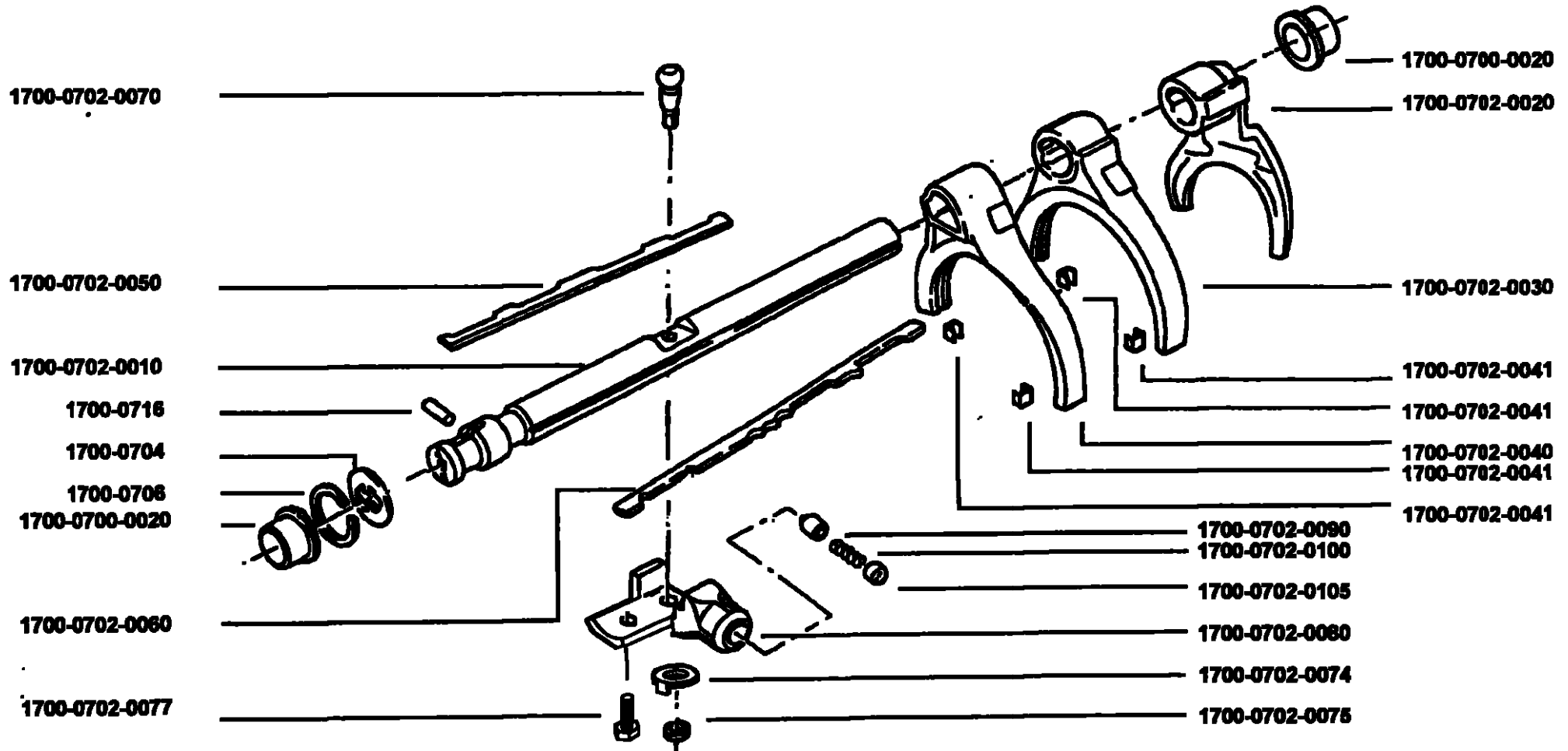

Sequence No	Qty	Part No	English	Deutsch	Français	Italiano	Español	Stock Qty
1700 0700 0020	2	2770085	Bush	Buchse	Bague	Boccola	Cesquillo	2
1700 0702 0010	1	2771284	Shift shaft	Schaltwelle	Axe du sélecteur	Asta selett. marcia	Varilla de cambios	-
1700 0702 0020	1	2770781	Yoke-reverse	Schaltgabel	Fourchette	Forcella	Horquilla	-
1700 0702 0030	1	2772010	Yoke 1st/2nd	Schaltgabel	Fourchette	Forcella	Horquilla	-
1700 0702 0040	1	2772011	Yoke 3rd/4th	Schaltgabel	Fourchette	Forcella	Horquilla	-
1700 0702 0041	4	2770138	Copper insert	Kupfereinlage	Insert cuivre	Inserto rame	Plaquita de cobre	2
1700 0702 0050	1	2771402	Shift key	Schaltklinke	Reglette du sélecteur	Chiavetta di comando	Chaveta de cambios	-
1700 0702 0060	1	2771416	Interlock key	Verrriegelungskleine	Reglette de verrouillage	Chiavetta di consenso Innesto	Chaveta de entrecierre	-
1700 0702 0070	1	2771075	Pin	Stift	Goupille	Spina	Pasador	-
1700 0702 0074	2	2771076	Tab washer	Scheibe	Rondelle	Rosetta	Arandella	1
1700 0702 0075	1	MX-8-1001	Nut	Mutter	Ecrou	Dado	Tuerca	-
1700 0702 0077	1	MX-8-1014	Screw M10 x 25	Schraube	Vis	Vite	Tornillo	-
1700 0702 0080	1	2771170	Spring	Feder	Ressort	Molla	Muelle	1
1700 0702 0090	1	2771283	Shift block	Schaltblock	Verrou	Blochetto	Bloque de cambio	-
1700 0702 0100	1	2770868	Plunger detent	Schieber	Plongeur	Nottolino	Vástago	-
1700 0702 0105	1	2770880	Plug-detent	Stopfen-schieber	Bouchon-plongeur	Tappo-nottolino	Tapón-vástago	-
1700 0702 0110	-	X10915	LOCTITE 270	LOCTITE 270	LOCTITE 270	LOCTITE 270	LOCTITE 270	-
1700 0704	1	2771417	Actuating plate	Platte-	Plaque-	Piastra-	Placa-	-
1700 0706	1	4302183	Snap ring	Sicherungsring	Cirolips	Anello di sicurezza	Anillo elastico	-
1700 0716	1	2770084	Interlock pin	Verrriegelungsstift	Goupille de verrouillage	Spina di consenso	Pasador de cierre	-

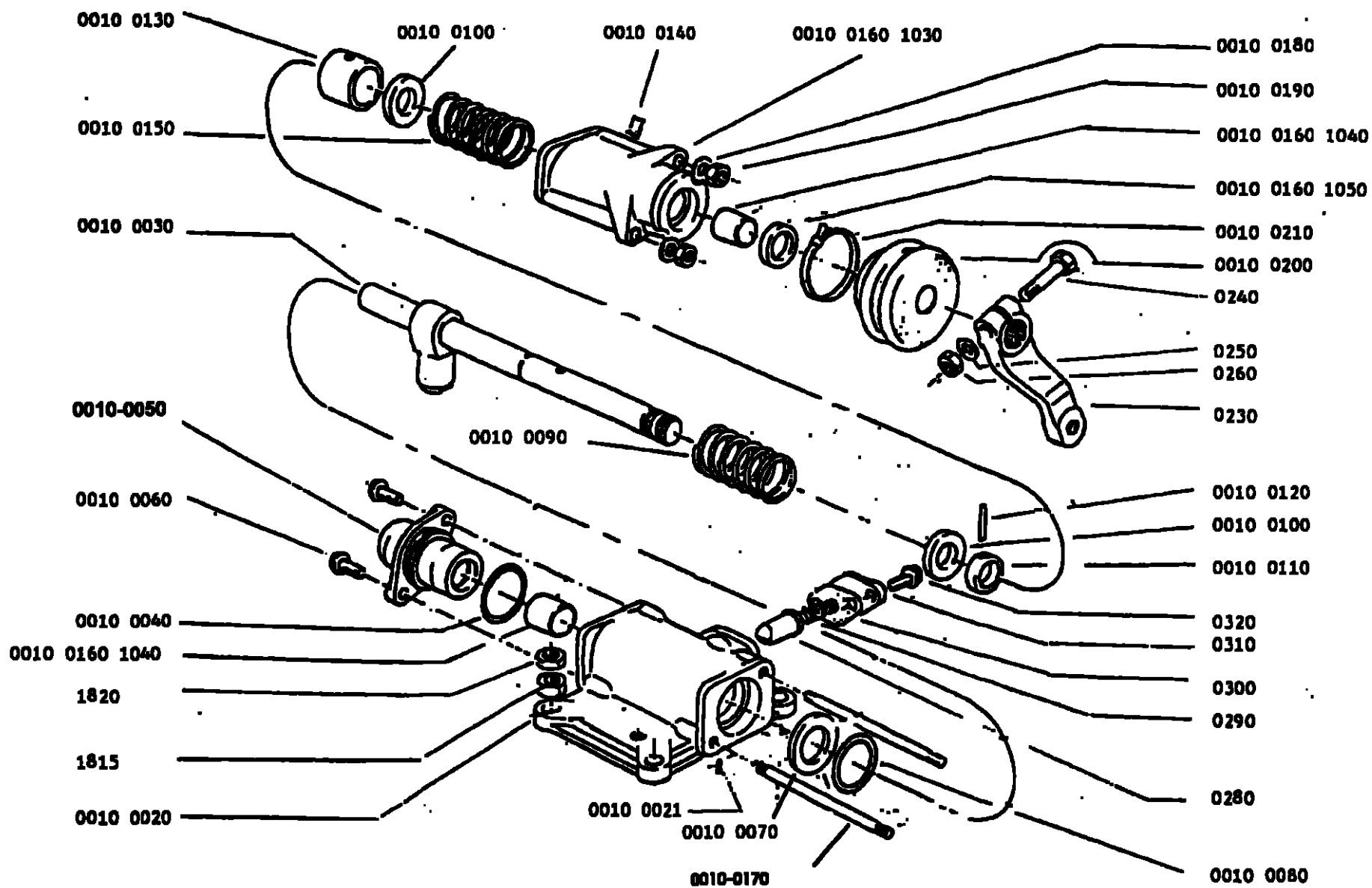

Section 13

Remote Control Assembly, Fernschaltung, Commande à Distance, Complessivo Comando a distanza, Conjunto Control Remoto Section 13

Sequence No	Qty	Part No	English	Deutsch	Français	Italiano	Español	Stock Qty
1800 0010	Ref	U2771002	LRC assy-RH	-	-	-	-	-
1800 0010 0020	1	2770821	Centre housing	Gehäuse	Carter central	Corpo centrale	Alojamiento central	-
1800 0010 0021	1	2770905	Screw M5 x 11.5	Schraube	Vis	Vite	Tornillo	-
1800 0010 0022	1	X2771195	Scrawlock/seal	Schraube/ dicht	Vis/joint	Vite/tenuta	Tornillo/retén	1
1800 0010 0030	1	U2771194	Cross shaft assy	Welle komplett	Assemblée d'axe	Albero-complessivo	Eje-conjunto	-
1800 0010 0050	1	U2771129	Bearing housing assy	Lager gehäuse- komplett	Corps, roulement- assemblee	Scatola, cuscinetto- complessivo	Ervuelta, cojinete- conjunto	-
1800 0010 0080	2	MX-8-0825	Screw	Schraube	Vis	Vite	Tornillo	-
1800 0010 0070	1	2770843	Retaining washer	Scheibe	Rondelle de retenue	Rondella di fermo	Arandela retén	-
1800 0010 0080	1	X2770847	"O" ring	"O" ring	Joint torque	"O" ring	Junta tórica	1
1800 0010 0090	1	F99791	Spring	Feder	Ressort	Molla	Muelle	1
1800 0010 0100	1	F91154	Stopwasher	Anschlagsscheibe	Rondelle d'arrêt	Rondella di fermo	Arandela tope	-
1800 0010 0110	1	F91138	Collar	Scheibe	Collier	Collare	Collar	-
1800 0010 0120	1	F91141	Pin	Stift	Goupille	Spina	Pasador	-
1800 0010 0130	1	2770832	Spacer X-gate	Distanzscheibe-	Entretoise-	Anello distanziale-	Espaciador-	-
1800 0010 0140	1	MX-11-0602	Screw	Schraube	Vis	Vite	Tornillo	-
1800 0010 0141	-	X2771951	LOCTITE 572	LOCTITE 572	LOCTITE 572	LOCTITE 572	LOCTITE 572	-
1800 0010 0150	1	F91138	Spring	Feder	Ressort	Molla	Muelle	1
1800 0010 0160 1030	1	ZU2771031	Outer housing assy	Gehäuse komplett	Carter extérieur- assemblee	Corpo esterno- complessivo	Cubierta externa- conjunto	-
1800 0010 0160 1040	1	15313	Bush	Buchse	Bague	Boccola	Casquillo	2

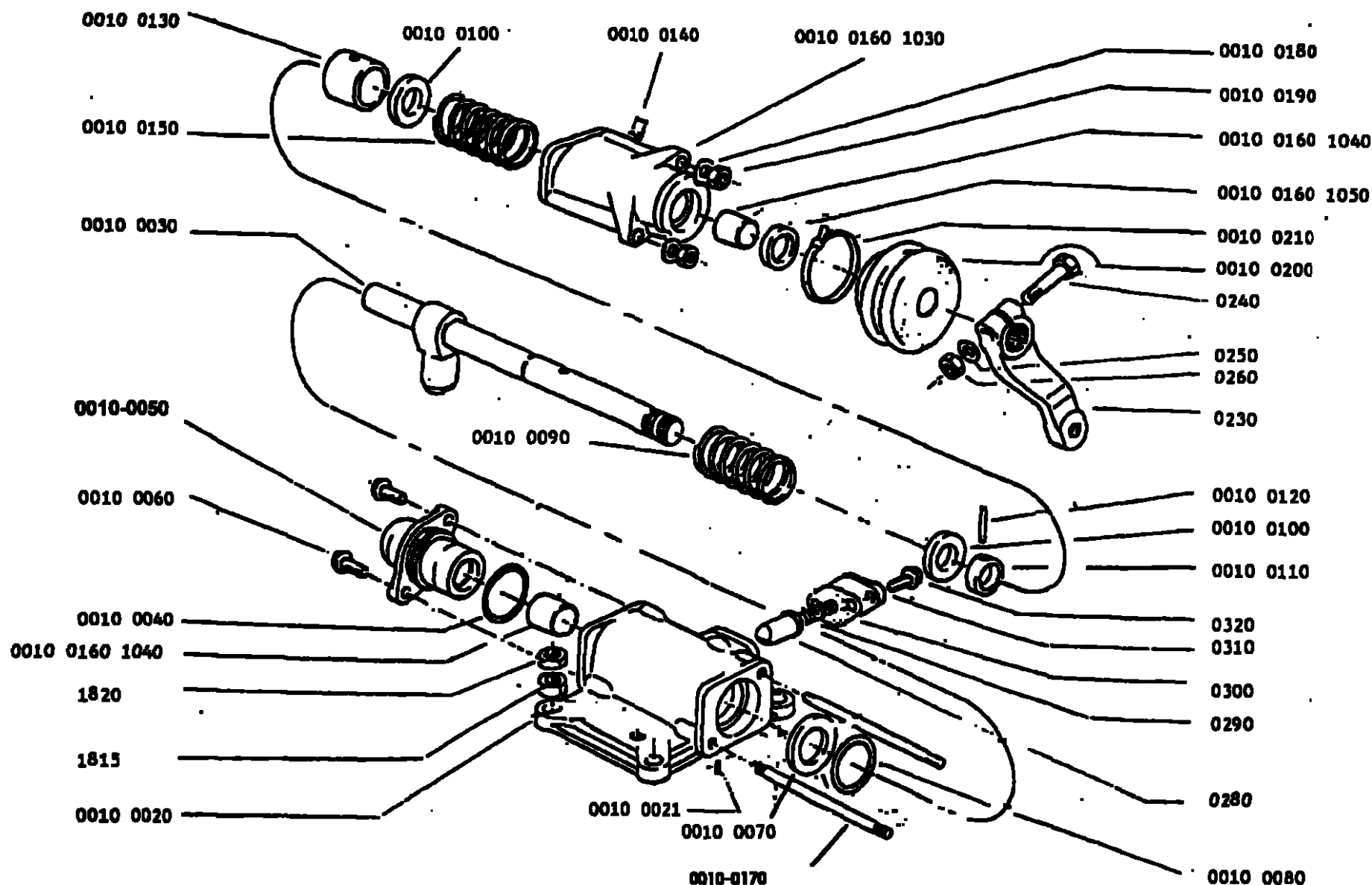

Section 13

Sequence No	Qty	Part No	English	Deutsch	Français	Italiano	Español	Stock Qty
1800 0010 0180 1050	1	F98181	Oil seal	Öldichtung	Joint d'étanchéité	Guarnizione Olio	Reten del aceite	-
1800 0010 0180 1080	1	2770823	Outer housing	Gehäuse komplett	Carter extérieur- assemblee	Corpo esterno- complessivo	Cubierta externa- conjunto	-
1800 0010 0170	2	2770858	Stud M8 x 141	Stiftschraube	Goujon	Prigioniero	Espárrago	-
1800 0010 0171	-	X2771951	LOCTITE 572	LOCTITE 572	LOCTITE 572	LOCTITE 572	LOCTITE 572	-
1800 0010 0180	2	MX-10-0801	Washer M8	Scheibe	Rondelle	Rondella	Arandela	-
1800 0010 0190	2	MX-9-0802	Nut M8	Mutter	Ecrou	Dado	Tuerca	-
1800 0010 0200	1	14975	Boot	Faltenbalg	Soufflet de protection	Soffietto	Manillar de caucho	-
1800 0010 0210	1	F98430	Cable tie	Kabelklammer	Collier attache-câble	Fascetta	Sujetacable	-
1800 0230	1	F91180	Outer lever	Hebel	Levier extérieur	Lava esterna	Manubrio exterior	-
1800 0240	1	MX-8-1007	Bolt M10 x 50	Schraube	Boulon	Bullone	Perno	-
1800 0250	1	MX-3-1001	Lockwasher M10	Federring	Rondelle grower	Rondella di sicurezza	Arandela de cierre	-
1800 0260	1	MX-9-1001	Nut M10	Mutter	Ecrou	Dado	Tuerca	-
1800 0280	1	2772824	Plunger - detent	Schieber	Plongeur	Nottolino	Vastago	-
1800 0290	1	8876679	Spring-rov.	Feder	Ressort	Molla	Muelle	-
1800 0300	1	2770830	Gasket-detent cover	Dichtung	Joint	Guarnizione	Junta	1
1800 0310	1	2770829	Detent cover	Deckel	Couvercle de verrouillage	Coperohietto	Tapa retén	-
1800 0320	2	MX-8-0825	Bolt M8 x 25	Schraube	Boulon	Bullone	Perno	-

SERVICE KIT
DATE: 4/95

T20519 Bearing Kit-Single Front Countershaft; Lager Kit vorolere Vorgelegewelle.

Section 14

Qty	Part No.	English	Deutsch	Francais	Italiano	Espaniol
2	X2770467	Bearing, Front Countershaft	Lager	Roulement	Cuscinetto	Cojinete
1	K-2805	Shim Kit RTS	Distanzring	Entretoise	Distanziale	Separador

SERVICE KIT
DATE: 4/95

T20520 Bearing Kit-RTS; Lager kit RTS.

Qty	Part No.	English	Deutsch	Francais	Italiano	Espaniol
2	X2770094	Bearing; Reverse Idler	Lager	Roulement	Cuscinetto	Cojinete
4	X2770467	Bearing; Front Countershaft	Lager	Roulement	Cuscinetto	Cojinete
4	21343	Bearing; Rear Countershaft	Lager	Roulement	Cuscinetto	Cojinete
1	K-2805	Shim Kit-RTS	Distanzring	Entretoise	Distanziale	Separador
1	5566503	Bearing; Input Shaft	Lager	Roulement	Cuscinetto	Cojinete
1	E-1025-173	Thrust Washer	Stuetzscheibe	Rondelle de pousse	Rondella di spinta	Arandela de empuje
1	5556503	Bearing; Output Shaft	Lager	Roulement	Cuscinetto	Cojinete
2	2770760	Thrust Bearing Splitter	Stuetzscheibe	Rondelle de pousse	Rondella di spinta	Arandela de empuje
1	2770774	Thrust Bearing Splitter	Stuetzscheibe	Rondelle de pousse	Rondella di spinta	Arandela de empuje

SERVICE KIT
DATE: 4/95

T20523 Bearing Kit-Single Rear Countershaft; Lager Kit-hintere Vorgelegewelle

Qty	Part No.	English	Deutsch	Français	Italiano	Espanol
2	21343	Bearing, Rear Countershaft	Lager	Roulement	Cuscinetto	Cojinete
1	K-2805	Shim Kit RTS	Distanzring	Entretoise	Distanziale	Separador

SERVICE KIT
DATE: 4/95

T20524 Seal Kit-RTS: Dichtring Kit RTS

Qty	Part No.	English	Deutsch	Français	Italiano	Espanol
1	2770218	Seal; Input Shaft	Dichtring-Eingang	Joint d'étancheite	Guarnizione tenuta	Reten
1	2770491	Seal; Output Shaft	Dichtring-Ausgang	Joint d'étancheite	Guarnizione tenuta	Reten
1	F96181	Seal; Control	Dichtring-Schaltung	Joint d'étancheite	Guarnizione tenuta	Reten

SERVICE KIT
DATE: 10/95

T20547 Range Module Kit- 16 Spd H; Gruppenventil Kit-RTS

Qty	Part No.	English	Deutsch	Francais	Itallano	Espaniol
1	A-6342	Range Module	Gruppenventil			
2	14197	O Ring	O Ring	Joint Torique	Guaranizione Toroidale	Junta torica
1	15569	O Ring	O Ring	Joint Torique	Guaranizione Toroidale	Junta torica
3	MX-8-0835	Screw	Schraube	Vis	Vite	Tornillo
1	MX-8-0825	Screw	Schraube	Vis	Vite	Tornillo

SERVICE KIT
DATE: 5/95

T20518 S-Series Spltr Kit

Qty	Part No.	English	Deutsch	Francais	Itallano	Espaniol
1	U2770435	Splitter Module	Splitter Ventil			
2	14197	O-Ring	O-Ring	Joint Torique	Guaranizione Toroidale	Junta torica
4	MX-8-0825	Screw	Schraube	Vis	Vite	Tornillo

SERVICE KIT
DATE: 10/95

T20522 1st/2nd Synchro Kit-RTS
1/2 Synchroniseur assemble
1/2 Conjunto sincronizador

1/2 Synchron Kit komplett.
1/2 Complessivo sincronizzatore.

Qty	Part No.	English	Deutsch	Francals	Italiano	Espaniol
1	U2770651	1/2 Synchro	Synchronisierung	Synchroniseur	Complessivo	Sincronizador
3	2770200	Spring	Feder	Ressort	Molla	Muelle
3	2770113	Plunger	Schieber	Plonger	Nottolino	Vastago
3	2770665	Retainer	Riegel	Clavette	Tassello	Retenedor

SERVICE KIT
DATE: 4/95

T20515 3rd/4th Synchro Kit-RTS
3/4 Synchroniseur assemble
3/4 Conjunto sincronizador

3/4 Synchron Kit komplett.
3/4 Complessivo sincronizzatore.

Qty	Part No.	English	Deutsch	Francals	Italiano	Espaniol
1	U2770884	3/4 Synchro	Synchronisierung	Synchroniseur	Complessivo	Sincronizador
3	2770200	Spring	Feder	Ressort	Molla	Muelle
3	2770113	Plunger	Schieber	Plonger	Nottolino	Vastago
3	2770276	Retainer	Riegel	Clavette	Tassello	Retendor

SERVICE KIT . T20516 Splltter Synchro Kit-RTSO: Synchron Kit Splltter-RTSO**DATE: 12/95**

Qty	Part No.	English	Deutsch	Francals	Itallano	Espaniol
1	U2771681	Synchro Assy	Synchronring	Synchro	Sinconizzatore	Sincronizador
3	277119	Spring	Feder	Ressort	Molla	Muella
3	2770673	Pin-Guide spring				
1	2771687	Splitter Clutch Plate	Platte	Plaque	Piastra	Placa
1	U2771680	Synchro Assy	Synchronring	Synchro	Sinconizzatore	Sincronizador

SERVICE KIT T20521 Range Synchro Kit-RTS: Synchron Kit Gruppe RTS**DATE: 11/95**

Qty	Part No.	English	Deutsch	Francals	Itallano	Espaniol
1	U2771411	Range Rdn Synchro	Synohronring-U	Synchro	Sinconizzatore	Sincronizador
3	14897	Spring	Feder	Ressort	Molla	Muella
1	2771330	Range Clutch Plate	Platte	Plaque	Piastra	Placa
1	U2771329	Range Drct Synchro	Synchronring-D	Synchro	Sinconizzatore	Sincronizador
1	2771808	Range Direct Clutch	Kupplung direkt			
1	2770655	Range Rdn Plate	Kupplung-U			
3	2770281	Range Retainer	Riegel	Clavette	Tassello	Retenedor

SERVICE KIT**T20524 Seal Kit-RTS: Dichtring Kit-RTS**

DATE: 4/95

Qty	Part No.	English	Deutsch	Francais	Italiano	Espanol
1	2770218	Seal; Input Shaft	Dichtring Eingang	Joint d etancheite	Guarnizione tenuta	Reten
1	2770491	Seal; Output Shaft	Dichtring Ausgang	Joint d etancheite	Guarnizione tenuta	Reten
1	F96181	Seal; Control	Dichtring Schaltung	Joint d etancheite	Guarnizione tenuta	Reten

SERVICE KIT**K-2805 Shim Kit-RTS: Distanzring Kit-RTS**

DATE: 4/95

Qty	Part No.	English	Deutsch	Francais	Italiano	Espanol
1	21452	Shim	Distanzring	Entretoise	Distanziale	Separador
1	21453	Shim	Distanzring	Entretoise	Distanziale	Separador
1	21454	Shim	Distanzring	Entretoise	Distanziale	Separador
1	21455	Shim	Distanzring	Entretoise	Distanziale	Separador
1	21456	Shim	Distanzring	Entretoise	Distanziale	Separador
1	21457	Shim	Distanzring	Entretoise	Distanziale	Separador
1	21458	Shim	Distanzring	Entretoise	Distanziale	Separador
1	21459	Shim	Distanzring	Entretoise	Distanziale	Separador
1	21460	Shim	Distanzring	Entretoise	Distanziale	Separador
1	21461	Shim	Distanzring	Entretoise	Distanziale	Separador
1	21684	Shim	Distanzring	Entretoise	Distanziale	Separador
1	21685	Shim	Distanzring	Entretoise	Distanziale	Separador

SERVICE KIT**T20525 Gasket Kit-RTS: Dichtung Kit-RTS****DATE: 5/95**

Qty	Part No.	English	Deutsch	Francals	Itallano	Espaniol
1	1684	Gasket; 6 bolt PTO	Dichtung	Joint	Guarnizione	Junta
1	4302810	Gasket; 8 bolt PTO	Dichtung	Joint	Guarnizione	Junta
1	2770944	Gasket; oil pump cover	Dichtung	Joint	Guarnizione	Junta
1	2770968	Gasket; Clutch Housing	Dichtung	Joint	Guarnizione	Junta
2	17179	Gasket; Switch	Dichtung	Joint	Guarnizione	Junta
2	15900	Gasket; Switch	Dichtung	Joint	Guarnizione	Junta
1	2770945	Gasket; Rear Housing	Dichtung	Joint	Guarnizione	Junta
1	2770878	Gasket; Speedo Housing	Dichtung	Joint	Guarnizione	Junta
2	4302246	Gasket; Rear Bearing Cover	Dichtung	Joint	Guarnizione	Junta
2	2770346	Gasket; P.T.O.cover	Dichtung	Joint	Guarnizione	Junta
1	2770137	Gasket; Shift Bar Housing	Dichtung	Joint	Guarnizione	Junta
1	2771156	Gasket; Control	Dichtung	Joint	Guarnizione	Junta
1	2770830	Gasket; Control Detent	Dichtung	Joint	Guarnizione	Junta