

**HEAVY DUTY
SYNCHROMESH TRANSMISSIONS**

**Y2771141
RTSO 12316A**

Illustrated Parts List

Ersatzteilliste

Catalogue Rechange

Catalogo Ricambi

Catálogo de Piezas de Recambio

12/95

Section	English	Deutsch	Français	Italiano	Español	Section
1 a	Maincase assy	Gehäuse Hauptgetriebe	Ensemble carter principal	Scatola principale	Conjunto carcasa principal	1
1 b	Lubrication System					1b
2	Input shaft	Antriebswelle	Arbre d'entrée	Albero di entrata	Eje primario	2
3	Mainshaft	Hauptwelle	Arbre principal assemblé	Albero principale completo	Conjunto eje principal	3
4	Countershaft assy	Vorgelegewellen	Arbre secondaire	Contralbero completo	Conjunto eje secundario	4
5	Reverse Idler	Rückwärtsgang-Umkehrad	Pignon de renvoi marche AR	Ingranaggio rinvio RM	Conjunto inversor MA	5
6	Auxiliary housing	Hinteres gehäuse	Carter auxiliaire	Scatola posteriore	Tapa trasera	6
7	Auxiliary Gearing	Nachschaltgruppe	Engrenage auxiliaire	Scatola ausiliaria	Sección auxiliar	7
12 a	Shift bar housing	Schaltdeckel	Convercle de changement de vitesse	Coperchio selettore	Tapa de varillas	12a
12 b	Range Cylinder	Zylinder-schalt	Cylindre de selection	Cilindro-Cambio	Cilindro-cambio gamas	12b
12 c	Selector Mechanism	Schalt	Selection	Cambio	Cambio	12c
	Stocking quantity shows recommended quantities for 25 transmissions	Lagerempfehlung für 25 Getriebe	Quantite de stockage pour 25 unites	Quantità per 25 cambi	Cant stock para 25 caja de cambio	

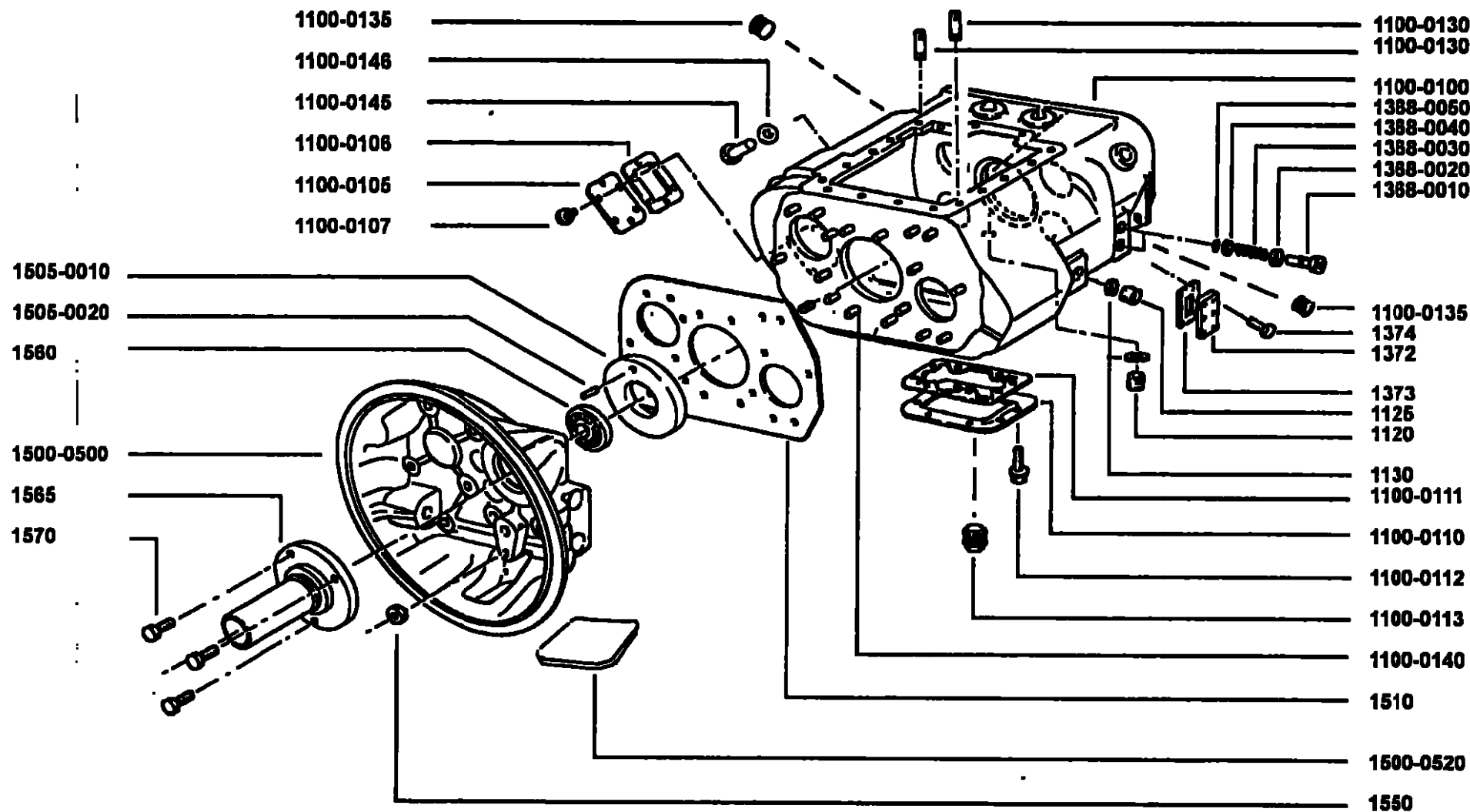

Section 1

Maincase assembly, Gehäuse Hauptgetriebe, Ensemble carter principal, Scatola principale, Conjunto carcasa principal

Section 1a

Sequence No Sequenz Nr Séquence No Sequela No Secuencia No	Qty Anzahl Qte Qta No.	Part No Teile Nr Piece No Rif No.Cat	English	Deutsch	Français	Italiano	Español	Stock Qty Lager Empf Qte de stockage Quantità Cant Stock
1100 0100	1	2771364	Maincase	Getriebegehäuse	Carter principal	Scatola principale	Carcasa principal	-
1100 0105	1	2005144	Cover	Deckel	Couvercle	Coperchio	Tapa	-
1100 0106	1	1684 (120525)	Gasket 6 bolt PTO	Dichtung	Joint	Guarnizione	Junta	2
1100 0107	6	MX-8-1031	Screw M10 x 30	Schraube	Vis	Vite	Tornillo	-
1100 0110	1	U14082	Cover 8 Bolt PTO	Deckel	Couvercle	Coperchio	Tapa	-
1100 0111	1	4302810 (120525)	Gasket 8 bolt PTO	Dichtung	Joint	Guarnizione	Junta	2
1100 0112	8	MX-8-1235	Screw M12 x 35	Schraube	Vis	Vite	Tornillo	-
1100 0113	1	X14166	Drain Plug Magnetic	Olablass-Schraube	Bouchon aimante	Tappo	Tapon	1
1100 0130	2	2770245	Dowel	Stift	Goupille	Spina	Passador	-
1100 0135	2	X2013517	Plug 1/8	Stopfen	Bouchon	Tappo	Tapon	-
1100 0140	18	2770351	Stud	Stiftschraube	Goujon	Prigioniero	Espárrago	-
1100 0145	1	118876353	Oil Strainer Assy	Ol-Ablassschraube	Crepine	Filtro	Filtro	1
1100 0146	1	X8875280	Washer					1
1120	1	X8875853	Plug Magnetic drain	Verschlusschraube	Bouchon	Tappo	Tap	-
1125	1	X8875854	Plug Filler	Verschlusschraube	Bouchon	Tappo	Tapón	-
1130	2	X8875238	Washer	Scheibeg	Rondelle	Rondella	Arandela	2
1368 0010	2	2770939	Plug	Schraube	Bouchon	Tappo	Tap	2
1368 0020	2	8875855	Washer	Scheibe	Rondelle	Rondella	Arandela	-
1368 0030	2	2770940	Spring	Feder	Ressort	Molla	Muelle	1
1368 0040	2	2770941	Compression ring	Scheibe	Rondelle	Rondella	Arandela	-

Main Case Assembly, Gehäuse Hauptgetriebe, Ensemble Carter Principal, Scatola Principale, Conjunto Carcasa Principal S- Series

s-01/1-02

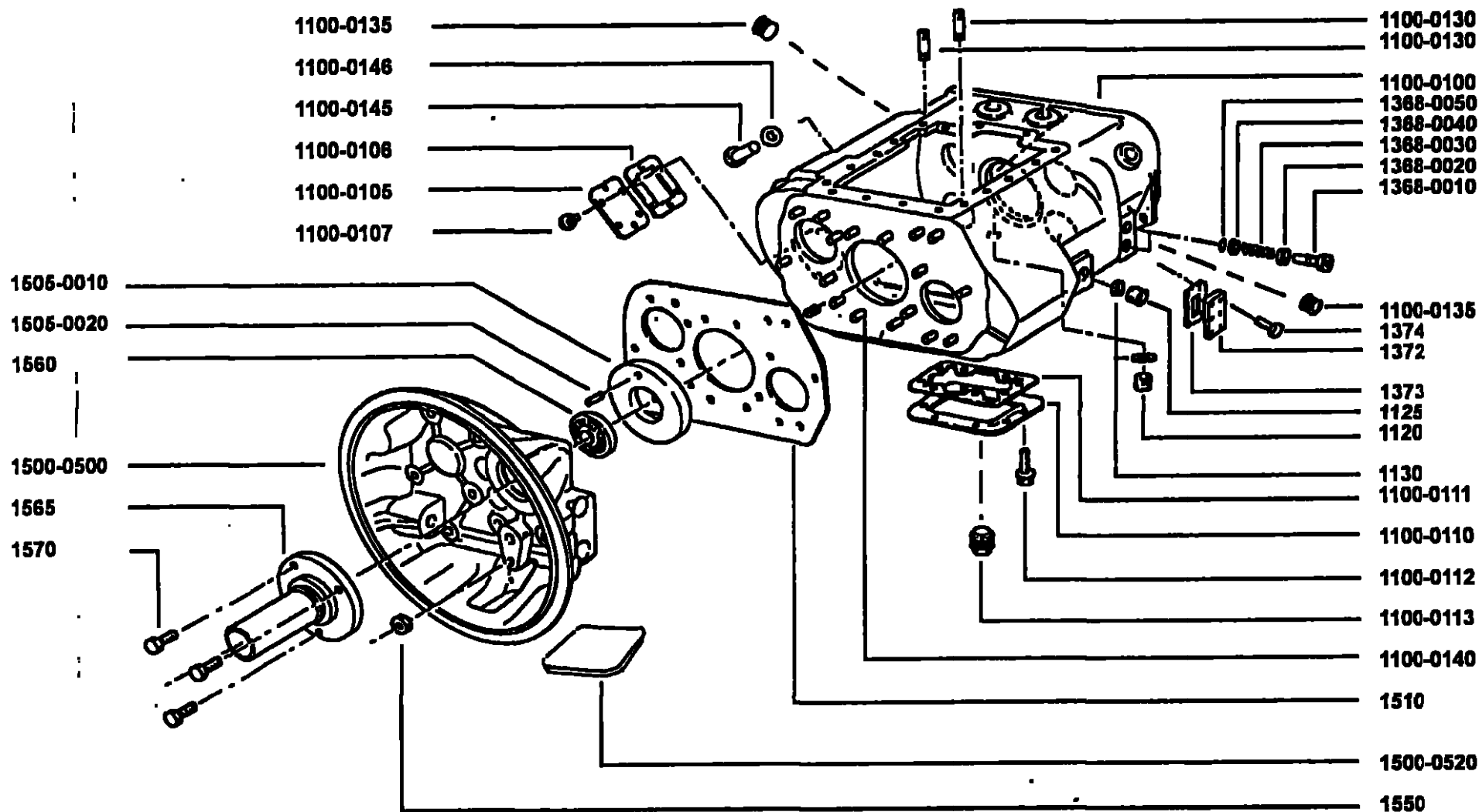

Section 1

Sequence No Sequenz Nr Séquence No Sequela No Secuencia No	Qty Anzahl Qte Qtu No.	Part No Telle Nr Piece No Rif No.Cat	English	Deutsch	Français	Italiano	Español	Stock Qty Lager Empf Qte de stockage Quantità Cant Stock
1368 0050	2	2770942	"O" ring	"O" ring	Joint torique	"O" ring	Junta tórica	2
1372	1	2770943	Transfer plate	Transferplatte	Plaque de transfert	Piastrina	Placa de transferencia	-
1373	1	2770944 (120525)	Gasket	Dichtung	Joint	Guarnizione	Junta	2
1374	6	MX-8-0621	Screw M6 x 30	Schraube	Vis	Vite	Tornillo	-
1500 0500	1	2771441	Clutch Housing SAE 1	Kupplungsgehäuse	Cloche d'embrayage	Campana	Tapa del embrague	-
1500 0520	1	2770149	Inspection Cover					-
1505 0010	1	2770101	Oil Distribution Plate	Ölverteilungsblech	Plaque de répartition d'huile	Disco diffusore	Placa	-
1505 0020	1	X8870542	Dowel	Stift	Goupille	Spina	Pasador	2
1510	1	2770968 (120525)	Gasket Clutch Housing	Dichtung	Joint	Guarnizione	Junta	2
1550	18	MX-9-1204	Nut M12	Mutter	Ecrou	Dado	Tuerca	-
1560	1	2770218 (120524)	Seal Input Shaft	Dichtung	Joint	Guarnizione	Sallaje/Reten	2
1565	1	2770096	Cover Input Shaft	Deckel	Convercle	Coperchio	Tapa	-
1570	3	MX-8- 0825	Bolt M8 x 25	Schraube	Vis	Vite	Tornillo	-

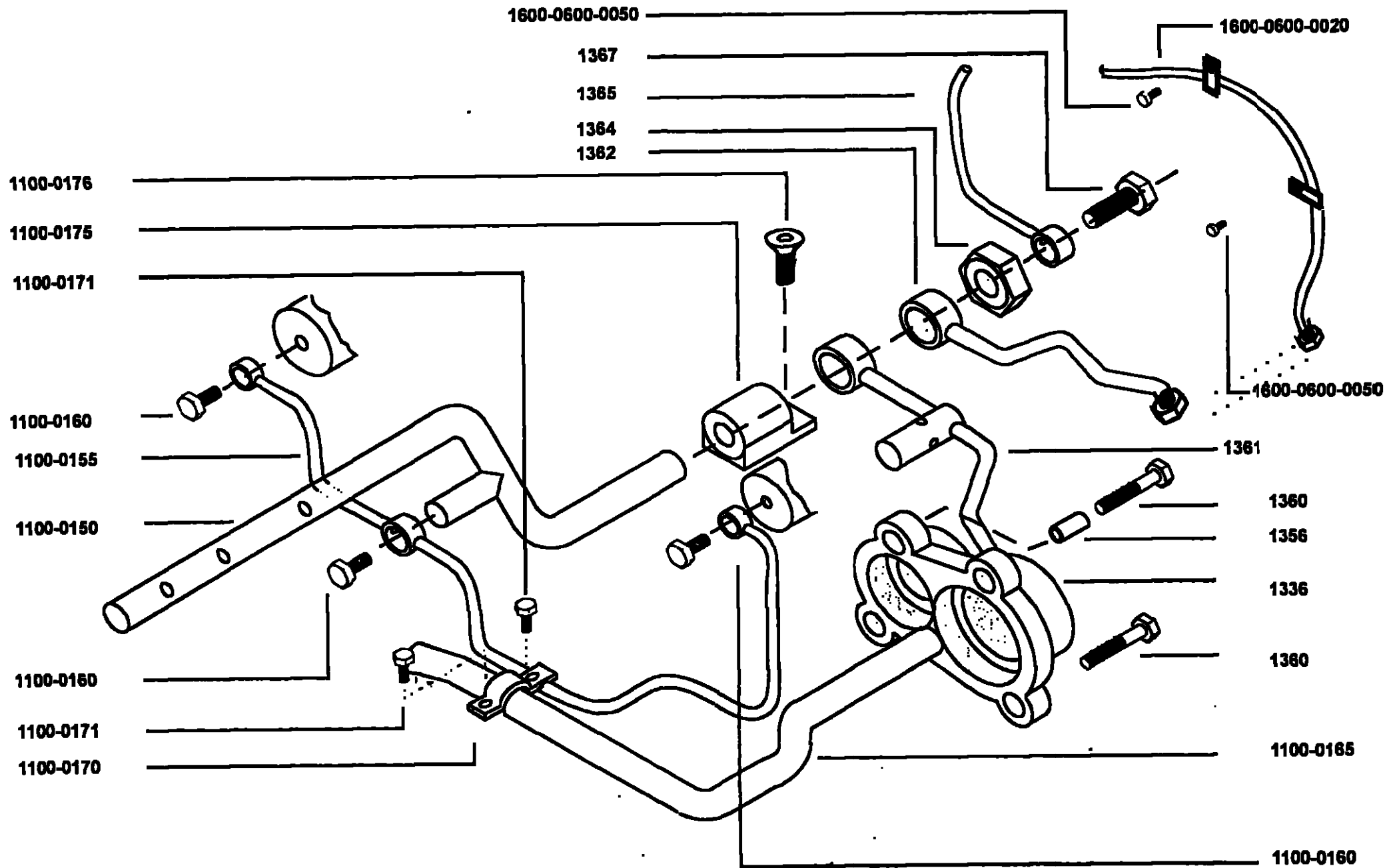

Section 1b

Lubrication System

Section 1b

Sequence No	Qty	Part No	English	Deutsch	Français	Italiano	Español	Stock Qty
1100 0150	1	2771252	Bar-Spray					
1100 0155	1	2771255	Pipe-Supply R Idlr					-
1100 0160	3	2771259	Bolt-Banjo	Schraube	Boulon	Bullone	Perno	-
1100 0165	1	2771254	Pipe Suction Pump					-
1100 0170	1	2771260	Clip					
1100 0171	2	MX-8-0605	Screw M6 x 16	Schraube	Boulon	Bullone	Perno	-
1100 0175	1	2771251	Manifold					
1100 0176	1	MX-8-0626	Screw M6 x 20	Schraube	Boulon	Bullone	Perno	-
1336	1	U2771390	Oil Pump Assy					
1356	1	4300649	Roll Pin					
1360	2	MX-8-1028	Screw M10 X 40	Schraube	Boulon	Bullone	Perno	-
1361	1	U2771253	Supply Pipe Rel V					
1362	1	2771256	Pipe Supply PTO Lower					
1364	1	2771258	Connectr Pipe/Manifold					
1365	1	2771257	Pipe Supply PTO Upper					
1367	1	2771259	Bolt Banjo	Schraube	Boulon	Bullone	Perno	-
1600 0600 0020	1	U2771465	Tube Assy - Output Bearing					
1600 0600 0050	2	X-13-209	Bolt	Schraube	Boulon	Bullone	Perno	-

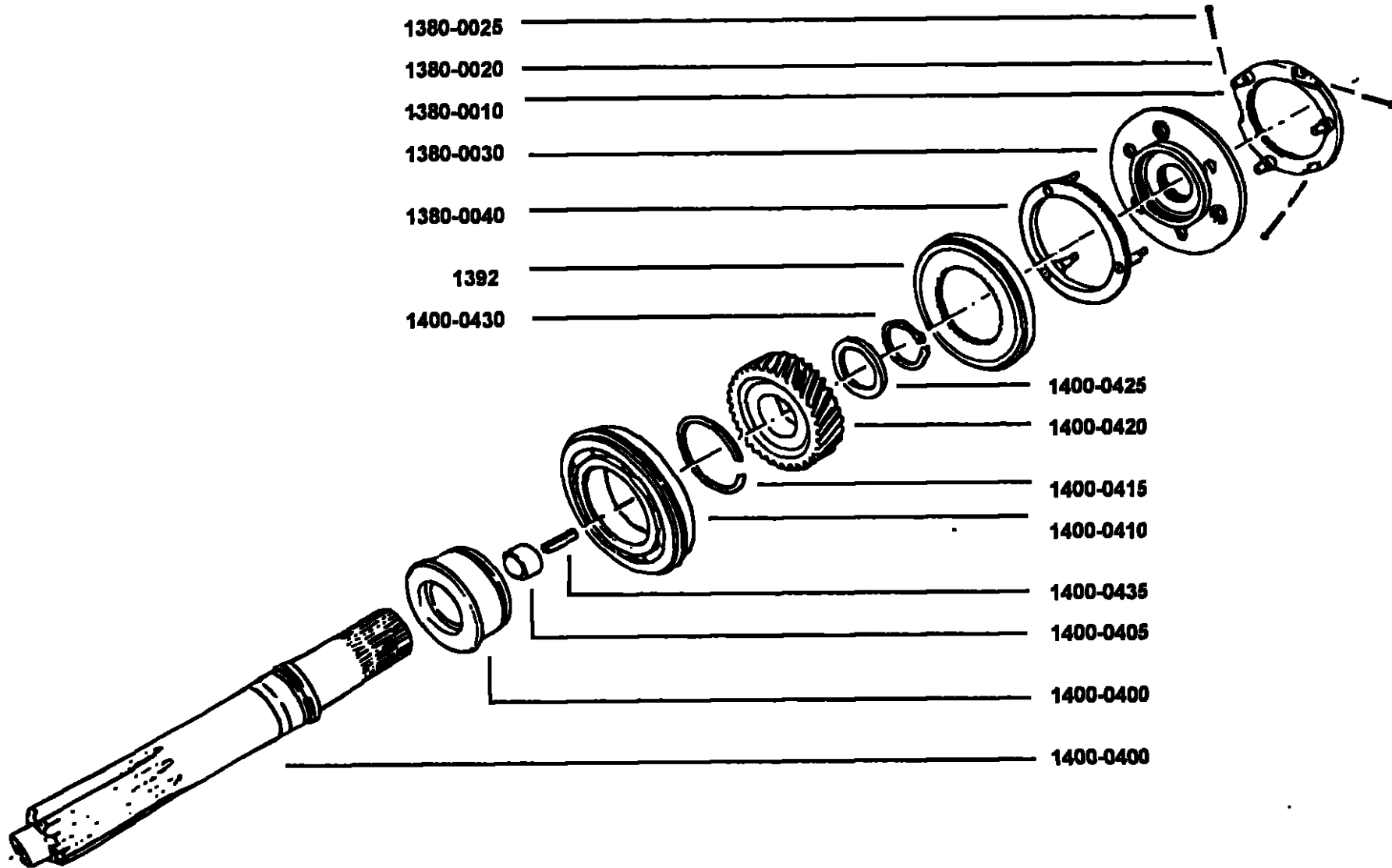

Input shaft, Antriebswelle, Arbre d'entrée, Albero di entrata, Eje primario

Section 2

Sequence No	Qty	Part No	English	Deutsch	Français	Italiano	Español	Stock Qty
1400	Ref.	U2771764	Input shaft assy.					-
1400 0400	1	U2771154	Input shaft and spacer	Antriebswelle	Arbre d'entrée	Albero di entrata	Eje primario	-
1400 0405	1	2770291	Bush	Buchse	Bague	Boccola	Casquillo	1
1400 0410	1	5566503 (120520)	Bearing	Lager	Roulement	Cuscinetto	Cojinete	2
1400 0415	1	16722	Snap ring	Sicherungsring	Circlips	Anello elastico	Anillo elástico	2
1400 0420	1	2771743	Splitter gear	Zahnrad	Pignon	Ingranaggio	Engranaje	
1400 0425	1	2771151	Splitter gear sleeve					
1400 0430	1	X2771224	Circlip	Sicherungsring	Circlips	Anello elastico	Anillo elástico	2
1400 0435	1	2770416	Oil tube	Ölleitung	Tube d'huile	Tubetto olio	Tubería para el aceite	-
1380 0010	1	U2771681 (120516)	Splitter direct cone/pin assembly	Splitterkegel mit Stiften Direktgang	Cône/goupille directe de relais	Cono sincronizzatore riduttore	Conjunto directo cono/pasador del splitter	-
1380 0020	3	2770119 (120516)	Spring	Feder	Ressort	Molla	Muelle	3
1380 0025	3	2770673 (120516)	Pin-Guide Spring					
1380 0030	1	2771687 (120516)	Splitter clutch plate	Splitter-Kupplungsplatte	Plateau d'embrayage de relais	Disco innesto riduttore	Placa del embrague splitter	-
1380 0040	1	U2771680 (120516)	Splitter cone/pin assy	Splitterkegel mit Stiften	Cône/goupille de relais	Anello sincronizzatore riduttore	Conj. cono/pasador del splitter	-
1392	1	2771695	Synchroniser cup	Synchronglocke	Coupelle de synchro	Cono sincronizzatore	Anillo del sincronizador	-

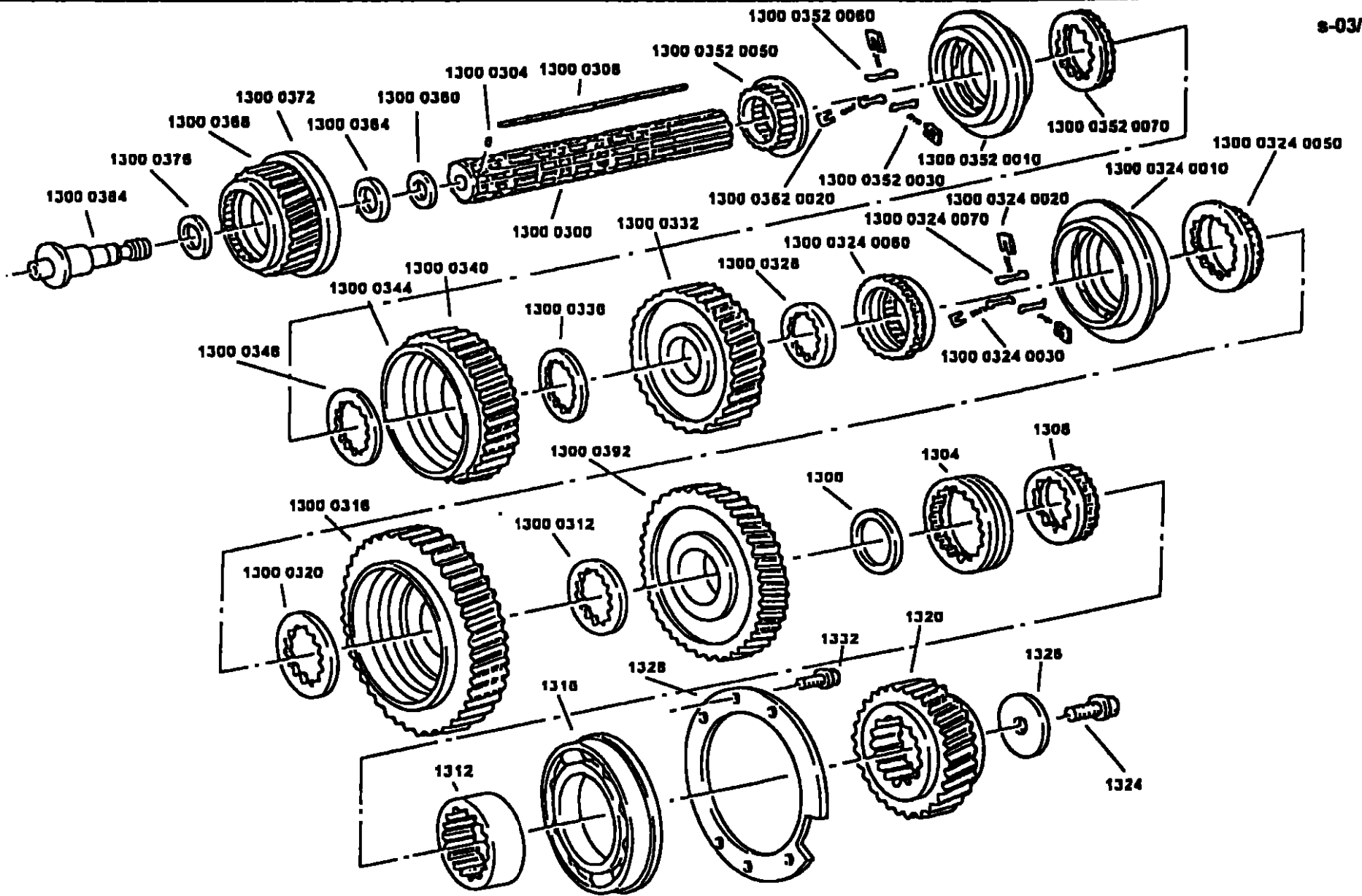

Mainshaft, Hauptwelle, Arbre principal assemblé, Albero principale completo, Conjunto eje principal

Section 3

Sequence No	Qty	Part No	English	Deutsch	Français	Italiano	Español	Stock Qty
1300	Ref.	U2771209	Mainshaft assy					-
1300 0300	1	2771583	Mainshaft	Hauptwelle	Arbre principal	Albero principale	Ije principal	-
1300 0304	1	62504	Pin	Stift	Goupille	Spina	Pasador	-
1300 0308	1	2771460	Key Mainshaft	Keil	Reglette	Chiavetta	Chaveta	-
1300 0312	1	2770783	Mainshaft thrust washer	Hauptwellen - Druckscheibe	Rondelle de poussée d'arbre principal	Rondella di spallamento albero principale	Arandela de empaje del eje principal	1
1300 0316	1	2770261	1st gear	1.-Gangrad	Pignon de 1ère	Ingranaggio 1°vel	Engranaje 1°	-
1300 0320	1	2770783	Mainshaft thrust washer	Hauptwellen - Druckscheibe	Rondelle de poussée d'arbre principal	Rondella di spallamento albero principale	Arandela de empaje del eje principal	1
1300 0324 0010	1	U2770651 (120522)	1/2 gear synchro assy	Syncronsatz 1./2. Gang	Synchro de 1ère et 2ème	Compl. sincronizzatore 1/2 vel	Conj. sincronización de 1°/2°	1
1300 0324 0020	3	2770113 (120522)	Pre-Energising plunger	Schieber	Plongeur	Nottlino	Vastago	3
1300 0324 0030	3	2770200 (120522)	Spring	Feder	Ressort	Molla	Muelle	1
1300 0324 0050	1	2770663	1/2 gear sliding clutch	Schiebemuffe 1./2. Gang	C'rabot de 1ère et 2ème	Manicotto scorrevole 1/2 vel	Carrete de 1°/2°	1
1300 0324 0060	1	2770664	Sliding clutch	Schiebemuffe	C'rabot	Manicotto scorrevole	Carrete	1
1300 0324 0070	3	2770665 (120522)	Retainer	Riegel	Clavette de crabot	L'assello	Retenedor	-
1300 0328	1	2770783	Mainshaft thrust washer	Hauptwellen - Druckscheibe	Rondelle de poussée d'arbre principal	Rondella di spallamento albero principale	Arandela de empaje del eje principal	1
1300 0332	1	2771098	2nd gear	2. Gangrad	Pignon 2ème	Ingranaggio 2° velocità	Engranaje 2°	-
1300 0336	1	2770783	Mainshaft thrust washer	Hauptwellen - Druckscheibe	Rondelle de poussée d'arbre principal	Rondella di spallamento albero principale	Arandela de empaje del eje principal	-
1300 0340	1	2770263	3rd gear	3. Gangrad	Pignon 3ème	Ingranaggio 3° velocità	Engranaje 3°	-

Hauptwelle, Arbre Principal, Complesivo Albero Principale, Conjunto del Eje Principal

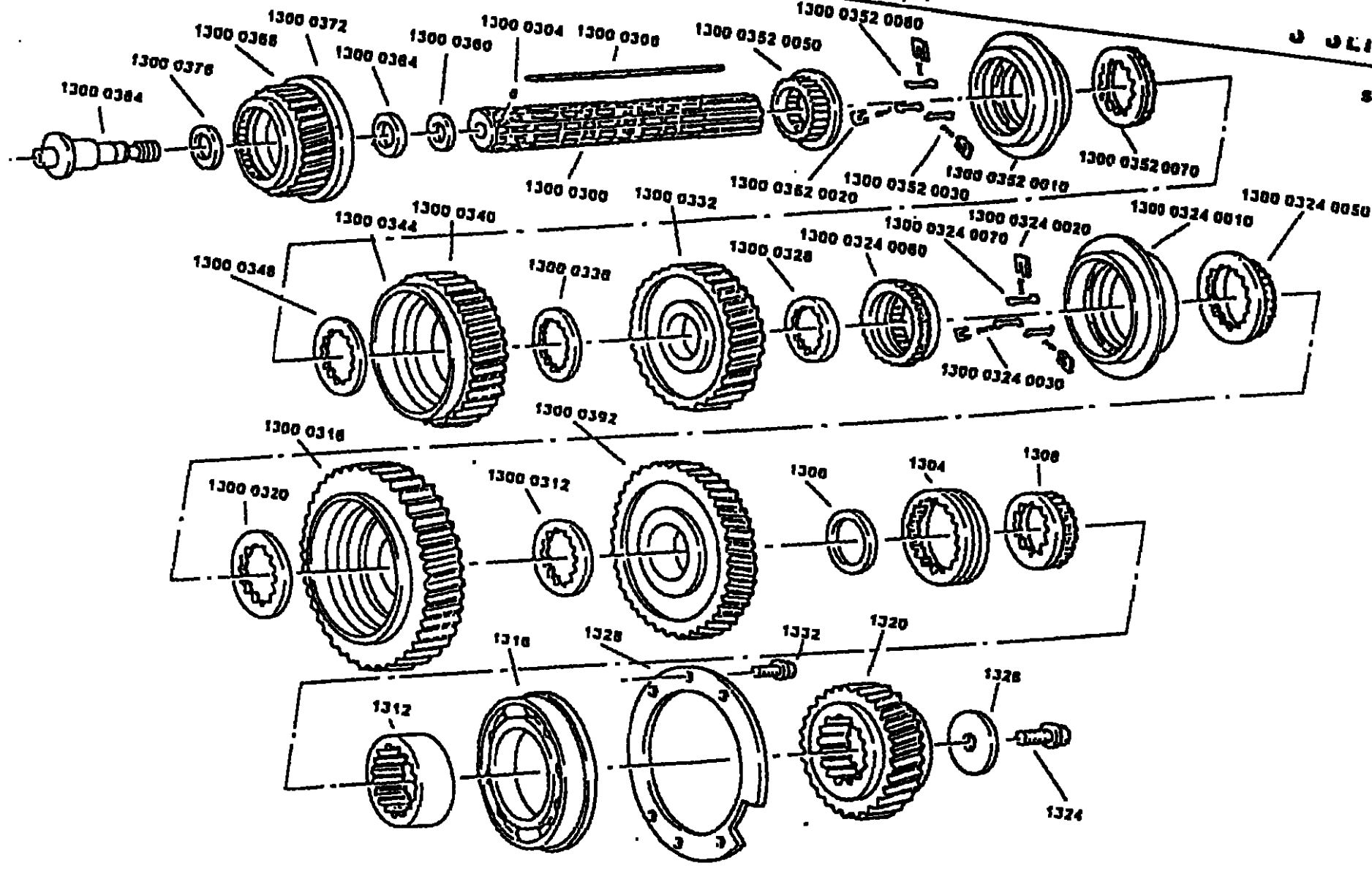

Sequence No	Qty	Part No	English	Deutsch	Français	Italiano	Español	Stock Qty
1300 0344	1	2771401	Synchroniser cup	Kupplungsstück	Coupelle de synchro	Cono sincronizzatore	Anillo del sincronizador	1
1300 0348	1	2770783	Mainshaft thrust washer	Hauptwellen - Druckscheibe	Rondelle de poussée d'arbre principal	Rondella di spallamento albero principale	Arandela de empuje del eje principal	1
1300 0352 0010	1	U2770884 (120515)	3/4 gear synchro assy	Syncronsatz 3/4. Gang	Synchro de 3ème/4ème	Compl. sincronizzatore 3/4 vel	Conj. sincronización de 3'/4'	1
1300 0352 0020	3	2770113 (120515)	Plunger	Holzen	Plongeur	Nottolino	Vástago	3
1300 0352 0030	3	2770200 (120515)	Spring	Feder	Ressort	Molla	Muelle	3
1300 0352 0050	1	2770748	3/4 gear sliding clutch	Schiebemuffe 3/4. Gang	Crabot de 3ème et 4ème	Manicotto sincronizzatore 3/4	Carrete de 3'/4'	1
1300 0352 0060	3	2770276 (120515)	Retainer	Riegel	Clavette de crabot	Fermo	Retenedor	-
1300 0352 0070	1	2770748	3/4 gear sliding clutch	Schiebemuffe 3/4. Gang	Crabot de 3ème et 4ème	Manicotto sincronizzatore 3/4	Carrete de 3'/4'	1
1300 0360	1	2770774 (120520)	Thrust washer	Druckscheibe	Rondelle de poussée	Rondella di spallamento	Arandela de empuje	1
1300 0364	1	X2770760 (120520)	Thrust bearing	Drucklager	Palier axial	Cuscinetto reggispianta	Conjuncte de empuje	1
1300 0368	1	2771673	4th gear	4. Gangrad	Pignon 4ème	Ingranaggio 4' velocità	Engranaje 4'	-
1300 0372	1	2771401	Synchroniser cup	Kupplungsstück	Coupelle de synchro	Cono sincronizzatore	Anillo del sincronizador	1
1300 0376	1	X2770760 (120520)	Thrust bearing	Drucklager	Palier axial	Cuscinetto reggispianta	Conjuncte de empuje	1
1300 0384	1	2771405	Mainshaft spindle	Hauptwellenspiendle	Broche d'arbre principal	Perno filettato	Busillo del eje principal	-
1300 0392	1	2771684	Reverse gear	RW.-Gangrad	Pignonde marche AR	Ingranaggio retromarcia	Engranaje MA	-
1304	1	2770442	Reverse sliding clutch	Schiebemuffe RW.-Gang	Crabot de marche AR	Manicotto retromarcia	Carrete MA	-

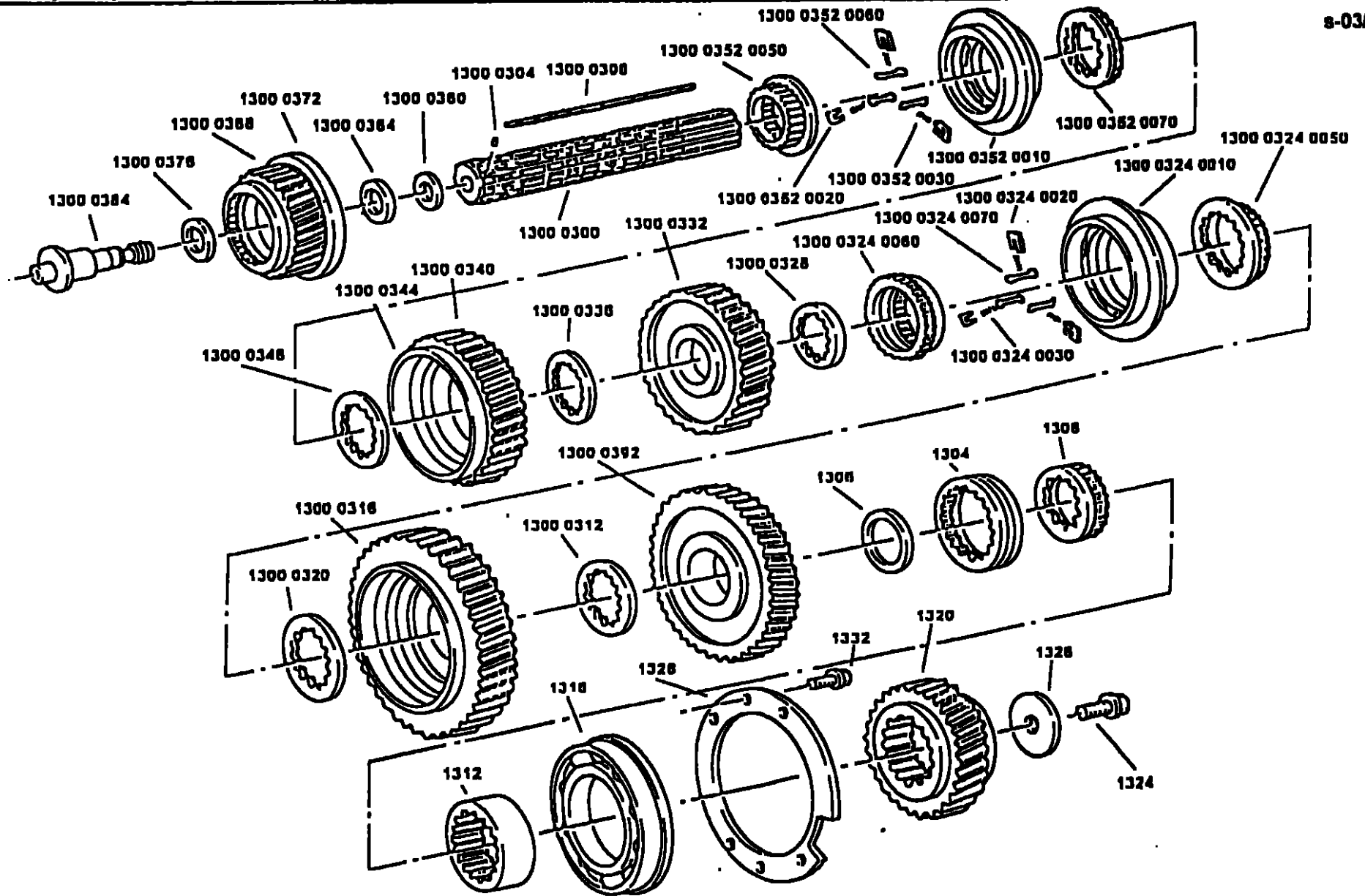

Sequence No	Qty	Part No	English	Deutsch	Francals	Italiano	Español	Stock Qty
1306	1	2770247	Thrust washer	Distanzring	Entretoise	Distanziale	Separador	-
1308	1	2771622	Reverse hub	RW.-Gang-Nabe	Moyeu de marche AR	Mozzo retromarcia	Cubo o campana MA	-
1312	1	2770265	Bearing spacer	Lagerdstanzring	Entretoise de roulement	Distanziale cuscinetto	Conjuncte separador	-
1316	1	5566503	Bearing	Lager	Roulement	Cuscinetto	Cojinete	2
1320	1	2770269	Mainshaft auxiliary drive gear	Antriebsrad Nachschaltgruppe	Pignon de transmission auxiliaire d'arbre principal	Ingranaggio conduttore ausiliario albero principale	Engranaje de accionamiento auxiliar del eje principal	-
1324	1	MX-7-1608	Screw M16 x 45	Schraube	Vis	Vite	Tornillo	-
1326	1	2770006	Retainer plate	Haltscheibe	Rondelle de retenue	Disco di fermo	Placa retenedora	-
1328	1	2770836	Bearing retainer	Lager-Haltplatte	Entretoise de roulement	Portacuscinetto	Retenedor del conjuncte	-
1332	6	MX-8-1061	Screw M10 x 30	Schraube	Vis	Vite	Tornillo	-

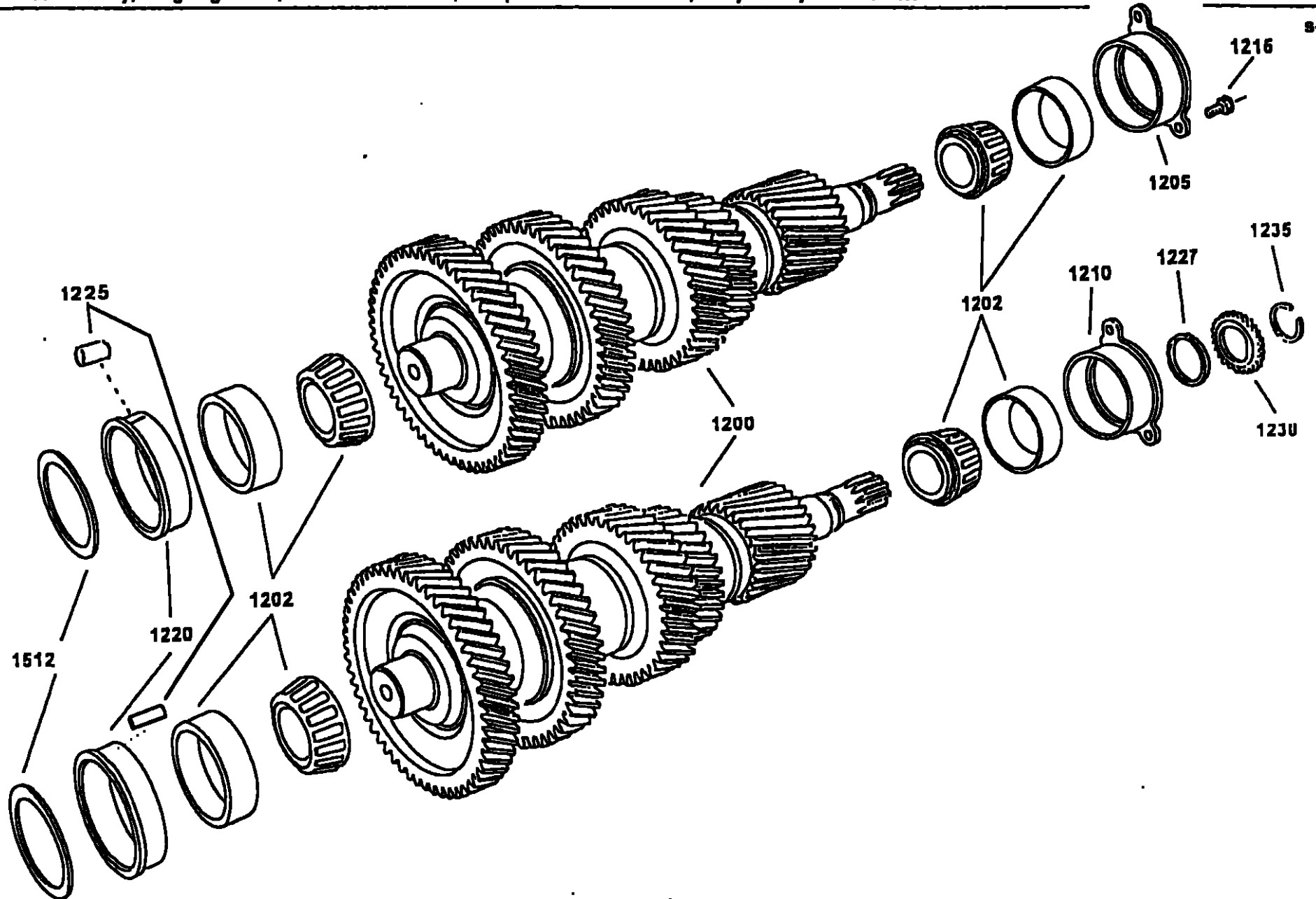

Countershaft assemblies, Vorgelegewellen, Arbre secondaire, Contralbero completo, Conjunto eje secundario

Section 4

Sequence No	Qty	Part No	English	Deutsch	Francais	Italiano	Español	Stock Qty
1200	2	U2770921	Countershaft assy	Vorgelegewellen	Arbre secondaire	Compl. contralbero	Conjunto eje secundario	-
1202	4	X2770467 (120519) (120520)	Bearing	Lager	Roulement	Cuscinetto	Cojinete	2
1205	1	2770311	Rear upper bearing retainer	Hinterer oberer Lagerhalter	Bague de retenue de roulement superieur AR	Portacuscinetto posteriore superiore	Retenedor del cojinete superior trasero	-
1210	1	2770644	Rear lower bearing retainer	Hinterer unterer Lagerhalter	Bague de retenue de roulement inferieur AR	Portacuscinetto posteriore inferiore	Retenedor del cojinete inferior trasero	-
1215	6	MX-8-1061	Screw M10 x 30	Schraube	Vis	Vite	Tornillo	-
1220	2	2770312	Front bearing sleeve	Hülse des vorderen Lagers	Anneau de roulement AV	Portacuscinetto anteriore	Casquillo del cojinete delantero	-
1225	1	X2770313	Roller					
1227	1	2770340	Spacer	Distanzscheibe	Entretoise	Distanziale	Separador	-
1230	1	13-1025-571	Gear: Pump drive	Pumpenantriebsrad	Pignon de pompe	Pignone; pompa	Engranaje de bomba	-
1235	1	4302082	Snap ring	Sicherungsring	Cirelips	Anello elastico	Anillo elástico	2
1512	2	K-2805	Shim Kit	Distanzring	Entretoise	Anello di registro	Separador	2

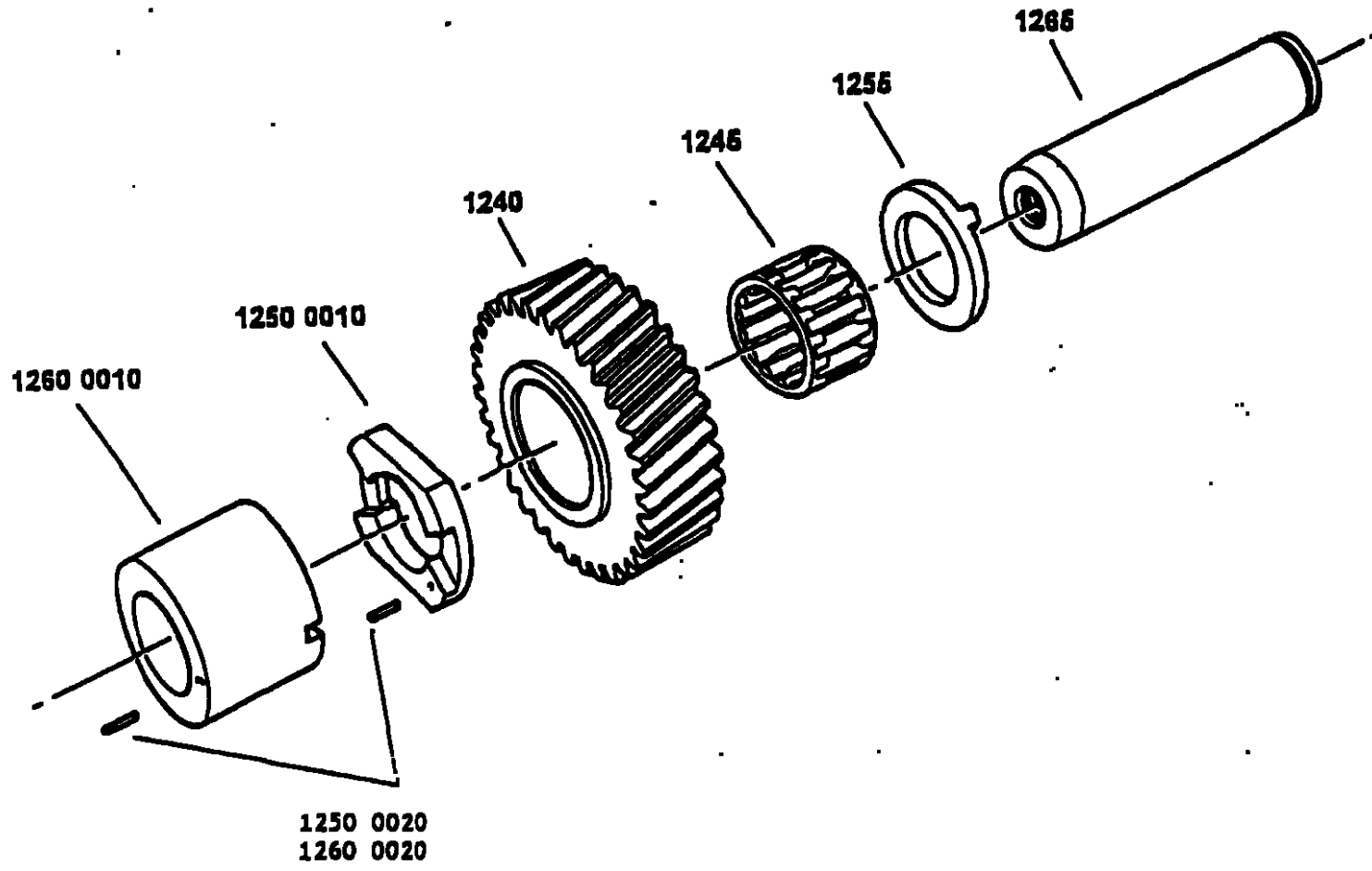

Reverse Idler, Rückwärtsgang-Umkehrad, pignon de renvoi marche AR, Ingranaggio rinvio RM, Conjunto Inversor MA

Section 5

Sequence No	Qty	Part No	English	Deutsch	Français	Italiano	Español	Stock Qty
1240	2	2770027	Gear	Zahnrad	Pignon	Ingranaggio	Engranaje	-
1245	2	X2770094 (120520)	Bearing	Lager	Roulement	Cuscinetto	Cojinete	2
1250 0010	2	2770024	Thrust washer	Anlaufscheibe	Rondelle de poussée	Rondella di spallamento	Arandela de empuje	1
1250 0020	2	62504	Pin	Stift	Goupille	Spina	Pasador	-
1255	2	2770025	Thrust washer	Anlaufscheibe	Rondelle de poussée	Rondella di spallamento	Arandela de empuje	1
1260 0010	2	2770317	Spacer	Distanzhülse	Entretoise	Distanziale	Separador	-
1260 0020	2	62504	Pin	Stift	Goupille	Spina	Pasador	-
1265	2	2770732	Reverse Idler shaft	Achse Rückwärtsgang- Umkehrad	Arbre de pignon de renvoi de marche AR	Alberino rinvio RM	Eje interno marcha atras	-

Rear Case Assembly, Nachschaltgruppen-Gehäuse, Carter Arriere Assemble, Comlessivo Scatola posteriore, Conjunto Tapa Trasera

s-06/1-03

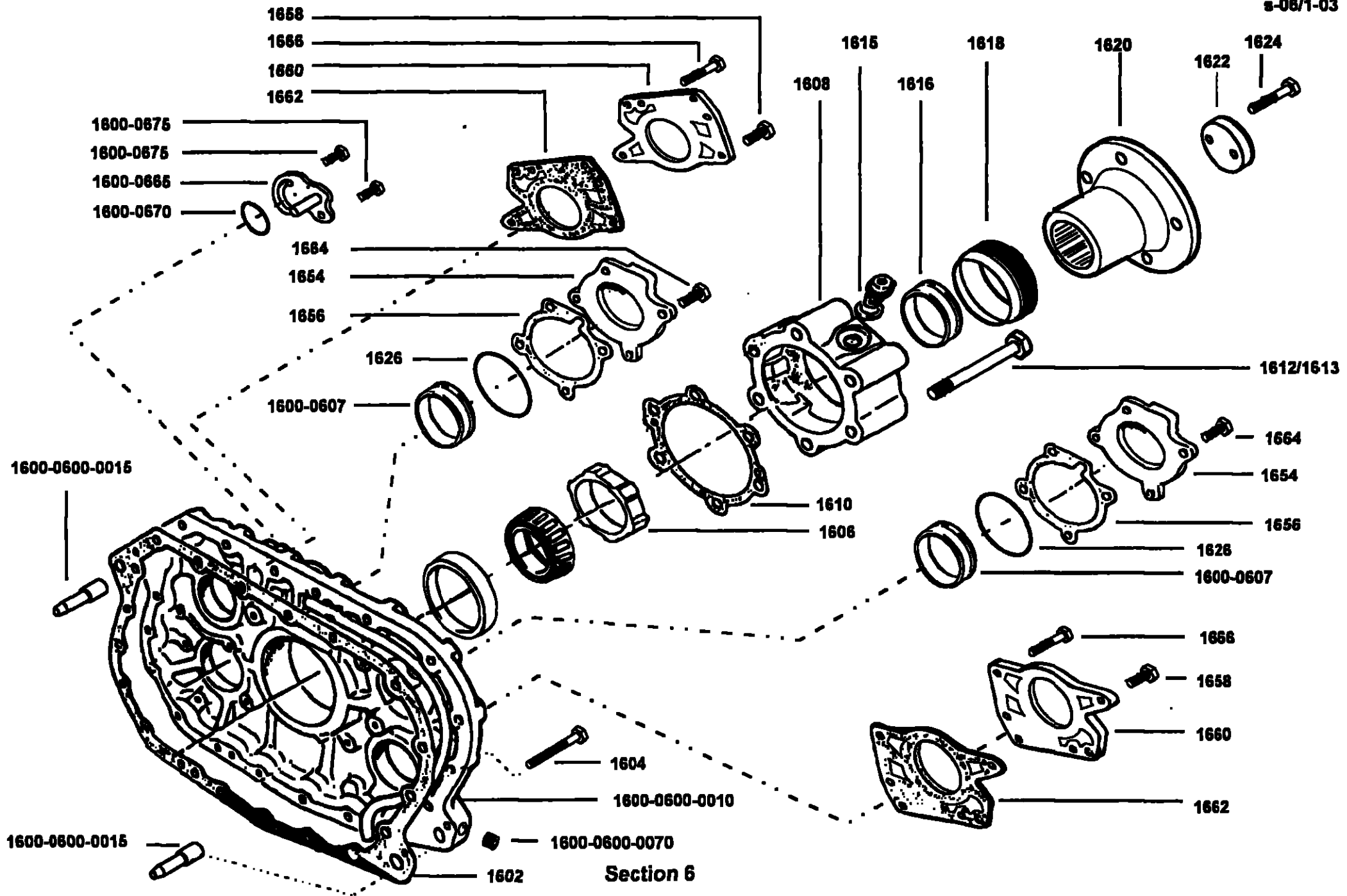

Sequence No	Qty	Part No	English	Deutsch	Francus	Italiano	Español	Stock Qty
1600	Ref.	U2771213	Rear case assy					-
1600 0600	Ref.	U2770966	Rear cover & pipe assy	Gehäuse Nachschaltgruppe mit Leitungen	Couvercle AR et tuyau	Coperchio posteriore e tubazioni	Conjunto tapa trasera y tubo	-
1600 0600 0010	1	2770864	Housing rear case	Hinteres gehäuse	Carter auxiliaire	Scatola posteriore	Tapa trasera	-
1600 0600 0015	2	2771029	Dowel	Passstift	Goupille	Grano	Espiga	2
1600 0600 0070	1	X2013517	Plug M6	Stopfen	Bouchon	Tappo	Tapon	-
1600 0665	1	AE-1025-023	Yoke bar cover	Schaltstangendeckel	Couvercle de barre de fourchette	Coperchietto selettore	Tapa barra de la horquilla	-
1600 0670	1	5568506	"O" ring	"O" ring	Joint torique	"O" ring	Junta tórica	2
1600 0675	2	MX-8-0825	Screw M8 x 25	Schraube	Vis	Vite	Tornillo	-
1604	16	MX-8-1049	Bolt M10 x 55	Schraube	Boulon	Vite	Perno	-
1606	1	2770471	Speedometer rotor	Tachometerrotor	Rotor de tachymètre	Rotore tachimetro	Rotor del velocimetro	-
1608	1	2770862	Cover rear bearing	Tachometergehäuse	Boîtier de tachymètre	Supporto tachimetro	Alojamiento del velocimetro	-
1610	1	2770878 (120525)	Gasket	Dichtung	Joint	Guarnizione	Junta	2
1612	5	MX-8-1030	Screw M10 x 70	Schraube	Vis	Vite	Tornillo	-
1613	1	MX-8-1044	Screw M10 x 70	Schraube	Vis	Vite	Tornillo	-
1615	1	F96063	Washer	Scheibe	Rondelle	Rondella	Arandela	-
1616	1	2770005	Spacer	Distanzstück	Entretoise	Distanziale	Separador	-
1618	1	2770491 (120524)	Seal Output	Dichtring	Joint	Guarnizione	Sellaje	2
1620	1	2770464	Output flange	Abtriebsflansch	Bride de sortie	Flangia di uscita	Brida de salida	-
1622	1	2770417	Clamp plate	Halteplatte	Plaque de serrage	Disco di fermo	Placa de la brida	-
1624	2	MX-7-1202	Screw M12 x 60	Schraube	Vis	Vite	Tornillo	-

Rear Case Assembly, Nachschaltgruppen-Gehäuse, Carter Arriere Assemble, Cómlessivo Scatola posteriore, Conjunto Tapa Trasera

s-06/1-03

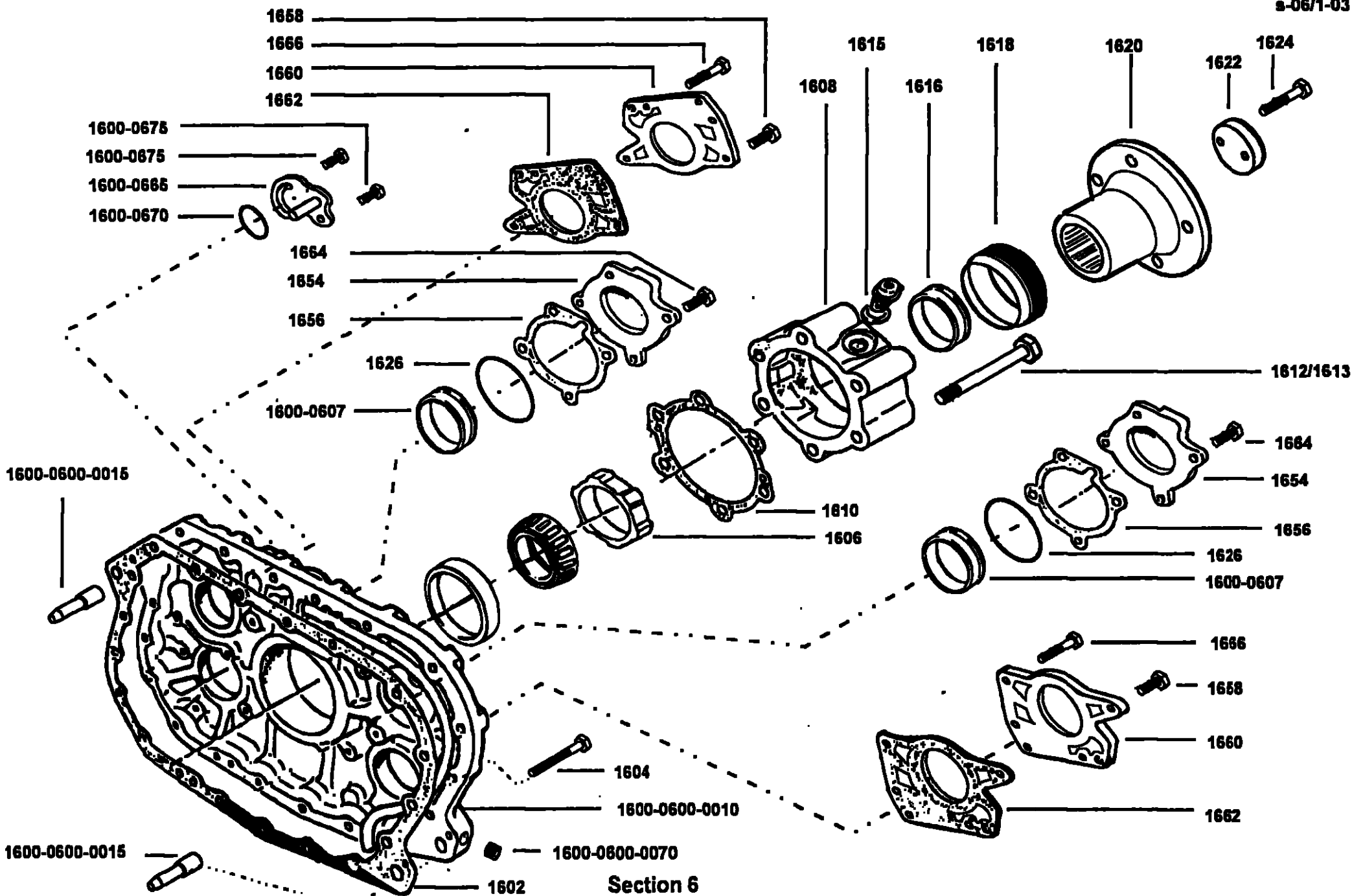

Sequence No	Qty	Part No	English	Deutsch	Francais	Italiano	Español	Stock Qty
1626	2	K-2805	Shim Kit	Zwischenring	Entretoise	Anello di registro	Separador	2
1654	2	4302320	Auxillary countershaft bearing cover	Lagerdeckel Nachschaltgruppen Vorgelegwelle	Couvercle de roulement de transmission auxiliaire	Coperchio cuscinetto contralbero ausiliario	Tapa del cojinete auxiliar del eje secundario	-
1656	2	4302246 (120525)	Gasket Rear bearing cover	Dichtung	Joint	Guarnizione	Junta	2
1658	8	MX-8-1047	Screw M10 x 35	Schraube M10 x 35	Vis M10 x 35	Vite M10 x 35	Tornillo M10 x 35	-
1660	2	2770345	PTO cover	Deckel Nebenantriebe	Couvercle de PMT	Coperchio Pdf	Tapa de la 'PT'	-
1662	2	2770346 (120525)	Gasket PTO cover	Dichtung	Joint	Guarnizione	Junta	2
1664	9	MX-8-1047	Screw M10 x 35	Schraube	vis	Vite	Tornillo	-
1666	3	MX-8-1050	Screw M10 x 80	Schraube M10 x 80	Vis M10 x 80	Vite M10 x 80	Tornillo M10 x 80	-

Auxiliary drive gear Assy, AUX Antriebszahnrad, AUX Pignon de commande, AUX Ingranaggio comando, AUX Engranaje conductor **'S SERIES**

s-0771-01

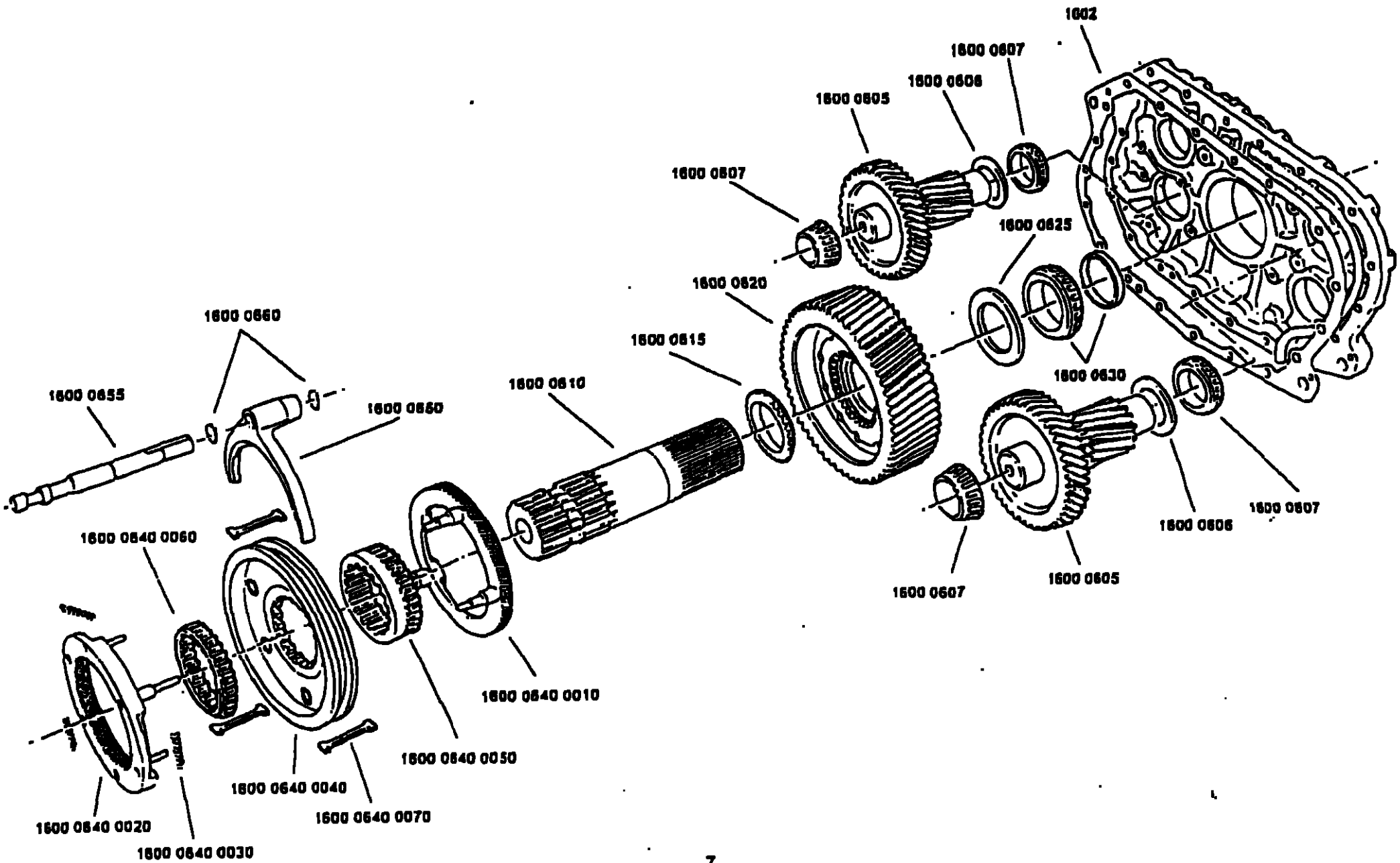

Sequence No	Qty	Part No	English	Deutsch	Francals	Italiano	Español	Stock Qty
1600 0605	2	U2771185	Auxiliary countershaft assy	Vorgelegewelle Nachschaltgruppe kompl.	Arbre secondaire auxiliaire	Contralbero ausiliario	Conjunto auxiliar de eje secundario	-
1600 0610	1	E-1034-130	Auxiliary mainshaft	Nachschaltgruppen- Hauptwelle	Arbre principal auxiliaire	Albero ausiliario	Eje principal auxiliar	-
1600 0615	1	E-1025-171	Splined washer	Nutenscheibe	Rondelle cannelée	Rondella dentata	Arandela postiza	-
1600 0620	1	2771803	Reduction gear	Untersetzungsrad	Pignon de réduction	Ingranaggio riduttore	Ingranaje de reducción	-
1600 0625	1	E-1025-173 (120520)	Thrust washer	Druckscheibe	Rondelle de poussée	Rondella di spallamento	Arandela de empuje	1
1600 0630	1	5556503 (120520)	Auxiliary mainshaft brg	Lager Nachschaltgruppen Hauptwelle	Roulement d'arbre principal auxiliaire	Cuscinetto albero ausiliario	Cojinete auxiliar del eje principal	-
1602	1	2770945 (120525)	Gasket Rear Hsg	Dichtung	Joint	Guarnizione	Junta	1
1600 0606	2	2770172	Retaining washer	Distanzstück	Entretoise	Distanziale	Separador	-
1600 0607	4	21343 (120523) (120520)	Bearing	Lager	Roulement	Cuscinetto	Cojinete	2
1600 0640 0010	1	U2771411 (120521)	Range reduction synchroniser assy	Synchronring untersetzter Bereich	Synchro de réduction de gamme	Sincronizzatore gamma	Conjunto de sincronización de reducción de gama	1
1600 0640 0020	1	U2771329 (120521)	Range direct synchroniser assy	Synchronring Direktbereich	Synchro direct de gamme	Compl. sincronizzatore gamma	Conjunto del sincronizador directo de gama	1
1600 0640 0030	3	14897 (120521)	Spring	Feder	Ressort	Molla	Muelle	3
1600 0640 0040	1	2771330 (120521)	Clutch plate	Kupplungsscheibe	Plateau d'embrayage	Disco di innesto	Placa de embrague	-
1600 0640 0050	1	2771808 (120521)	Range reduction clutch	Kupplung untersetzter Bereich	Crabot de réduction de gamme	Manicotto riduttore	Embrague de reducción de gama	-
1600 0640 0060	1	2770654 (120521)	Range direct clutch	Kupplung Direktbereich	Crabot direct de gamme	Manicotto presa diretta	Embrague directo gama	-
1600 0640 0070	3	2770281 (120521)	Range retainer	Bereichs-Riegel	Clavette de crabot	Tasselli	Retenedores de gama	3

'S SERIES

illary drive gear Assy, AUX Antriebszahnrad, AUX Pignon de commande, AUX Ingranaggio comando, AUX Engranaje conductor

s-07/1-01

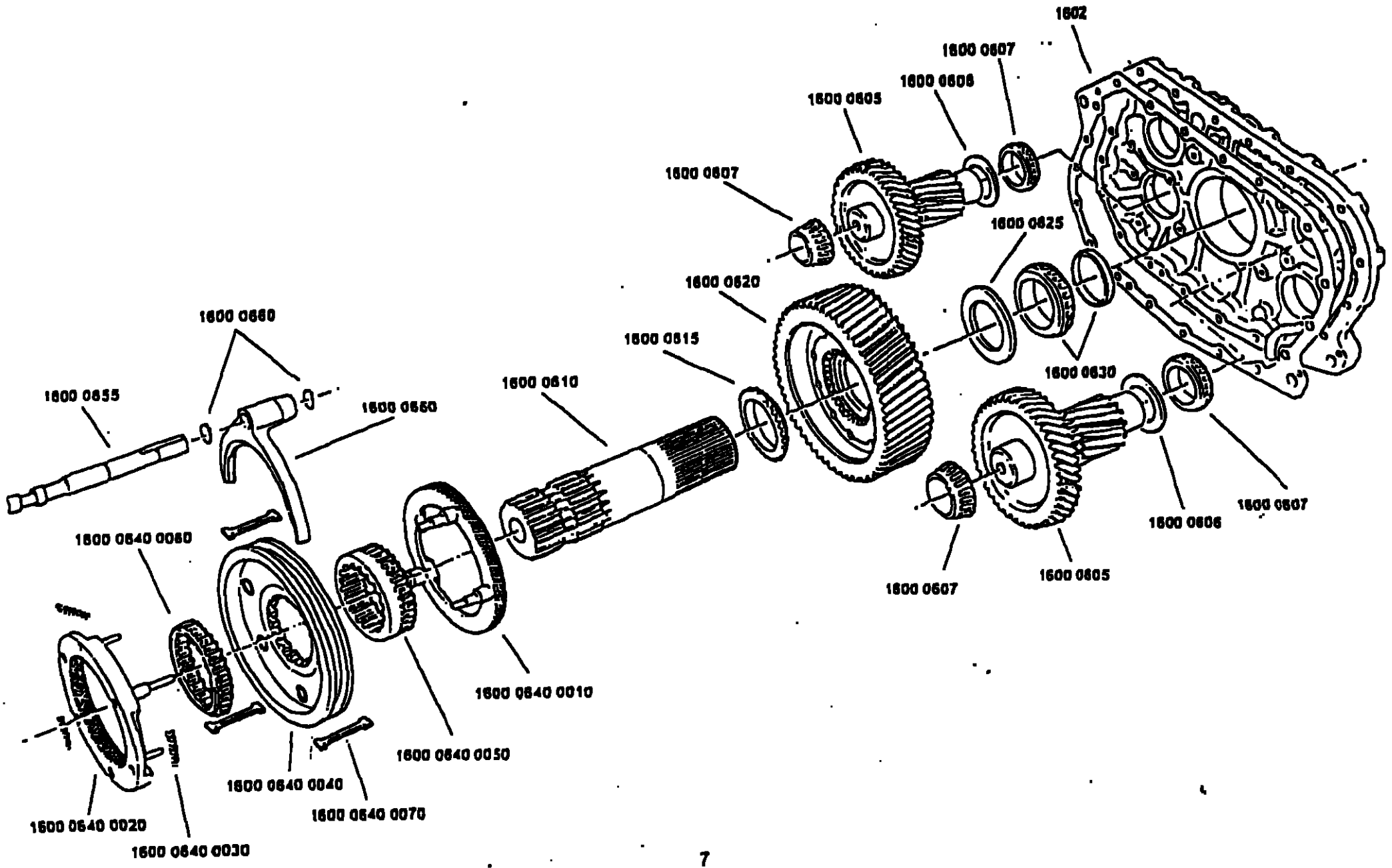

Sequence No	Qty	Part No	English	Deutsch	Francais	Italiano	Español	Stock Qty
1600 0650	1	2770186	Range yoke	Bereichs-Schaltgabel	Fourchette de gamme	Forcella cambio gamma	Horquilla de gama	-
1600 0655	1	2770672	Range yoke bar	Bereichs-Schaltstange	Barre de fourchette de gamme	Asta	Barra de la horquilla de gama	-
1600 0660	2	4302080	Circlip	Sicherungsring	Circlips	Anello elastico	Anillo elástico	2

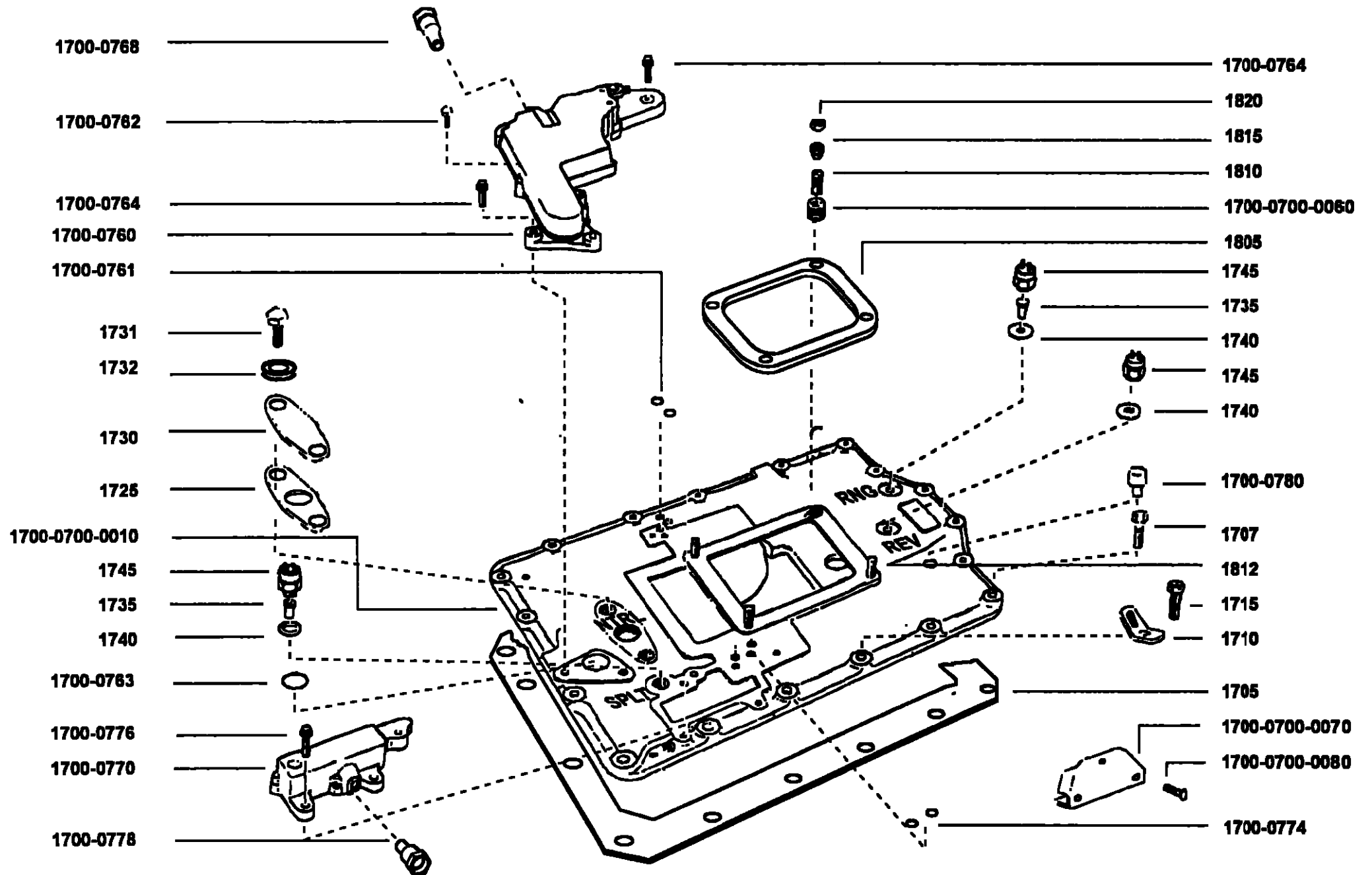

Section 12

Sequence No	Qty	Part No	English	Deutsch	Francais	Italiano	Español	Stock Qty
1700	Ref.	U2771615	Shift housing bar assy.	Schaltdeckel	Couvercle de changement de vitesse	Coperchio selettore	Tapa de varillas	-
1700 0700 0010	1	2771470	Shift bar housing	Schaltdeckel	Couvercle de changement de vitesse	Coperchio selettore	Tapa de varillas	-
1700 0700 0060	1	X2770323	Insert	Einslage	Insert	Inserto	Plaquita	
1700 0700 0070	1	2771146	Baffle plate					
1700 0700 0080	3	X8872604	Screw	Schraube	Boulon	Bullone	Perno	-
1700 0760	1	A-6395 (I20517)	Range module	Bereichs-Modul	Module de gamme	Commando selezione gamma	Modulo de gama	1
1700 0761	2	14197 (I20517)	"O" ring	"O" ring	Joint torique	"O" ring	Junta torique	2
1700 0762	3	MX-8-0835 (I20517)	Screw M8 x 35	Schraube M8 x 35	Vis M8 x 35	Vite M8 x 35	Tornillo M8 x 35	-
1700 0763	1	15569 (I20517)	"O" Ring					
1700 0764	1	MX-8-0825 (I20517)	Screw M8 x 25	Schraube M8 x 25	Vis M8 x 25	Vite M8 x 25	Tornillo M8 x 25	-
1700 0768	1	2770745	Adaptor	Adapter	Adaptateur	Adattore	Adaptador	2
1700 0770	1	U2770435 (I20542)	Splitter module	Splitter-Modul	Module de relais	Commando riduttore	Modulo splitter	1
1700 0774	2	14197 (I20542)	"O" ring	"O" ring	Joint torique	"O" ring	Junta torique	2
1700 0776	4	MX-8-0825 (I20542)	Screw M8 x 25	Schraube M8 x 25	Vis M8 x 25	Vite M8 x 25	Tornillo M8 x 25	-
1700 0778	1	2770744	Adaptor	Adapter	Adaptateur	Adattore	Adaptador	2
1700 0780	1	23605	Breather	Einblufter	Reniflard	Sfiatatoio	Respiro	-

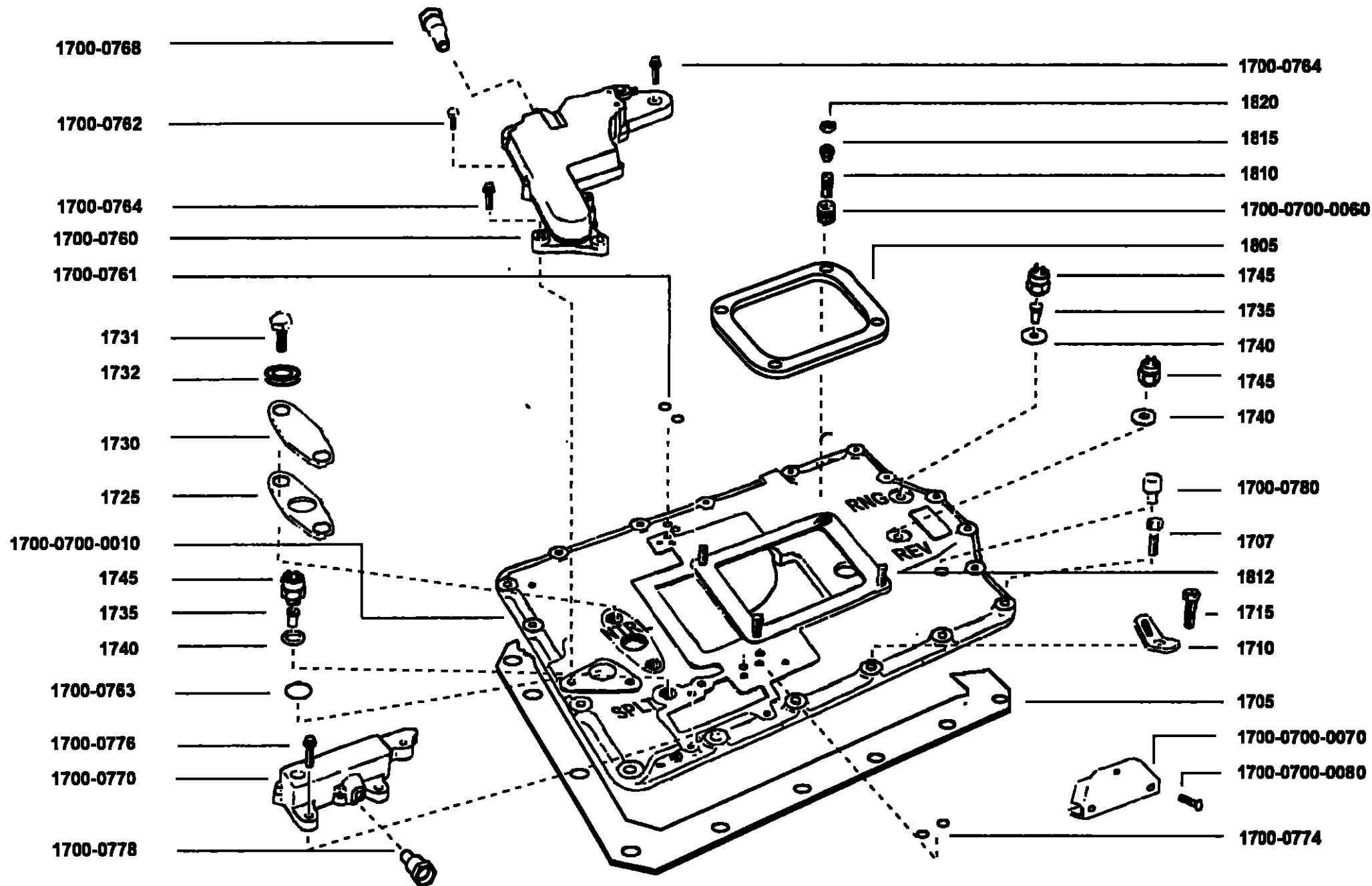

Section 12

Sequence No	Qty	Part No	English	Deutsch	Français	Italiano	Español	Stock Qty
1725	1	2771415 (120525)	Gasket-Interlock	Dichtung	Joint	Guarnizione	Junta	1
1730	1	2771284	Cover	Deckel	Couvercle	Coperchio	Tapa	-
1731	2	MX-8-0801	Screw M8 x 14	Schraube	Vis	Vite	Tornillo	-
1732	2	MX-10-0801	Washer M8	Scheibe	Rondelle	Rosetta	Arandela	-
1735	2	2770204	Pin	Stift	Goupille	Alberino	Pasador	-
1740	2	15900 (120525)	Gasket Rev/RSC switch	Dichtung	Joint	Guarnizione	Junta	3
1745	1	196040	Reverse switch	Druckschalter	Contracteur	Interruttore	Interruptor	3
1805	1	2771156 (120525)	Gasket Control	Dichtung	Joint	Guarnizione	Junta	1
1810	1	X11261	Stud M10 x 30	Stiftschraube	Goujon	Prigioniero	Esparrago	-
1812	3	2770300	Stud M10	Stichbolzen	Goujon	Prigioniero	Esparrago	-
1815	4	X11262	Conical nut	Mutter	Ecrou	Dado conico	Tuerca	4
1820	4	X11263	Locknut	Mutter	Contre-ecrou	Controlado	Tuerca de cierre	-
1705	1	2770137 (120525)	Gasket SB11	Dichtung	Joint	Guarnizione	Junta	1
1707	16	MX-8-1028	Screw M10 x 40	Schraube	Vis	Vite	Tornillo	-
1710	2	20815	Lifting eye	Hebeose	Patte de levage	Squadretta di sollevamento	Orificio de alzade	2
1715	2	MX-8-1048	Screw M10 x 45	Schraube	Vis	Vite	Tornillo	-

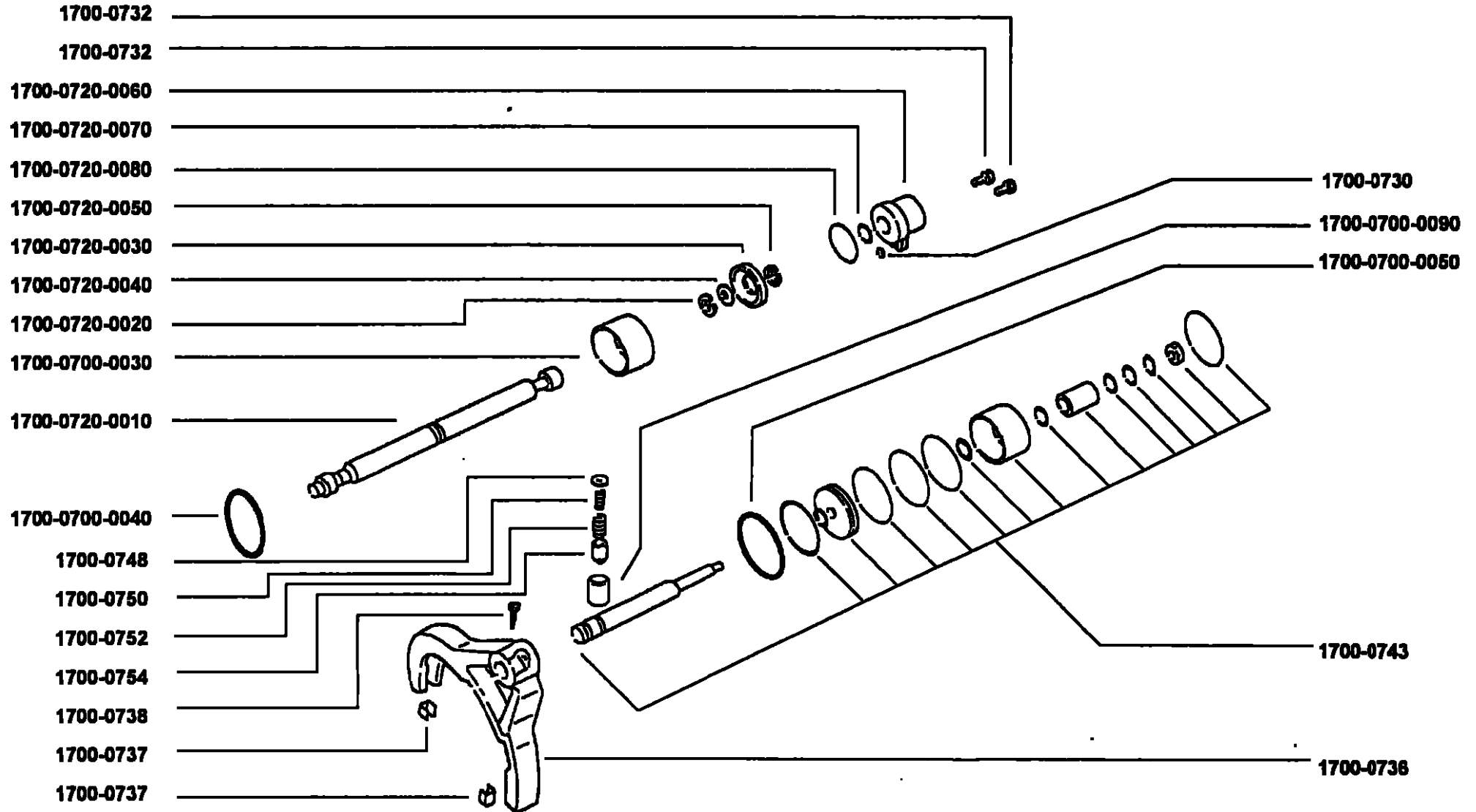

Range Cylinder, Splitter Cylinder,

Section 12b

Sequence No	Qty	Part No	English	Deutsch	Français	Italiano	Español	Stock Qty
1700 0700 0030	1	2771123	Range sleeve	Bereichs-Hülse	Manchon de gamme	Manicotto comando selez gamma	Casquillo de gama	-
1700 0700 (X)40	1	X2770203	Quadrang	Quadrang	Quadrang	Anello	Quadrang	2
1700 0700 0050	1	X2770069	Quadrang	Quadrang	Quadrang	Anello	Quadrang	2
1700 0700 0900	1	2771544	Sleeve Detent	Hülse arretier	Manchon	Manicotto	Casquillo	2
1700 0730	1	14197	"O" ring	"O" ring	Joint torique	"O" ring	Junta torique	2
1700 0732	2	X-8-1804M	Screw M8 x 30	Schraube	Vis	Vite	Tornillo	-
1700 0736	1	2770727	Splitter yoke	Splitter-Schaltgabel	Fourchette de relais	Forcella comando riduttore	Horquilla del splitter	-
1700 0737	2	2770139	Copper insert	Kupfereinlage	Insert cuivre	Inserto rame	Plaquita de cobre	2
1700 0738	1	2770919	Splitter screw	Splitter-Schraube	Vis de relais	Vite	Tornillo del splitter	-
1700 0743	1	U2771422	Splitter Cyl. assy.					1
1700 0748	1	2771418	Washer	Scheibe	Rondelle	Rosetta	Araudella	1
1700 0750	1	4302134	Spring	Feder	Ressort	Molla	Muelle	1
1700 0754	1	2771419	Plunger	Schieber	Plongeur	Nuttoloino	Vastago	1
1700 0720 0010	1	2770671	Range shift bar	Bereichs-Schaltstange	Barre du sélecteur de gamme	Asta seletttrice gamma	Varilla de gama	-
1700 0720 0020	1	4302080	Circlip	Sicherungsring	Circlips	Anello elastico	Anillo elástico	2
1700 0720 0030	1	2770089	Range piston	Bereichs-Kolben	Piston de gamme	Pistoncino comando selez gamma	Piston de gama	-
1700 0720 0040	1	X2770140	"O" ring	"O" ring	Joint torique	"O" ring	Junta tórica	2

Range Cylinder Assembly, Range Cylinder, Cylindre Range, Range Cillindro, Cillindro Range

Splitter Cylinder Assembly, Splitter Zylinder, Cylindre du Relais, Servocilindro, Cilindro Splitter

S- Series

s-12/2-04

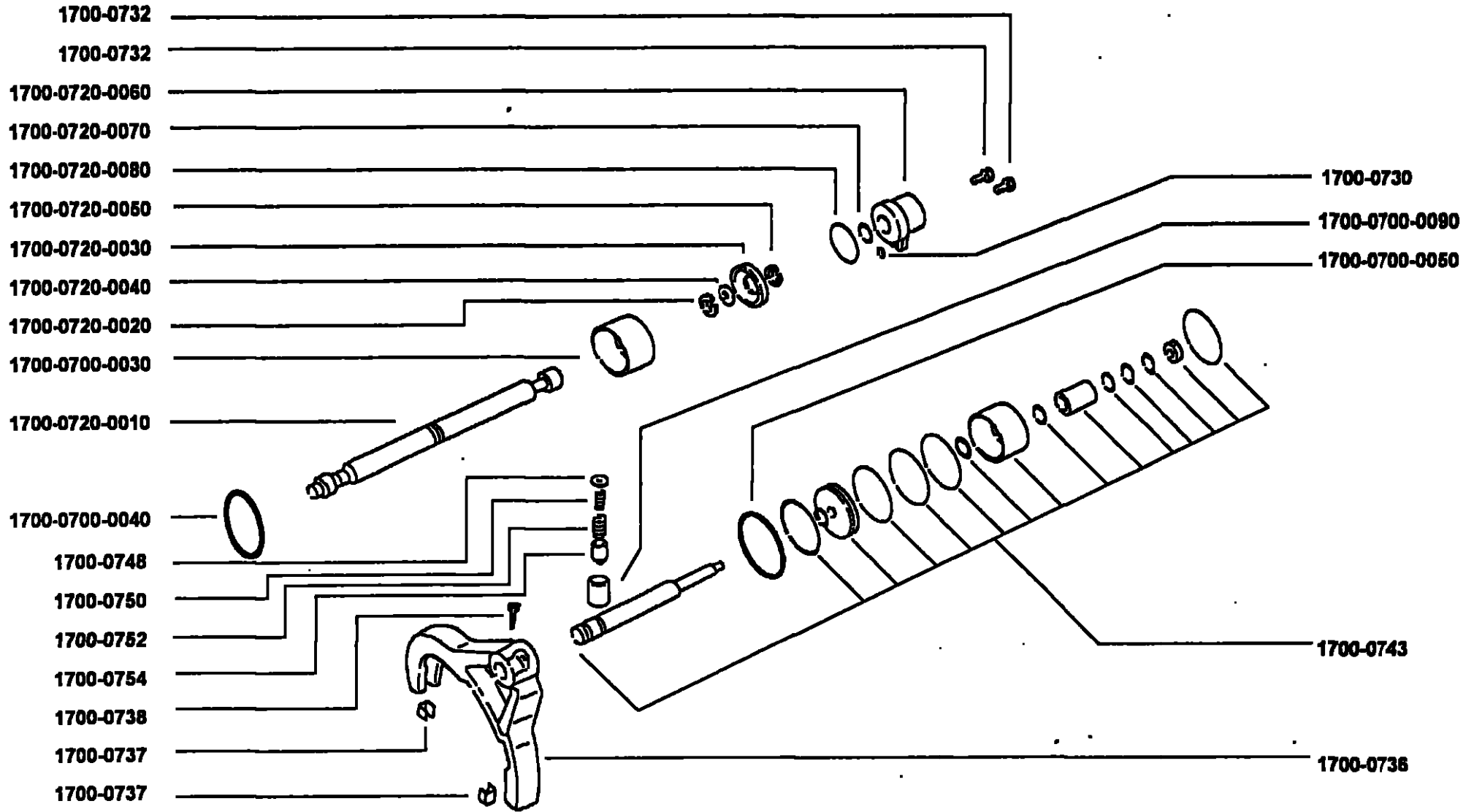

Sequence No	Qty	Part No	English	Deutsch	Francais	Italiano	Español	Stock Qty
1700 0720 0050	1	4302080	Circlip	Sicherungsring	Circlips	Anello elastico	Anillo elástico	2
1700 0720 0160	1	2771087	Range cover	Bereichs-Deckel	Couvercle de gamme	Coperchio comando selez gamma	Tapa de la gama	-
1700 0720 0070	1	X2770203	Quadring	Quadring	Quadring	Anello	Quadring	2
1700 0720 0080	1	X2770076	"O" ring	"O" ring	Joint torique	"O" ring	Junta tórica	2

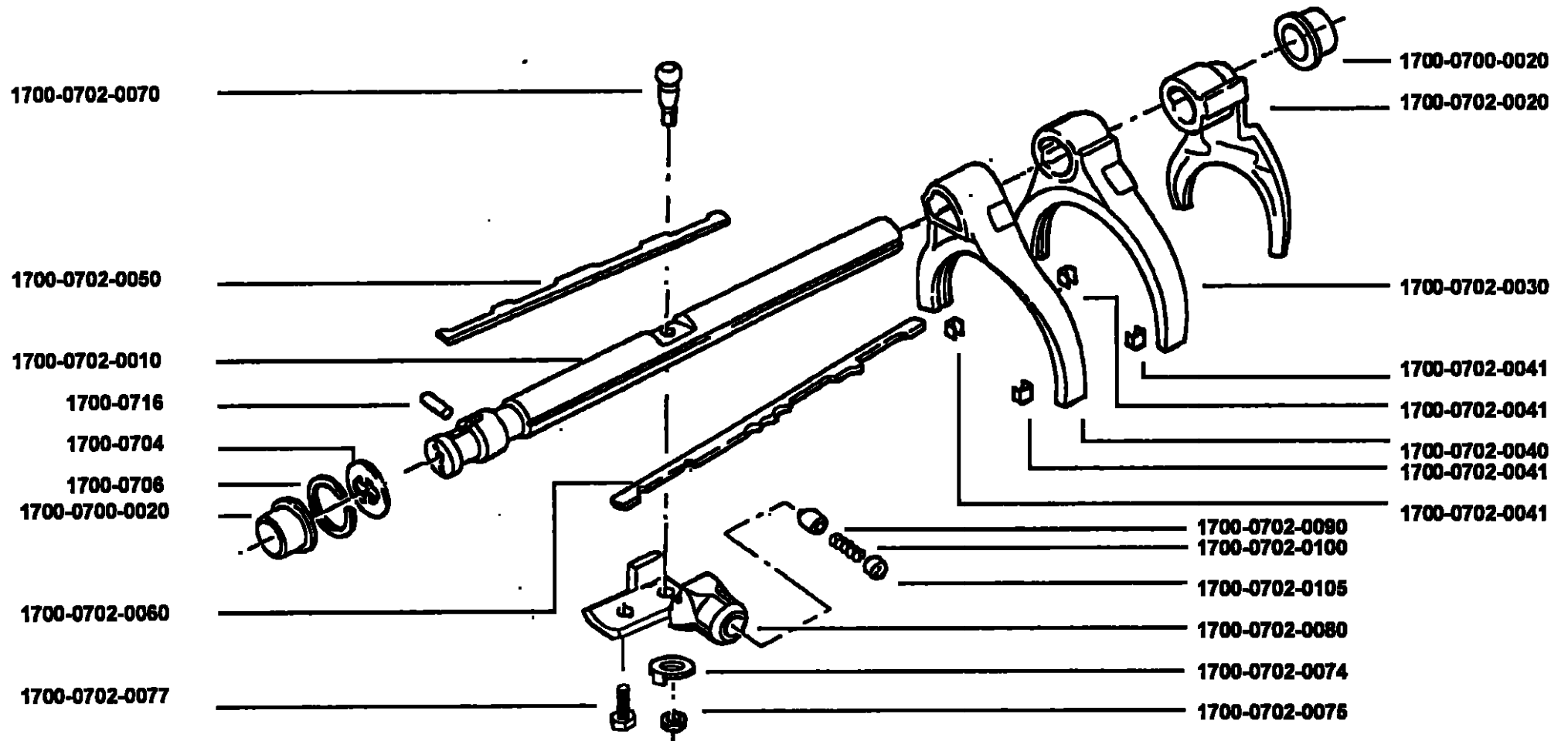

Selector Mechanism,

Section 12c

Sequence No	Qty	Part No	English	Deutsch	Francais	Italiano	Español	Stock Qty
1700 0700 0020	2	2770085	Bush	Buchse	Bague	Boccola	Casquillo	2
1700 0702 0010	1	2771264	Shift shaft	Schaltwelle	Axe du sélecteur	Asta selett. marcia	Varilla de cambios	-
1700 0702 0020	1	2770761	Yoke Reverse	Schaltgabel	Fourchette	Forcella	Horquilla	-
1700 0702 0030	1	2770762	Yoke 1st/2nd	Schaltgabel	Fourchette	Forcella	Horquilla	-
1700 0702 0040	1	2770763	Yoke 3rd/4th	Schaltgabel	Fourchette	Forcella	Horquilla	-
1700 0702 0041	4	2770138	Copper insert	Kupfereinlage	Insert cuivre	Inserto rame	Plaquita de cobre	2
1700 0702 0050	1	2771402	Shift key	Schaltklinke	Reglette du sélecteur	Chiavetta di comando	Chaveta de cambios	-
1700 0702 0060	1	2771416	Interlock key	Verriegelungskleine	Reglette de verrouillage	Chiavetta di consenso innesto	Chaveta de entrecierre	-
1700 0702 0070	1	2771075	Pin	Stift	Goupille	Spina	Pasador	-
1700 0702 0074	1	2771076	Tab Washer	Scheibe	Rondelle	Rosetta	Arandella	1
1700 0702 0075	1	MX-9-1001	Nut	Mutter	écrou	Dado	Tuerca	-
1700 0702 0077	1	MX-8-1014	Screw M10 x 25	Schraube	Vis	Vite	Tornillo	-
1700 0702 0080	1	2771263	Shift block	Schaltblock	Verron	Blocchetto	Bloque de cambio	-
1700 0702 0090	1	2770868	Plunger detent	Schieber	Plongeur	Nottoloino	Vástago	-
1700 0702 0100	1	2771170	Spring	Feder	Ressort	Molla	Muelle	1
1700 0702 0105	1	2770880	Plug	Stopfen	Bouchon	Tappo	Tapón	-
1700 0704	1	2771417	Cam Plate	Nockenscheibe	Plaque de came	Disco eccentrico	Placa de la leva	-
1700 0706	1	4302183	Circlip	Sicherungsring	Circlip	Anello elastico	Anillo elastico	2
1700 0716	1	2770084	Interlock pin	Verriegelungsstift	Goupille de verrouillage	Spina di consenso	Pasador de cierre	-

SERVICE KIT**T20519 Bearing Kit-Single Front Countershaft; Lager Kit vorlere Vorgelegewelle.**

DATE: 4/95

Qty	Part No.	English	Deutsch	Francais	Italiano	Espaniol
2	X2770467	Bearing, Front Countershaft	Lager	Roulement	Cuscinetto	Cojinete
1	K-2805	Shim Kit RTS	Distanzring	Entretoise	Distanziale	Separador

SERVICE KIT**T20520 Bearing Kit-RTS; Lager kit RTS.**

DATE: 4/95

Qty	Part No.	English	Deutsch	Francais	Italiano	Espaniol
2	X2770094	Bearing; Reverse Idler	Lager	Roulement	Cuscinetto	Cojinete
4	X2770467	Bearing; Front Cshaft	Lager	Roulement	Cuscinetto	Cojinete
4	21343	Bearing; Rear Cshaft	Lager	Roulement	Cuscinetto	Cojinete
1	K-2805	Shim Kit-RTS	Distanzring	Entretoise	Distanziale	Separador
1	5566503	Bearing; Input Shaft	Lager	Roulement	Cuscinetto	Cojinete
1	E-1025-173	Thrust Washer	Stuetzscheibe	Rondelle de poussee	Rondella di spinta	Arandela de empuje
1	5556503	Bearing; Output Shaft	Lager	Roulement	Cuscinetto	Cojinete
2	X2770760	Thrust Bearing Splitter	Stuetzscheibe	Rondelle de poussee	Rondella di spinta	Arandela de empuje
1	2770774	Thrust Bearing Splitter	Stuetzscheibe	Rondelle de poussee	Rondella di spinta	Arandela de empuje

SERVICE KIT T20523 Bearing Kit-Single Rear Countershaft; Lager Kit-hintere Vorgelegewelle
DATE: 4/95

Qty	Part No.	English	Deutsch	Francais	Italiano	Espaniol
2	21343	Bearing, Rear Countershaft	Lager	Roulement	Cuscinetto	Cojinete
1	K-2805	Shim Kit RTS	Distanzring	Entretoise	Distanziale	Separador

SERVICE KIT T20524 Seal Kit-RTS: Dichtring Kit RTS
DATE: 4/95

Qty	Part No.	English	Deutsch	Francais	Italiano	Espaniol
1	2770218	Seal; Input Shaft	Dichtring-Eingang	Joint d'etancheite	Guarnizione tenuta	Reten
1	2770491	Seal; Output Shaft	Dichtring-Ausgang	Joint d'etancheite	Guarnizione tenuta	Reten
1	F96181	Seal; Control	Dichtring-Schaltung	Joint d'etancheite	Guarnizione tenuta	Reten

SERVICE KIT T20517 Range Module Kit- 16 Spd HH; Gruppenventil Kit-RTS
DATE: 10/95

Qty	Part No.	English	Deutsch	Francais	Italiano	Espaniol
1	A-6395	Range Module	Gruppenventil			
2	14197	O Ring	O Ring	Joint Torique	Guaranizione Toroidale	Junta torica
1	15569	O Ring	O Ring	Joint Torique	Guaranizione Toroidale	Junta torica
3	MX-8-0835	Screw	Schraube	Vis	Vite	Tornillo
1	MX-8-0825	Screw	Schraube	Vis	Vite	Tornillo

SERVICE KIT
DATE: 5/95

T20542 MAN RTSO S-Series Spltr Kit

Qty	Part No.	English	Deutsch	Francais	Italiano	Espaniol
1	U2770435	Splitter Module	Splitter Ventil			
2	14197	O-Ring	O-Ring	Joint Torique	Guaranizione Toroidale	Junta torica
4	MX-8-0825	Screw	Schraube	Vis	Vite	Tornillo

SERVICE KIT
DATE: 10/95

T20522 1st/2nd Synchro Kit-RTS
1/2 Synchroniseur assemble
1/2 Conjunto sincronizador

1/2 Synchron Kit komplett.
1/2 Complessivo sincronizzatore.

Qty	Part No.	English	Deutsch	Francais	Italiano	Espaniol
1	U2770651	1/2 Synchro	Synchronisierung	Synchroniseur	Complessivo	Sincronizador
3	2770200	Spring	Feder	Ressort	Molla	Muelle
3	2770113	Plunger	Schieber	Plonger	Nottolino	Vastago
3	2770665	Retainer	Riegel	Clavette	Tassello	Retenedor

SERVICE KIT
DATE: 4/95

T20515 3rd/4th Synchro Kit-RTS
3/4 Synchroniseur assemble
3/4 Conjunto sincronizador

3/4 Synchron Kit komplett.
3/4 Complessivo sincronizzatore.

Qty	Part No.	English	Deutsch	Francais	Italiano	Espaniol
1	U2770884	3/4 Synchro	Synchronisierung	Synchroniseur	Complessivo	Sincronizador
3	2770200	Spring	Feder	Ressort	Molla	Muelle
3	2770113	Plunger	Schieber	Plonger	Nottolino	Vastago
3	2770276	Retainer	Riegel	Clavette	Tassello	Retendor

SERVICE KIT
DATE: 12/95

T20516 Splitter Synchro Kit-RTSO: Synchron Kit Splitter-RTSO

Qty	Part No.	English	Deutsch	Francais	Italiano	Espaniol
1	U2771681	Synchro Assy	Synchronring	Synchro	Sinconizzatore	Sincronizador
3	277119	Spring	Feder	Ressort	Molla	Muella
3	2770673	Pin-Guide spring				
1	2771687	Splitter Clutch Plate	Platte	Plaque	Piastra	Placa
1	U2771680	Synchro Assy	Synchronring	Synchro	Sinconizzatore	Sincronizador

SERVICE KIT
DATE: 11/95

T20521 Range Synchro Kit-RTS: Synchron Kit Gruppe RTS

Qty	Part No.	English	Deutsch	Francais	Italiano	Espaniol
1	U2771411	Range Rdn Synchro	Synchronring-U	Synchro	Sinconizzatore	Sincronizador
3	14897	Spring	Feder	Ressort	Molla	Muella
1	2771330	Range Clutch Plate	Platte	Plaque	Piastra	Placa
1	U2771329	Range Drct Synchro	Synchronring-D	Synchro	Sinconizzatore	Sincronizador
1	2771808	Clutch-SlidingRdn	Kupplung direkt			
1	2770654	Clutch-Sliding Aux Drv	Kupplung-U			
3	2770281	Range Retainer	Riegel	Clavette	Tassello	Retenedor

SERVICE KIT**T20524 Seal Kit-RTS: Dichtring Kit-RTS**

DATE: 4/95

Qty	Part No.	English	Deutsch	Francais	Italiano	Espaniol
1	2770218	Seal; Input Shaft	Dichtring Eingang	Joint d etancheite	Guarnizione tenuta	Reten
1	2770491	Seal; Output Shaft	Dichtring Ausgang	Joint d etancheite	Guarnizione tenuta	Reten
1	F96181	Seal; Control	Dichtring Schaltung	Joint d etancheite	Guarnizione tenuta	Reten

SERVICE KIT**K-2805 Shim Kit-RTS: Distanzring Kit-RTS**

DATE: 4/95

Qty	Part No.	English	Deutsch	Francais	Italiano	Espaniol
1	21452	Shim	Distanzring	Entretoise	Distanziale	Separador
1	21453	Shim	Distanzring	Entretoise	Distanziale	Separador
1	21454	Shim	Distanzring	Entretoise	Distanziale	Separador
1	21455	Shim	Distanzring	Entretoise	Distanziale	Separador
1	21456	Shim	Distanzring	Entretoise	Distanziale	Separador
1	21457	Shim	Distanzring	Entretoise	Distanziale	Separador
1	21458	Shim	Distanzring	Entretoise	Distanziale	Separador
1	21459	Shim	Distanzring	Entretoise	Distanziale	Separador
1	21460	Shim	Distanzring	Entretoise	Distanziale	Separador
1	21461	Shim	Distanzring	Entretoise	Distanziale	Separador
1	21684	Shim	Distanzring	Entretoise	Distanziale	Separador
1	21685	Shim	Distanzring	Entretoise	Distanziale	Separador

SERVICE KIT**T20525 Gasket Kit-RTS: Dichtung Kit-RTS****DATE: 5/95**

Qty	Part No.	English	Deutsch	Francais	Italiano	Espaniol
1	1684	Gasket; 6 bolt P.T.O.	Dichtung	Joint	Guarnizione	Junta
1	4302810	Gasket; 8 bolt P.T.O.	Dichtung	Joint	Guarnizione	Junta
1	2770944	Gasket; oil pump cover	Dichtung	Joint	Guarnizione	Junta
1	2770968	Gasket; Clutch Housing	Dichtung	Joint	Guarnizione	Junta
2	17179	Gasket; Switch	Dichtung	Joint	Guarnizione	Junta
2	15900	Gasket; Switch	Dichtung	Joint	Guarnizione	Junta
1	2771415	Gasket; Interlock	Dichtung	Joint	Guarnizione	Junta
1	2770945	Gasket; Rear Housing	Dichtung	Joint	Guarnizione	Junta
1	2770878	Gasket; Speedo Housing	Dichtung	Joint	Guarnizione	Junta
2	4302246	Gasket; Rear Brg Cover	Dichtung	Joint	Guarnizione	Junta
2	2770346	Gasket; P.T.O. Cover	Dichtung	Joint	Guarnizione	Junta
1	2770137	Gasket; Shift Bar Hsg	Dichtung	Joint	Guarnizione	Junta
1	2771156	Gasket; Control	Dichtung	Joint	Guarnizione	Junta
1	2770830	Gasket; Control Detent	Dichtung	Joint	Guarnizione	Junta