

EATON
TWIN SPLITTER TRANSMISSION
 Illustrated Parts List
 Ersatzteilleste
 Catalogue Rechange
 Catalogo Ricambi
 Catalogo de Piezas de Recambio

DAF
TSO 12612A
Y2000826

2/95

Section	English	Deutsch	Francés	Italiano	Español	Section
1	Main Case Assy	Gehäuse Hauptgetriebe	Ensemble Carter Principal	Scatola Principale	Conjunto Carcasa Principal	1
2	Input Shaft Assy	Antriebswelle	Arbre D'Entree	Albero Di Entrata	Eje Primario	2
3	Mainshaft Assy	Hauptwelle	Arbre Principal Assemble	Albero Principale Completo	Conjunto Eje Principal	3
4	Front Countershaft Assy	Vorgelegewelle	Arbre Secondaire Assemble	Contralbero Completo	Conjunto Eje Secundario	4
5	Reverse Idler Gear Assy	Rückwärtsgang-Umkehrrad	Marche Arriere	Retro Marcia	Conjunto Inversor Ma	5
6	Rear Case Assembly	Nachschaltgruppen-Gehäuse	Carter Arriere Assemble	Scatola Posteriore	Conjunto Tapa Trasera	6
7	Auxiliary Countershaft Assy	Vorgelegewelle Nachschaltgruppe	Arbre Secondaire Auxiliare	Contralbero Auxil Completo	Conjunto Eje Secundario Aux	7
9	Upshaft Braks Assy	Getriebe Bremse	Frein D'Inertie	Freno D'Inerzia	Freno De Cambio Hacia Arriba	9
10	Splitter Cylinder	Splitter Zylinder	Cylindre Du Relais	Servo Cilindro	Cilindro Splitter	10
12	Shift Bar Housing Assy	Schaldeckel	Couvercle de Changement de Vitesse	Coperchio Seletorre	Tapa de Varillas	12
13	Control	Fernschaltung	Commande a Distance	Complessivo Comando	Conjunto Control Remoto	13
0	Air system	Luftsystem	System Pneumatique	Impianti Pneumatici	Systemas Neumaticos	0
0	Power Steering Pump Drive	Lenkpumpen-Adapter	Pompe De Direction Assiste	Comando Pompa Idroguida	Bomba De Direccion	0
0	Clutch housing assy	Kupplungsgehäuse	Cloche d'embroyage	Cuppa frizione	Campana embrague	0
Note	Stocking quantity shows recommended quantities for 25 transmissions	Lagerempfehlung für 25 Getriebe	Quantite de stockage pour 25 unite	Quantita per 25 cambi	Cant. stock para 25 cajas de cambio	
	# ORDER	# BESTELLEN	# COMMANDER	# ORDINAIRE	# PEDIR	

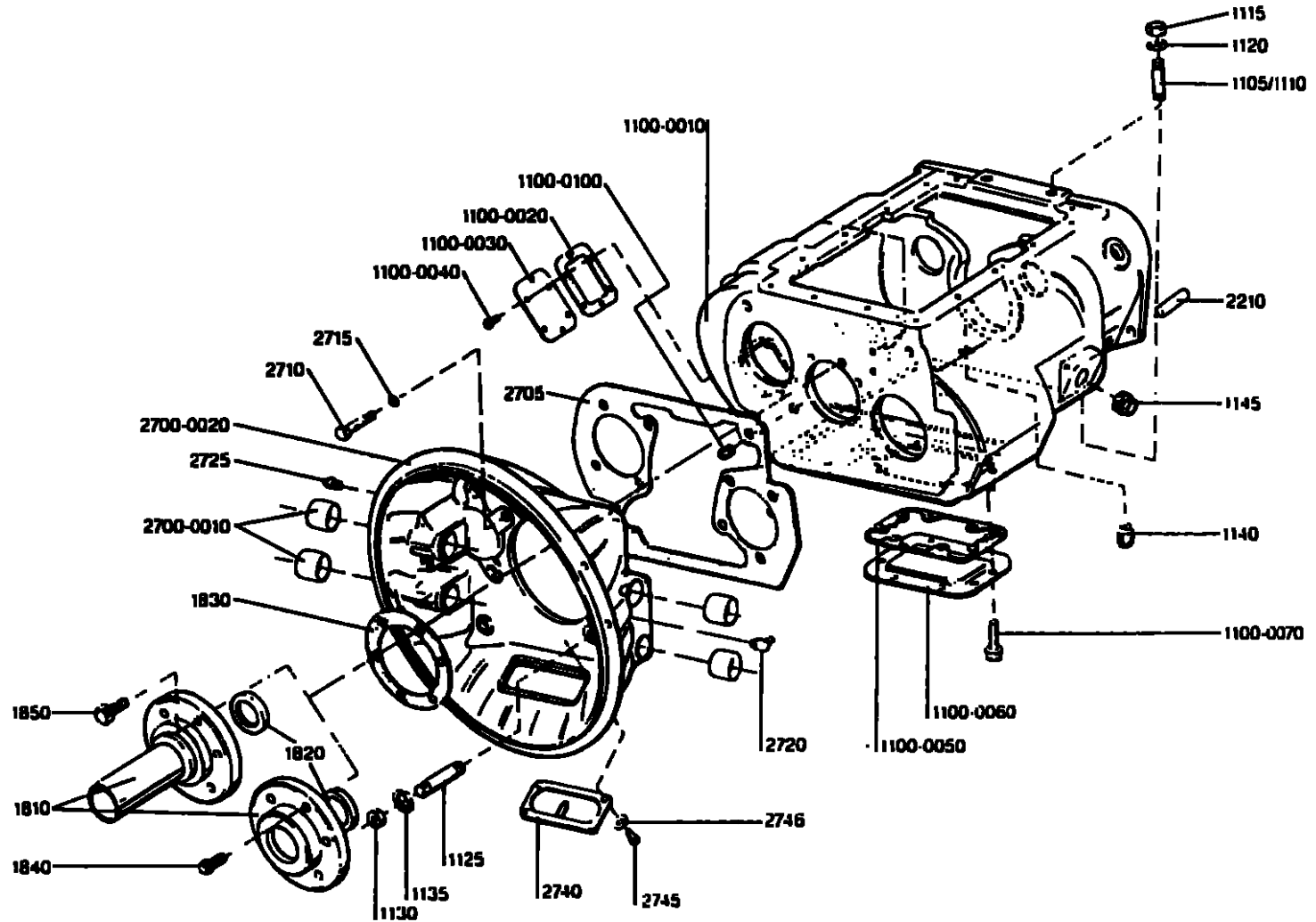

Main Case Assembly, Gehäuse Hauptgetriebe, Ensemble Carter Principal, Scatola Principale, Conjunto Principal

Sequence No Sequence Nr Sequela No Secuencia No	Qty Anzahl Qte Qta No.	Part No Teil Nr Piece No Rif No. Cat	English	Deutsch	Francais	Italiano	Espanol	Stock Qty Lager Empf Qte de Stockage Quantita Cant. Stock
1100	1	U2002015	Main Case Assy	Getriebegehäuse Assy	Carter de boîte Assy	Scatola cambio Assy	Envolvente Assy	1
1100-0010	1	2005247	Main Case	Getriebegehäuse	Carter de boîte	Scatola cambio	Envolvente	1
1100 0020	1	1884	Gasket	Dichtung	Joint	Guarnizione	Junta	-
1100-0030	1	2005144	Cover	Abdeckplatte	Couvercle	Coperchio	Tapa	-
1100-0040	6	X11248	Screw M10 x 20	Schraube	Vis	Vite	Tornillo	-
1100-0050	1	4302810	Gasket	Dichtung	Joint	Guarnizione	Junta	-

Main Case Assembly, Gehäuse Hauptgetriebe, Ensemble Carter Principal, Scatola Principale, Conjunto Principal

Sequence No	Qty	Part No	English	Deutsch	Francais	Italiano	Espanol	Stock Qty
1100 (X)60	1	4302809	Cover	Deckel	Couvercle	Copertura	Tapa	-
1100-0070	8	X2011547	Screw M12 x 26	Schraube	Vis	Vite	Tornillo	-
1100-0100	1	X-12-802	Plug	Stopfen	Bouchon	Tappo	Tapon	-
1105/1100	0	X2014113	Stud M16 x 56	Stiftschraube (56mm)	Goujon (56mm)	Prigionero (56mm)	Esparrago (56mm)	-
1115	0	X11618	Nut M16	Mutter	Ecrou	Dado	Tuerca	-
1120	0	X11617	Spring Washer M16	Federscheibe	Rondelle elastique	Rosetta elastica	Arandela elastica	-
1125	6	X2014101	Stud M16 x 62	Stiftschraube	Goujon	Prigionero	Esparrago	-
1126	0	X2014123	Stud M16 x 140	Stiftschraube	Goujon	Prigionero	Esparrago	-
1130	0	X2012002	Nut M16	Mutter	Ecrou	Dado	Tuerca	-
1135	0	X-10-1000	Washer	Federring	Rondelle grower	Rosetta elastica	Arandela elastica	-
1140	1	X14166	Magnetic drain plug	Verschlusschraube	Bouchon aimante	Tappo di scarico	Tapon magnetico	-
1145	1	X2013509	Filler plug	Einfallschraube	Bouchon rempl. d'huile	Tappo rempl. olio	Tapon	-
1810	1	2005223	Front bearing cover	Deckel	Couvercle de roulement	Coperchio cuscinetto	Tapa primario	1
1820	1	19111	Oil seal	Dichtung	Joint d'etancheite	Para olio	Reten	2
1830	1	2005576	Gasket	Dichtung	Joint	Guarnizione	Junta	2
1840	4	X2011609	Screw washer M10 x 33	Schraube/Federring	Vis/Rondelle grower	Vite/rosetta	Tornillo/arandela	-
1850	2	X2011614	Screw/washer M10 x 33	Schraube/Federring	Vis/Rondelle grower	Vite/rosetta	Tornillo/arandela	-
2210	2	14334	Dowel Pin	Passstift	Goupille	Spina centraggio	Espiga guia	-
2705	0	20822	Gasket	Dichtung	Joint	Guarnizione	Junta	-
2710	4	X2011610	Cap screw M12 x 40	Sechskantschraube	Vis	Vite	Tornillo	-
2715	4	X2012503	Lockwasher M12	Federring	Rondelle grower	Rosetta elastica	Arandela elastica	-

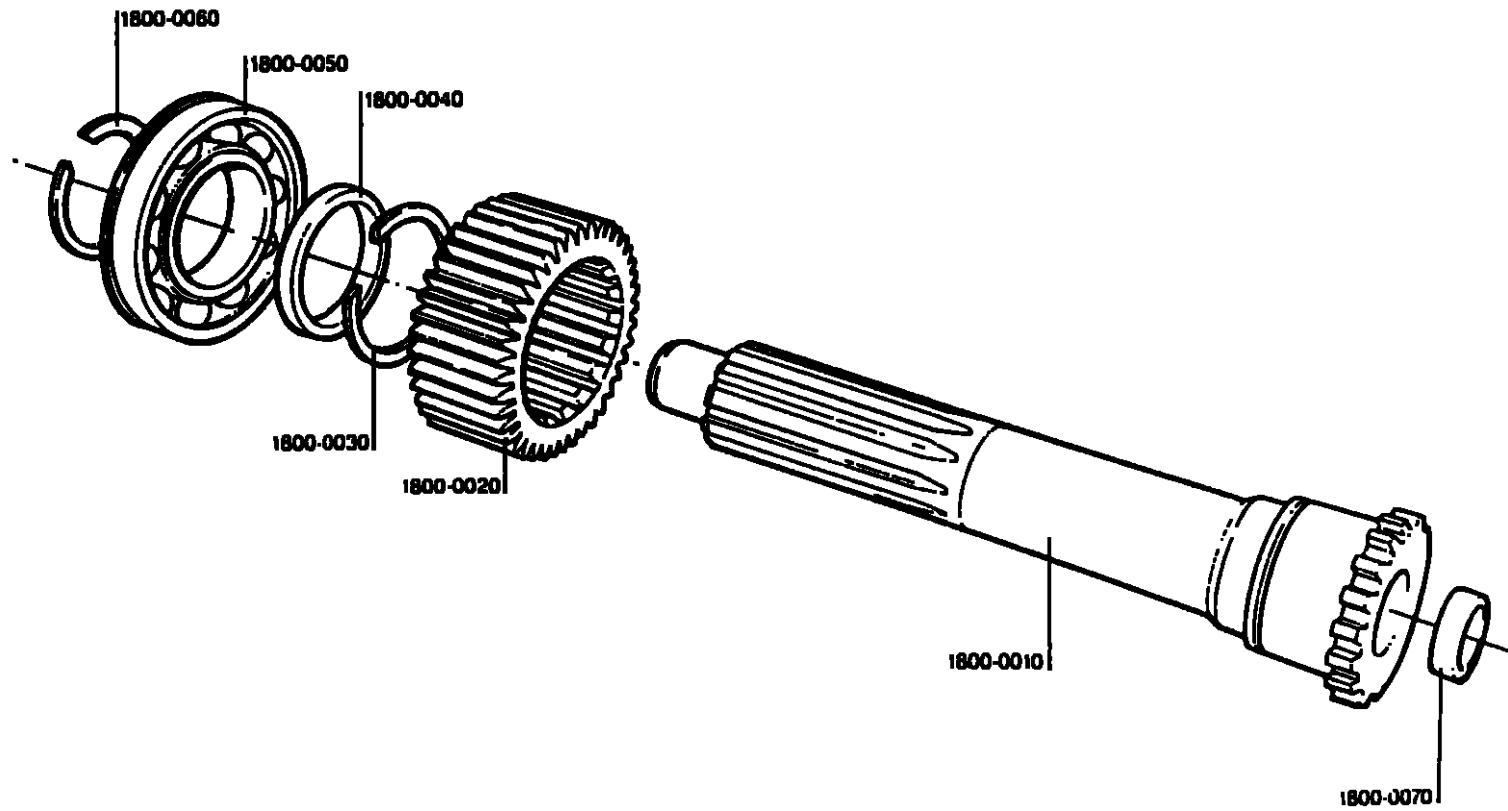

Input Shaft Assembly, Antriebswelle, Arbre d'Entree, Albero di Entrata, Eje Primario

Sequence No	Qty	Part No	English	Deutch	Francaise	Italiano	Espaniol	Stock Qty
1800	-	U2002578	Input shaft assembly	Abtriebswelle	Arbu d'entree	Albero entrata	Eje primario	1
1800-0010	1	2006007	Input shaft	Abtriebswelle	Arbe d'entree	Albero entrata	Eje primario	1
1800-0020	1	2005119	Drive Gear	Antriebsrad	Pignon d'entree	Ruoto dentata	Engranaje conductor	1
1800-0030	1	14289	Snap ring	Sicherungsring	Circlips	Anello di sicurezza	Anillo elastico	2
1800-0040	1	16396	Spacer	Distanzscheibe	Entretoise	Anello distanziale	Espaciador	-
1800-0050	1	81504	Ball bearing	Lager	Roulement	Cuscinetto	Cojinete	2
1800-0060	1	16980	Snap ring	Sicherungsring	Circlips	Anello di sicurezza	Anillo elastico	2
1800-0070	1	2005808	Bush	Busche	Bague	Boccola	Casquillo	2

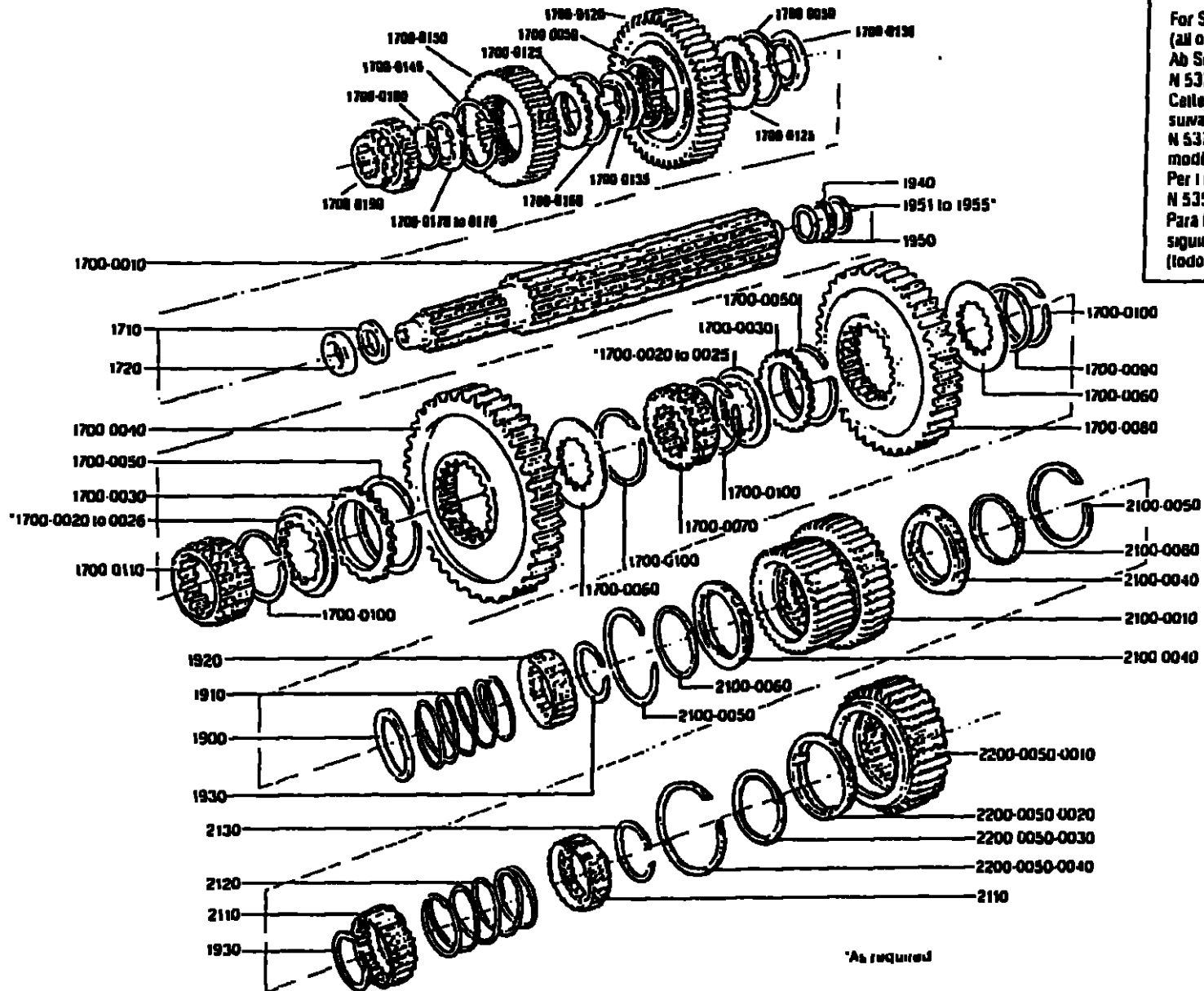

For Serial Nos N 535712 (ERF), N 537125 (all others) and above.
 Ab Seriennr. N 535712 (ERF) und ab N 537125 (alle anderen Modelle)
 Cette section intéresse les références suivantes: N 535712 et au dessus (ERF) N 537125 et au dessus (tous les autres modèles).
 Per i numeri di matricola fino a partire da N 535712 (ERF), o N 537125 (altri modelli);
 Para los números de serie: N 535712 y siguientes (ERF), N 537125 y siguientes (todos los restantes modelos)

Mainshaft Assembly, Hauptwelle, Arbre Principal Assemble, Albero Principale Completo, Conjunto Eje Principal

Sequence No	Qty	Part No	English	Deutsch	Francese	Italiano	Espanol	Stock Qty
1700	.	U2002594	Mainshaft Assembly	Hauptwelle	Arbre principal	Albero principale	Eje principal	1
1700-0010	1	2005990	Mainshaft	Hauptwelle	Arbre principal	Albero principale	Eje principal	1
1700-0020*	2	19911	Washer (6.30-6.35mm)	Distanzscheibe	Rondelle	Rondella	Arandela	3
1700-0020*	OR	19912	Washer (6.43-6.48mm)	Distanzscheibe	Rondelle	Rondella	Arandela	3
1700-0022*	OR	19913	Washer (6.55-6.60mm)	Distanzscheibe	Rondelle	Rondella	Arandela	3
1700-0023*	OR	19914	Washer (6.68-6.73mm)	Distanzscheibe	Rondelle	Rondella	Arandela	3
1700-0024*	OR	19915	Washer (6.80-6.86mm)	Distanzscheibe	Rondelle	Rondella	Arandela	3
1700-0025*	OR	19916	Washer (6.93-6.99mm)	Distanzscheibe	Rondelle	Rondella	Arandela	3
1700-0028*	OR	20011	Washer (6.22-6.17mm)	Distanzscheibe	Rondelle	Rondella	Arandela	3
1700-0030	2	18318	Spacer	Distanzscheibe	Entretoise	Anello distanziale	Espaciador	3
1700-0040	1	2005682	Gear 1st	Zahnrad 1-Gang	Pignon 1 ere	Ingranaggio 1a	Engranaje 1a	2
1700-0050	3	16798	Snap ring	Sicherungerring	Circlips	Anello di sicurezza	Anillo elastico	3
1700-0060	2	2005163	Washer	Scheibe	Rondelle	Rondella	Arandela	2
1700-0070	1	2005197	Sliding clutch	Schieberhufe	Crabot	Manicotto scorrevole	Carrete	3
1700-0080	1	2005683	Gear rev	Zahnrad R-Gang	Pignon Marche Ar	Ingranaggio retromarcia	Engranaje MA	3
1700-0090	1	2005198	Washer	Scheibe	Rondelle	Rondella	Arandela	3
1700-0100	4	X2014022	Snap ring	Sicherungerring	Circlips	Anello di sicurezza	Anillo elastico	4
1700-0110	1	2005492	Sliding clutch	Schieberhufe	Crabot	Manicotto scorrevole	Carrete	3
1700-0120	1	2005993	Gear 2nd	Zahnrad 2-Gang	Pignon 2eme	Ingranaggio 2a	Engranaje 2a	2
1700-0125	2	2005901	Spacer	Distanzscheibe	Entretoise	Anello distanziale	Espaciador	3
1700-0130	1	2005912	Spacer	Distanzscheibe	Entretoise	Anello distanziale	Espaciador	3
1700-0135	1	2005989	Spacer	Distanzscheibe	Entretoise	Anello distanziale	Espaciador	3
1700-0140	1	16798	Snap ring	Sicherungerring	Circlips	Anello di sicurezza	Anillo elastico	3
1700-0150	1	2005996	Gear 3rd	Zahnrad 3-Gang	Pignon 3eme	Ingranaggio 3a	Engranaje 3a	2
1700-0160	1	16798	Snap ring	Sicherungerring	Circlips	Anello di sicurezza	Anillo elastico	3

Sequence No	Qty	Part No	English	Deutsch	Francais	Italiano	Espanol	Stock Qty
1700-0169	1	2005918	Washer	Distanzscheibe	Rondelle	Rondella	Arandela	2
1700-0170*	1	2005919	Washer	Distanzscheibe	Rondelle	Rondella	Arandela	2
1700-0171*	OR	2005920	Washer	Distanzscheibe	Rondelle	Rondella	Arandela	2
1700-0172*	OR	2006043	Washer	Distanzscheibe	Rondelle	Rondella	Arandela	2
1700-0173*	OR	2005921	Washer	Distanzscheibe	Rondelle	Rondella	Arandelau	2
1700-0174*	OR	2005922	Washer	Distanzscheibe	Rondelle	Rondella	Arandel	2
1700-0175*	OR	2005923	Washer	Distanzscheibe	Rondelle	Rondella	Arandela	2
1700-0176*	OR	2005924	Washer	Distanzscheibe	Rondelle	Rondella	Arandela	2
1700-0180	1	16723	Snap ring	Sicherungsring	Circlips	Anello di sicurezza	Anillo elastico	
1700-0180	1	2005988	Sliding clutch	Schiebermuffe	Crabot	Mancotto scorrevole	Carrete	3
1710	1	2005805	Thrust washer	Druckscheibe	Rondelle de pousse	Rondella di spinta	Arandela de empuje	2
1720	1	2005730	Thrust washer	Druckscheibe	Rondelle de pousse	Rondella di spinta	Arandela de empuje	4
1900	1	2005093	Retainer	Stutzscheibe	Bague de retenue	Anello di ritagno	anillo apoyo	1
1910	1	2005091	Spring	Feder	Ressort	Molla	Muelle2	
1920	1	2005105	Sliding clutch	Schiebermuffe	Crabot	Mancotto scorrevole	Carrete	2
1930	2	2005832	Snap ring	Sicherungsring	Circlips	Anello di sicurezza	Anillo elastico	4
1940	1	2005805	Bearing, thrust	Axiallager	Palier axial	Cuscinetto assiale	Cojnete axial	2
1955	1	U2002700	Thrust washer kit	Druckscheibe	Rondelle de pousse	Rondella di spinta	Arandela de empuje	2
2100-0010	1	U2002218	Low/Int assy	Zahnrad Kriechgang/Mittel	Pignon vit.lente/int	Ingranaggio pmimo/int	Engranaje superoorta/int	1
2100-0040	2	2005442	Sensor	Sensor	Captur	Sensore	Sensor	4
2100-0050	2	X2014003	Circlip	Sicherungsring	Circlips	Anello di sicurezza	Anillo elastico	4
2100-0080	2	2005191	Ring, pre-energizer	Sensor-ring	Segment de pre-contrainte	Anello d'innesto	Anillo activante	4
2110	2	2005105	Sliding clutch	Schiebermuffe	Crabot	Mancotto scorrevole	Carrete	4
2120	1	2005091	Spring	Feder	Ressort	Molla	Muelle	2
2130	1	2005832	Snap ring	Sicherungsring	Circlips	Anello di sicurezza	Anillo elastico	2

Sequence No	Qty	Part No	English	Deutsch	Francais	Italiano	Espanol	Stock Qty
2200-0050-0010	1	2005262	Gear	Zahnrad	Pignon	Ingranaggio	Engranaje	2
2200-0050-0020	1	2005442	Sensor	Sensor	Capteur	Sensore	Sensor	4
2200-0050-0030	1	2005191	Ring pre-energiser	Sensor-ring	Segment de pre-contrainte	Anello d'innesto	Anillo activante	4
2200-0050-0040	1	X2014003	Circlip	Sicherungering	Circlips	Anello di sicurezza	Anillo elastico	4
			* Select to ensure correct gear end float	* Wählen für richtigen Axialspiel des Zahnrad	* Choisir pour assurer le jeu correct du pignon	* Scegliere per assicurare il Giuoco di accoppiamento corretto	* Escoger para el juego correcto del engranaje	

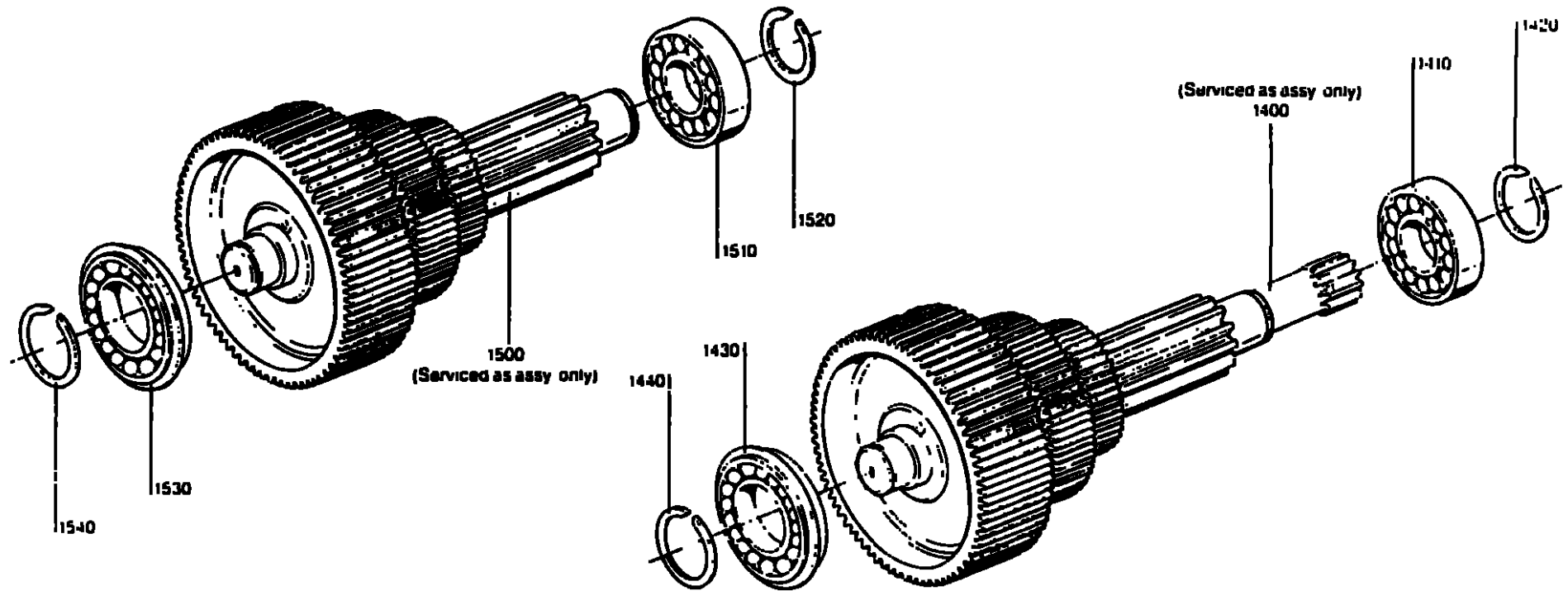

Front Countershaft Assembly, Vorgelegewelle, Arbre Secondaire Assemble, Contalbero Completo, Conjunto Eje Secundario

Sequence No	Qty	Part No	English	Deutsch	Francais	Italiano	Espanol	Stock Qty
1400	1	U2002708	Lower countershaft assy	Vorgelegewelle untere	Arbre secondaire inferieur	Contalbero inferiore	Eje secundario inferior	1
1500	1	U2002709	Upper countershaft assy	vorgelegewelle obere	Arbre secondaire superieur	Contalbero superiore	Eje secundario superior	1
1410) 1510)	2	14366	Roller bearing	Lager	Roulement	Cuscinetto	Cojinete	4
1420) 1520)	2	14317	Snap ring	Sicherungsring	Circlips	Anello di sicurezza	Anillo elastico	4
1430) 1530)	1	X2010016	Bearing	Lager	Roulement	Cuscinetto	Cojinete	2
1440) 1540)	1	X2014006	Snap ring, bearing, retaining	Sicherungsring	Circlips	Anello di sicurezza	Anillo elastico	2

Reverse Idler Gear, Rückwärtsgang-Umkehrad, Pignon de Renvol de Marche AR, Complessivo Ingranaggio, Rinvio Retromarcia, Engranaje Inversor MA

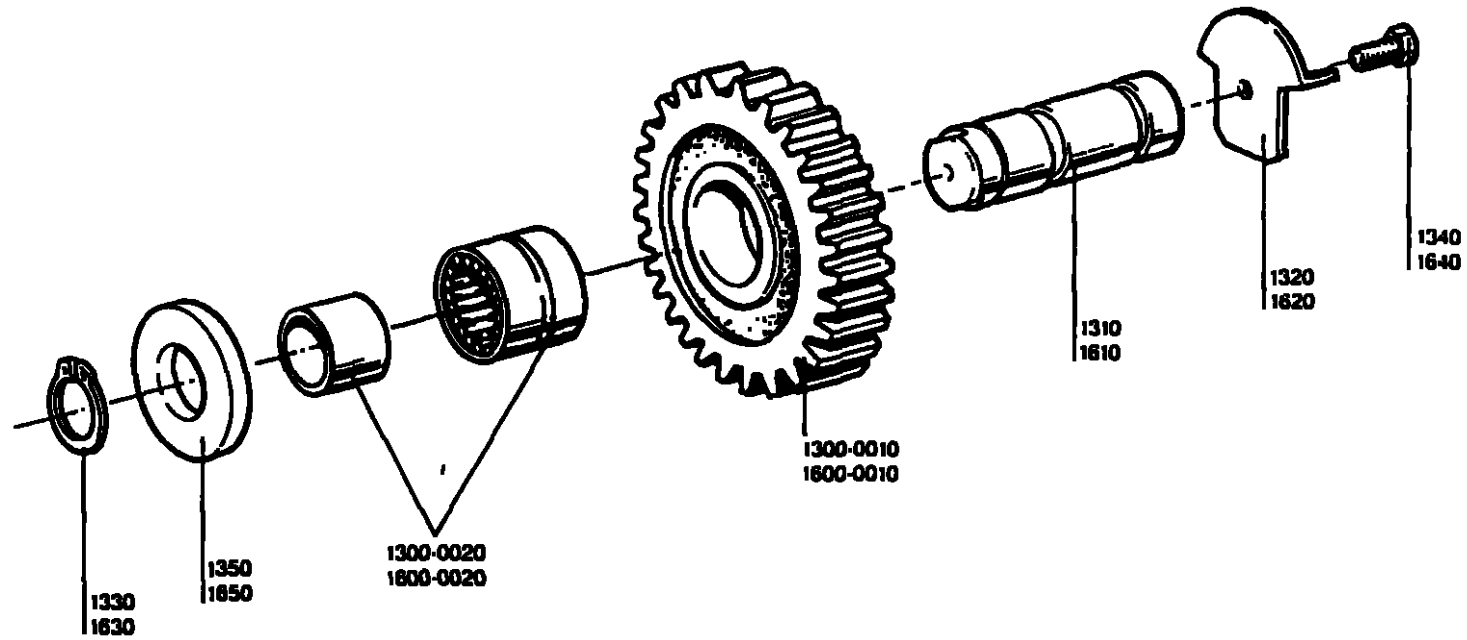

Reverse Idler Gear Assembly, Ruckwärtsgang-Unkehrtrad, pignon de Renvoi-Marche AR, Ingranaggio Rinvio Rm, Conjunto Inversor MA

Sequence No	Qty	Part No	English	Deutsch	Français	Italiano	Español	Stock Qty
1300	-	U2002308	Reverse idler gear assy	Ruckwärtsgang Unkehrtrad	Pignon de renvoi MA	Ingranaggio rinvio Rm	Conjunto inversor Ma	
1300-0010) 1600-0010)	2	2005884	Gear	Zahnrad	Pignon	Ingranaggio	Engranaje	4
1300-0020) 1600-0020)	2	X2010002	Needle bearing	Lager	Roulment	Cuscinetto	Cojnete	4
1310) 1610	2	2005052	Shaft	Welle	Axe	Albero	Eje	2
1320) 1620)	2	2005053	Washer	Scheibe	Rondelle	Rondella	Arandela	4
1330) 1640)	2	X2014001	Circlip	Sicherungsring	Circlips	Anello di sicurezza	Anillo elastico	4
1340) 1640)	2	X2011623	Screw M10 x 30	Schraube	Vvis	Vite	Tornillo	-
1350) 1650)	2	2005127	Washer	Scheibe	Rondelle	Rondella	Arandela	4

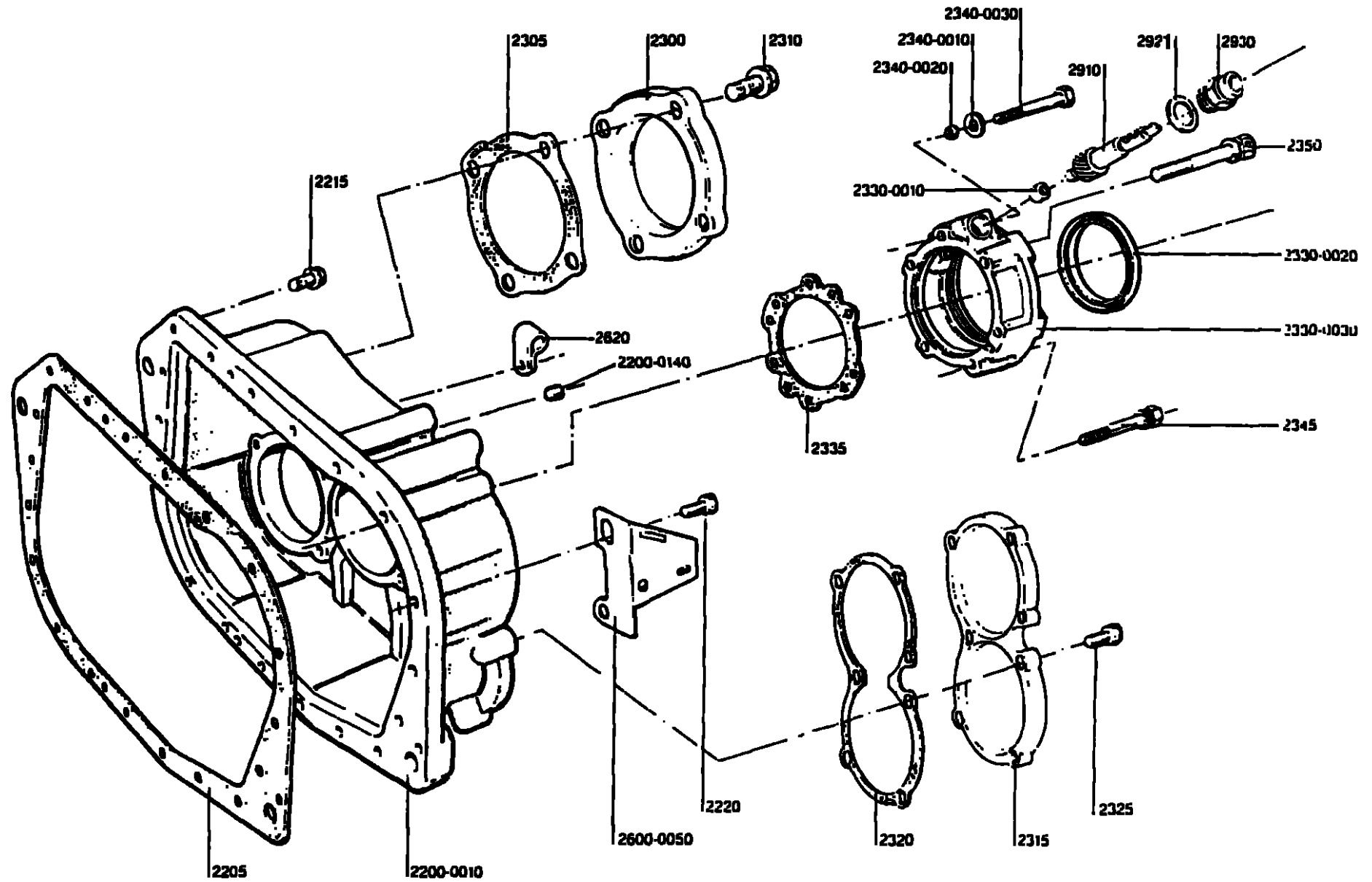

Filter Regulator Assembly, Filter/Regler Einheit, Filtre/Regulateur, Complessivo Filtro/Regolatore, Conjunto Filtro/Regulator

FILTER REGULATOR & BRACKET ASSEMBLY

2600

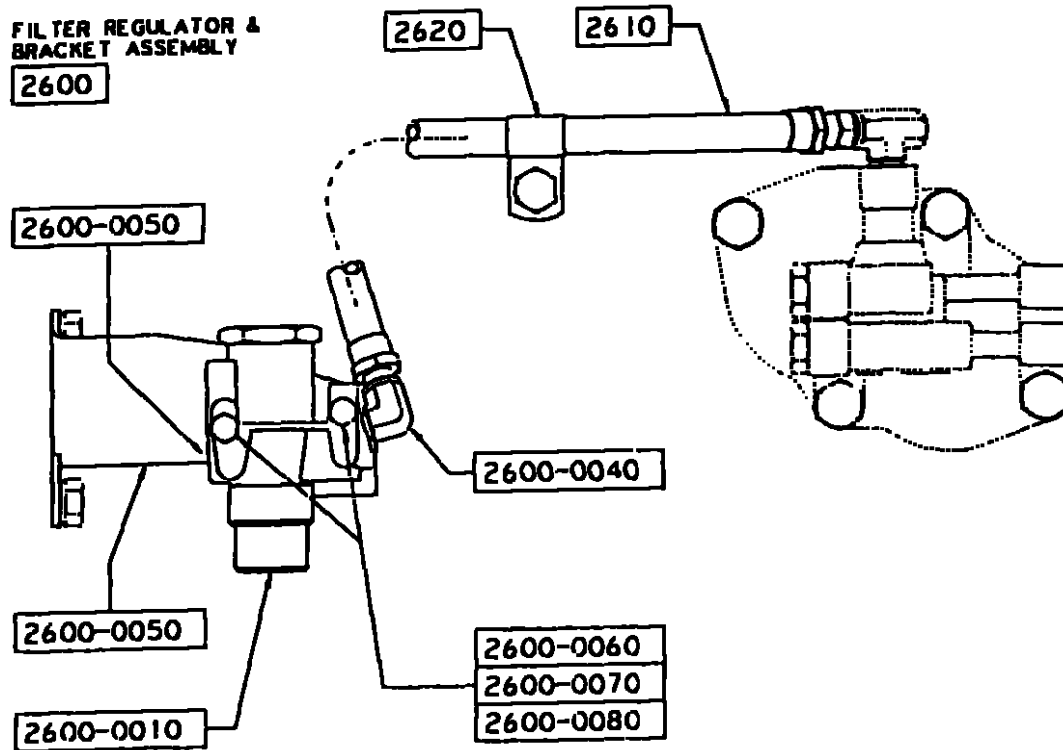

FILTER REGULATOR & BRACKET ASSEMBLY		
SEQUENCE No.	DESCRIPTION	QTY
2600 - 0010	FILTER REGULATOR	1
2600 - 0020	PIPE PLUG 1/8"NPTF	1
2600 - 0040	ELBOW 90 DEG.	1
2600 - 0050	BRACKET - AIR FILT. REG. ASSY	1
2600 - 0060	M6 SCREW & WASHER ASSY	2
2600 - 0070	WASHER - SPRING M6 TYPE B	2
2600 - 0080	NUT - HEX M6 x 10	2

REFERENCE PARTS LIST		
SEQUENCE No.	DESCRIPTION	QTY
2610	FLEXIBLE HOSE ASSY.	1
2620	CLAMP	1
2630	PULSE UNIT ASSY.	1
2640	SCREW M6 x 10 x 350	2
2650	BRACKET - AIR FILTER REGULATOR	1
2660	FLEXIBLE HOSE ASSEMBLY	1
2670	ELBOW 90 DEG.	1

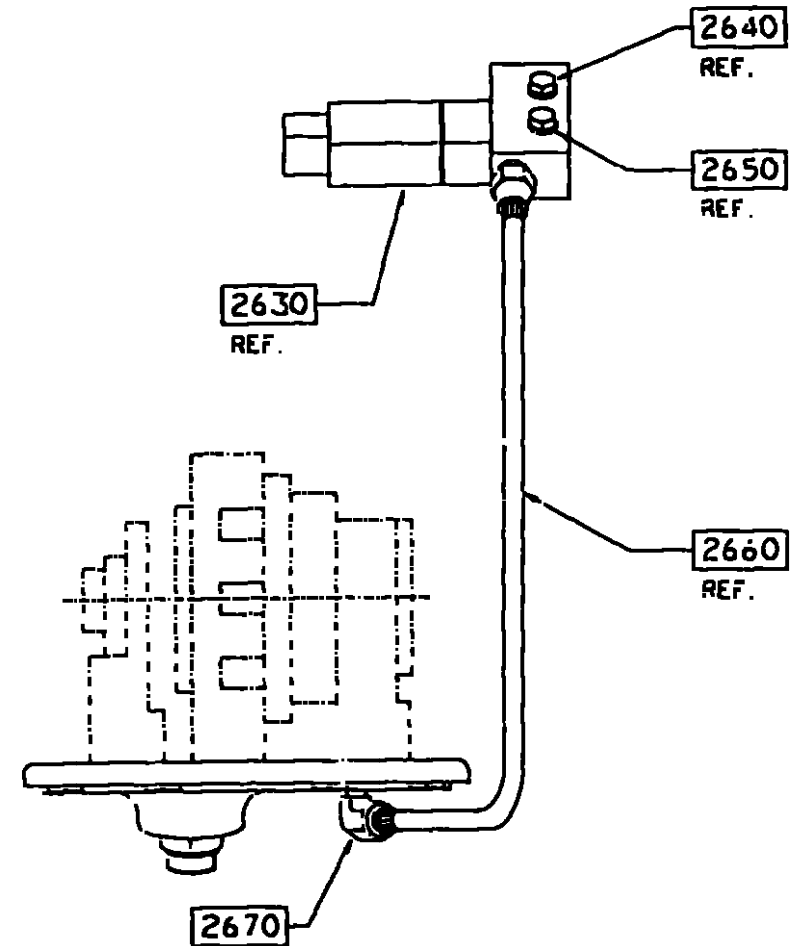

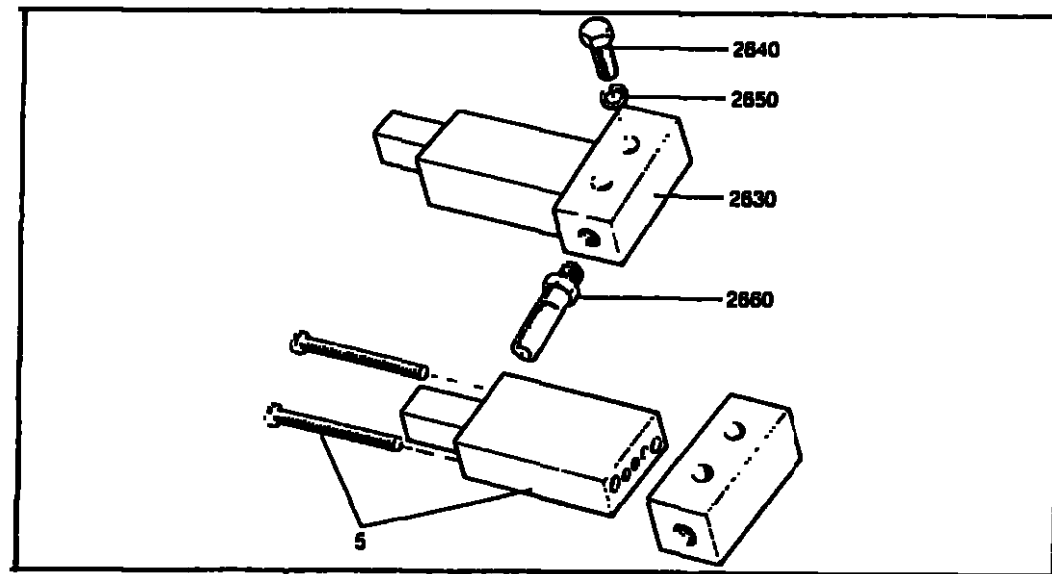
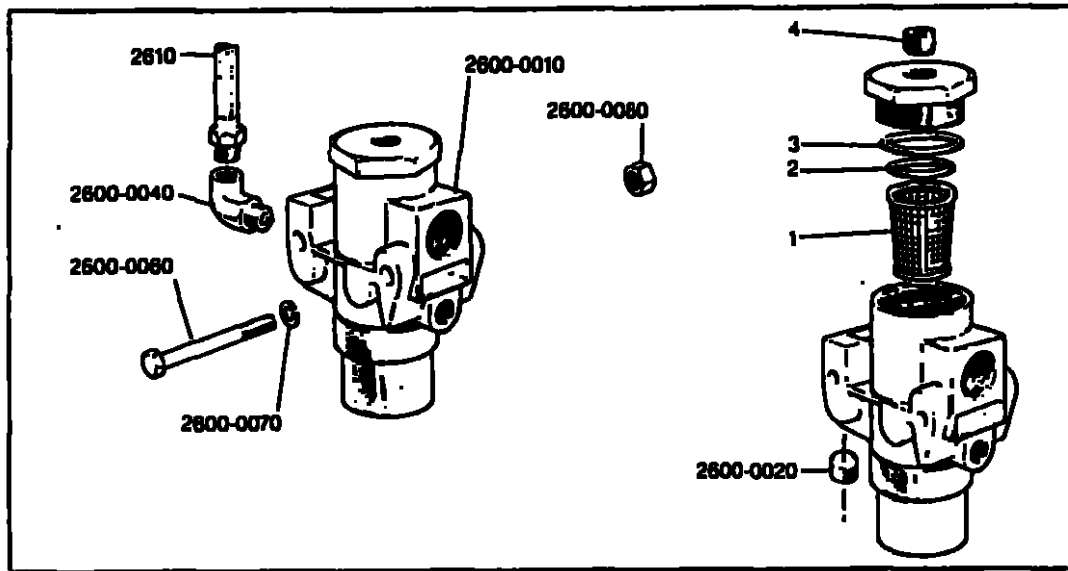

Rear Case Assembly, Nachschaltgruppen-Gehäuse, Carter Arriere Assemble, Complessivo Scatola posteriore, Conjunto Tapa Trasera

Sequence No	Qty	Part No	English	Deutsch	Francaise	Italiano	Espanol	Stock Qty
2200-0010	1	2006045	Housing	Gehäuse	Carter	Scatola	Carcasa Auxiliar	1
2200-0140	1	X2013515	Plug	Stopfen	Bouchon	Tappo	Tapon	-
2205	1	2005577	Gasket	Dichtung	Joint	Guarnizione	Junta	-
2215	17	X2011521	Screw/washer M10 x 38	Schraube/Federring	Vis/rondelle grower	Vite/rosetta	Tornillo/arandela	-
2220	2	X2011513	Screw/washer M10 x 50	Schraube/Federring	Vis/rondelle grower	Vite/rosetta	Tornillo/arandela	-
2230	0	85002	Connector					
2231	0	84002	Connector					
2235	1	21086	Tee 1/8	T-Stück	Element en T	Pezzo a T	Pieza en T	-
2305	1	17097	Gasket	Dichtung	Joint	Guarnizione	Junta	-
2300	1	2005148	Cover-aux c/shaft bry	Deckel	Couvercle	Coperchio	Tapa	-
2310	4	X11248	Screw M10 x 20	Schraube	vis	Vite	Tornillo	-
2315	1	2005048	Cover	Deckel	Couvercle	Coperchio	Tapa	-
2320	1	2005570	Gasket	Dichtung	Joint	Guarnizione	Junta	-
2325	7	X2011521	Screw/washer M10 x 38	Schraube/Federring	Vis/rondelle grower	Vite/rosetta	Tornillo/arandela	-
2330-0010	0		Bush	Buchse	Bague	Boccola	Casquillo	2
2330-0020	1	21036	Oil seal	Dichtung	Joint d'étanchéité	Paraulio	Rete	4
2330-0030	1	2005500	Speedo housing	Deckel, Tachometer	Couvercle, compteur de vitesse	Coperchio, tachimetro	Tapa, velocimetro	1
2335	1	2005146	Gasket	Dichtung	Joint	Guarnizione	Junta	-
2340-0010	0		Gasket	Dichtung	Joint	Guarnizione	Junta	-
2340-0020	0		Collar - seaking	Scheibe	Collier	Collanno	anillo	-
2340-0030	0		Screw	Schraube	Vis	Vite	Tornillo	-

2345	6	X11271	Bolt M10 x 75	Schraube	Vis	Vite	Tornillo	-
2350	1	X2011517	Screw/washer M10 x 75	Schraube/Federring	Vis/rondele grower	vite/rosetta	Tornillo/mandela	
2600-0010	1	2005128	Filter regulator	Filter/regler einheit	Filtre/regulateur	Complesivo filtro/regolatore	Conjunto filtro/regulator	
2600-0020	1	X2013517	Plug	Stopfen	Bouchon	Tappo	Tapon	-
2600-0040	1	12845	Elbow	Winkelverschraubung	Coude	Raccordo a gomita	Tubo acodado	-
2600-0050	1	2005024	Bracket	Halter	Support	Supporto	Soporte	-
2600-0060	2	X2011548	Bolt M6 x 55	Schraube	Boulon	Bullone	Perno	-
2600-0070	2	X2012501	Washer M6	Schiebe	Rondelle	Rosetta	Arandela	-
2600-0080	2	X2012003	Nut M6	Mutter	Ecrow	Dado	Tuerca	-
2610	1	56507	Hose	Schlauch	Flexible	Tubo flessibile	Tuberia	-
2620	1	11665	Clamp	Schelle	Collier	Fascetto	Arazadera	-
2630	1	2005020	Pulse unit assy					
2640	2	X2011508	Bolt M6 x 35	Schraube	Boulon	Bullone	Perno	-
2650	2	X2012501	Washer M6	Schraube	Rondelle	Rosetta	Arandela	-
2660	1	X2014106	Hose	Schlauch	Flexible	Tubo flessibile	Tuberia	-
2670	1	12845	Elbow	Winkelverschraubung	Coude	Raccordo a gomita	Tubo acodado	-

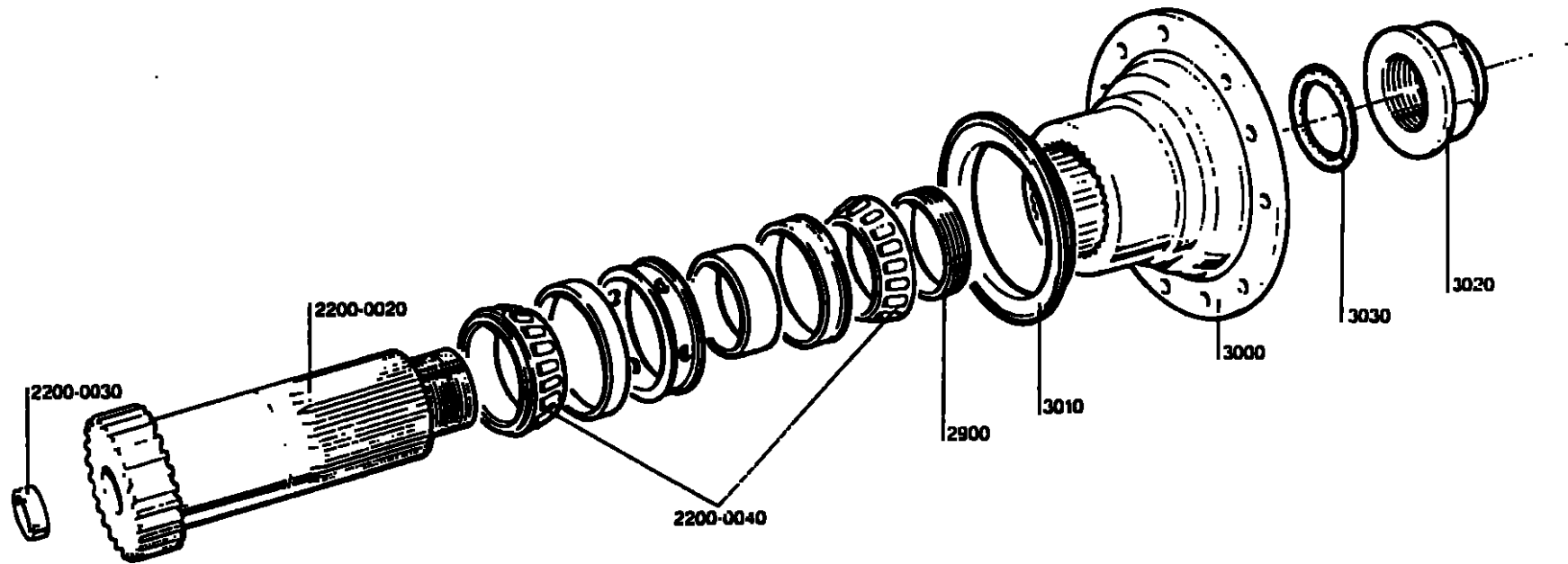

Output Shaft Assembly, Abtriebswelle, Arbre de Sortie, Albero di Uscita, Eja de Salida

Sequence No	Qty	Part No	English	Deutsch	Francais	Italiano	Espanol	Stock Qty
2200-0020	1	2005985	Output shaft	Abtriebswelle	Arbre de sortie	Albero di uscita	Eje de salida	1
2200-0030	1	2005207	Bush	Buchse	Bague	Boccola	Casquillo	2
2200-0040	1	15260	Taper roller bearing	Kegelrollenlager	Roulement a roul.conique	Cuscinetto	Cojinete rodillos conicos	2
2900	0	F98130	Speedo worm	Tachometer-Antriebsrad	Pignon d'entrainement du	Ingranaggio comando compteur de vitesse	Mecanismo del velocimetro tachimetro	1
	OR							
2900	1	F98130	Rotor	Rotor	Rotor	Rotor	Rotor	-
2921	1	F98083	Copper washer	Scheibe, Kupfer	Rondelle en cuivre	Rondelle in rame	Arandela de cobre	-
3000	1	F98255	Output drive flange	Abtriebswellenflansch	Bride de sortie	di trasmissione	Plato impulsor de salida	1
	OR							
3000	0	2005549	Yoke	Schaltgabel	Fourchette	Forcella	Horquilla	
3010	1	F98189	Grit shield	Schutzschild	Casse poussiere	Riparo pietrisco	Recogempurezas	1
3020	1	F98454	Flange nut	Konternutter	Ecrou	Dado di ritegno	Contratuercas	2
3030	1	F98252	Seal	O Ring	Joint torique	Guarnizione toroidale	Junta torica	3

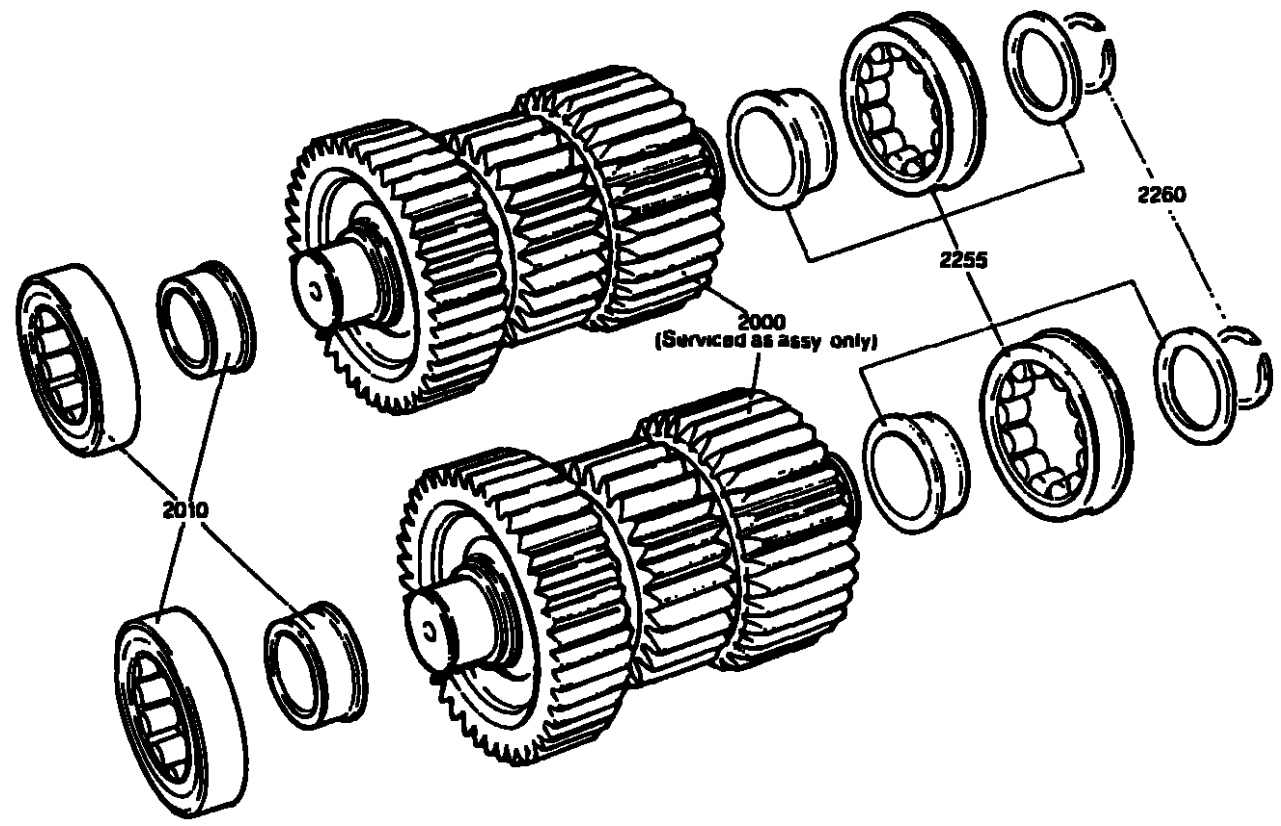

Auxiliary Countershaft Assy, Vorgelegewelle Nachschaltgruppe, Arbre Secondaire Auxiliaire, Contralbero Ausil Completo, Conjunto Eje Secundario Auxillar

Sequence No	Qty	Part No	English	Deutsch	Francais	Italiano	Espaniol	Stock Qty
2000	1	U2002813	Countershaft assembly	Vorgelegewelle	Arbre secondaire auxiliaire	Contralbero ausil completo	Conjunto eje secundario	1
2010	2	X2010027	Roller bearing	Lager	Roulement	Cuscinetto	Cojneta	4
2020	-	X11428	Loctite 601	Loctite 601	Loctite 601	Loctite 601	Loctite 601	-
2255	2	X11313	Bearing	Lager	Roulement	Cuscinetto	Cojneta	4
2260	2	X2014010	Snap ring	Sicherungsring	Circlips	Anello di sicurezza	Anillo elastico	4

Upshift Brake Assembly, Getriebebremse, Frein d'Inertie, Freno d'Inerzia, Freno de Cambios Hacia Arriba

For Serial Nos N 533587 and above.
 Ab Serienr. N 533587.
 Cette section indique les références suivantes: N 533587 et au dessus.
 Per i numeri di matricola fino a partire da N 533587.
 Para los números de serie: N 533587 y siguientes.

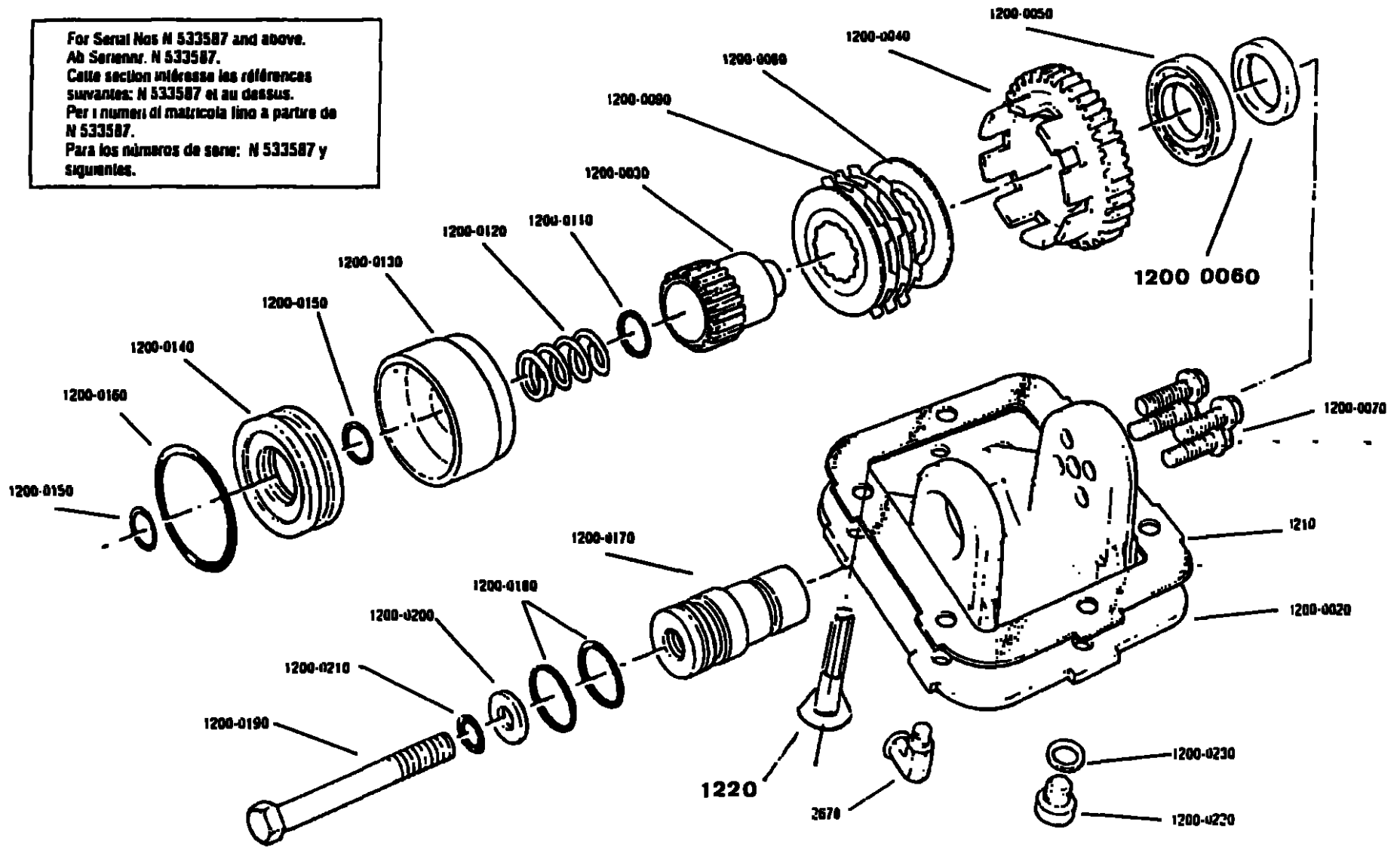

Upshift Brake Assembly, Getriebbremse, Frein d'Inertie, Freno d'inerzia, Freno de Cambios Hacia Arriba

Sequence No	Qty	Part No	English	Deutch	Francais	Italiano	Espanol	Stock Qty
1200	-	U2002337	Upshift brake assy	Getriebbremse	Frein d'inertie	Freno d'inerzia	Freno de cambios hacia arriba	
1200-0020	1	2005726	Housing	Deckel	Carter	Supporto	Envueta	
1200-0030	1	2005702	Splined shaft	Keilwelle	Axe cannale	Alberino scanalato	Eje estriado	
1200-0040	1	2005834	Gear	Zahnrad	Pignon	Ingranaggio	Engranaje	
1200-0050	1	X2010023	Bearing	Lager	Roulement	Cuscinetto	Copneta	
1200-0060	1	X2014160	Spacer	Distanzring	Entretoise	Distanziale	Separador	
1200-0070	4	X2011588	Bolt M8 x 30	Schraube	Boulons	Vite	Pasadores	
1200-0080	4	2005076	Friction disc - inner	Innere Bremscheibe	Disque de frein interne	Disco di attrito interno	Disco de friccion - interior	
1200-0090	3	2005077	Friction disc - outer	Außere Bremscheibe	Disque de frein externe	Disco di attrito esterno	Disco de friccion - exterior	
1200 0110	1	X2011035	O ring	O ring	Joint torque	Guarnizione O ring	Junta torica	
1200-0120	1	2005625	Spring	Druckfeder	Reasort	Molla	Muelle	
1200-0130	1	2005624	Pressure plate	Druckplatte	Plaque de pression	Springidisco	Placa de presion	
1200-0140	1	2005623	Piston	Kolben	Piston	Pistone	Piston	
1200-0150	2	X2011036	O ring	O ring	Joint torque	Guarnizione toroidale	Junta tori	
1200-0160	1	X2011037	O ring	O ring	Joint torique	Guarnizione toroidale	Junta torica	
1200-0170	1	2005701	Shaft	Welle	Axe	Albero	Eje	
1200-0180	2	X2011003	O ring	O ring	Joint torique	Guarnizione Toroidale	Junta torica	
1200-0190	1	MX-8-1015	Bolt M10 x 90	Schraube	Boulon	Vite	Esparrago	
1200-0200	1	X11245	Washer	Scheibe	Rondelle	Rondella	Arandela	
1200-0210	1	X2011034	O ring	O ring	Joint torque	Guarnizione toroidale	Junta torica	
1200-0220	1	X2013521	Drain plug	Ablassschraube	Bouchon de drainage	Tappo di scarico	Tapon de vaciado	
1200-0230	1	F96005	Washer	Scheibe	Rondelle	Rondella	Arandela	
1210	1	2005572	Gasket	Dichtung	Joint d'antanchaite	Guarnizione piana	Junta	
1220	6	X2011606	Csk screw M10 x 25	Schraube	Vis	Vite	Tornillo	
2670	1	12845	Elbow	Winkelverschraubung	Coude	Raccordo a gomita	Tubo acodado	

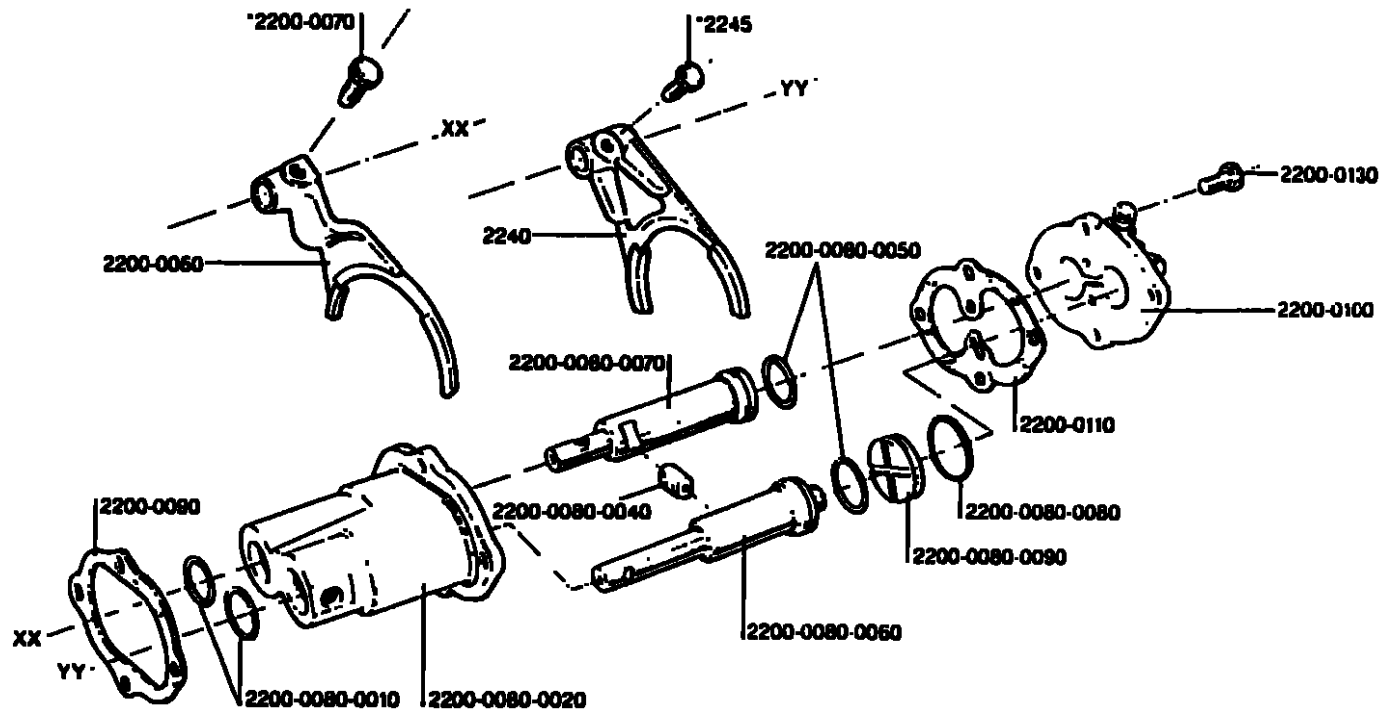

- * Use Lockwire.
- * Mit Draht sichern.
- * Utiliser fil de securité.
- * Usare filo bloccaggio.
- * Usar alambre de seguridad.

Splitter Cylinder Assembly, Splitter Zylinder, Cylindre du Relais, Servocilindro, Cilindro Splitter

Sequence No	Qty	Part No	English	Deutsch	Francés	Italiano	Español	Stock Qty
2200-0080	1	2005541	Yoke	Schaltgabel	Fourchette	Forcella	Horquilla	2
2200-0070	1	15778	Screw	Schraube	Vis	Vite	tornillo	-
2200-0080	-	U2002540	Aux shaft cylinder assy	Zylinder	Cylindre	Cilindro	Cilindro	-
2200-0080-0010	2	X2014174	Seal	Dichtung	Joint etancheite	Guarnizione tenuta	Reten	2
2200-0080-0020	1	2005979	Shift cylinder	Splitter zylinder	Cylindre du relais	Servo cilindro	Cilindro Splitter	1
2200-0080-0040	1	2005171	Pin	Sperrzapfen	Doligt de verrouillage	Nottolino di consenso	Pasador inestrobloqueo	2
2200-0080-0050	2	X2011008	O ring	O ring	joint torique	Guarnizione toroidale	Junta torica	6
2200-0080-0060	1	2005010	Piston	Kolben	Piston	Stantuffo	Piston	1
2200-0080-0070	1	2005173	Piston	Kolben	Piston	Stantuffo	Piston	1
2200-0080-0090	1	U2002815	Piston assy	Kolben	Piston	Stantuffo	Piston	1
2200-0080-0100	-	2008122	Silcon lubricant	Silikonschmierung	Lubrifiant au silicone	Lubrificante disiliconi	Silicona lubricante	1
2200-0090	1	2005573	Gasket	Dichtung	Joint	Guarnizione	Junta	2
2200-0100	1	2006405	Shift cover assy	Deckelgehäuse	Couvercle	Coparchio	Conjunto tapa	-
2200-0110	1	2005748	Gasket	Dichtung	Joint	Guarnizione	Junta	2
2200-0120	0	X2012504	Lockwasher	Federring	Rondelle grower	Rosetta elastica	Arandela elastica	-
2200-0130	4	MX-8-1018	Screw M10 x 40	Schraube	Vis	Vite	tornillo	-
2240	1	2005542	Yoke	Schaltgabel	Fourchette	Forcella	Horquilla	2
2245	1	15778	Screw	Schraube	vis	vite	Tornillo	-

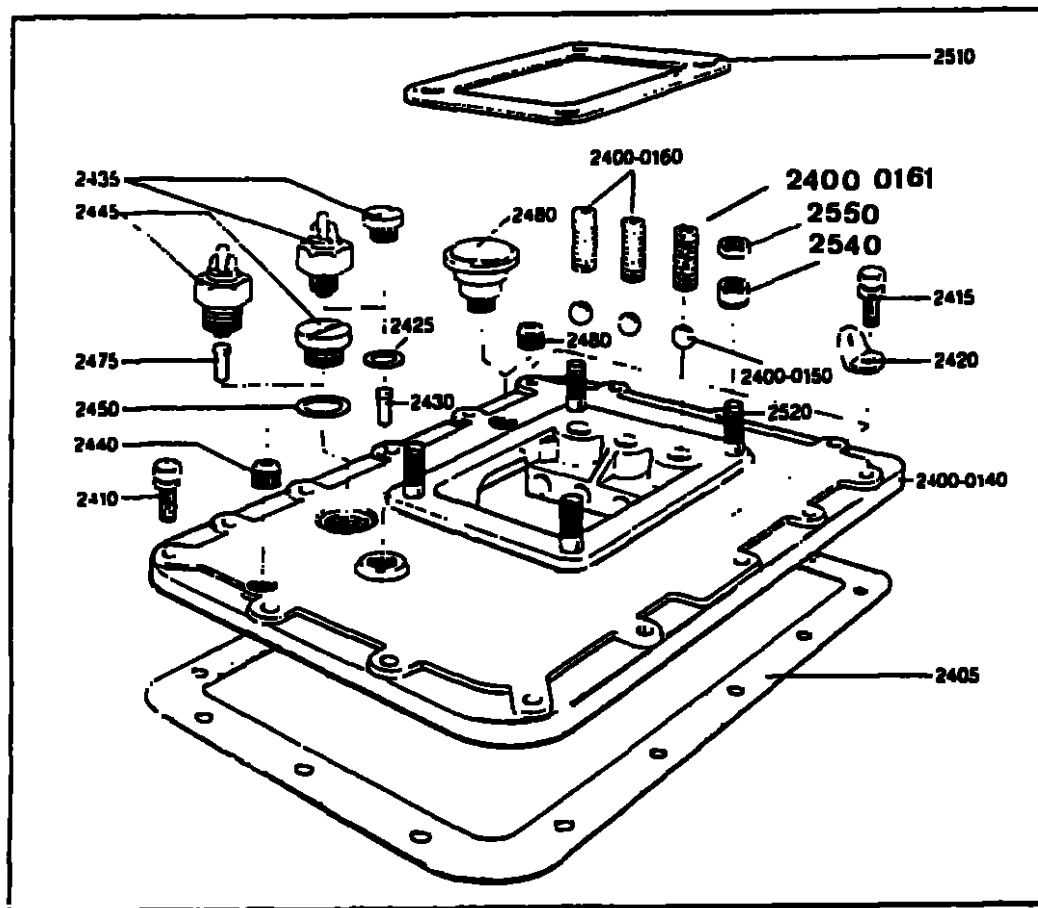

Yokes and Bars, Schaltgabeln und -schienen, Fourchettes et Barres, Forcelle Aste, Horquillas y Varillas

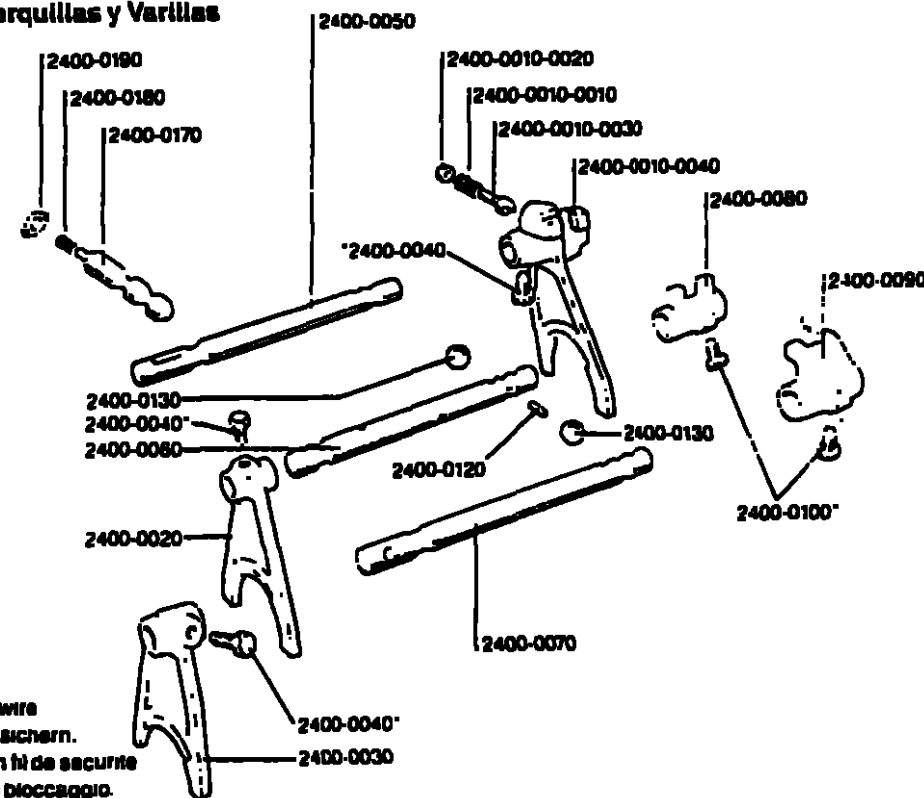

*Use Lockwire
*Mit Draht sichern.
*Utiliser un fil de securite
*Usare filo bloccaggio.
*Usar alambre de seguridad.

Shift Bar Housing Assembly, Schaltdeckel, Couvercle de Changement de Vitesse, Coperchio Selettore, Tapa de Varillas

Sequence No	Qty	Part No	English	Deutsch	Francais	Italiano	Espanol	Stock Qty
2400	-	U2002878	Shift bar housing assy	Schaltdeckel	Couvercle	Coperchio selettore	Tapa de varillas	
2400-0010-0010	1	8392	Spring	Feder	Ressort	Molla	Muelle	-
2400-0010-0020	1	8968	Plug	Stopfen	Bouchon	Tappo	Tapon	-
2400-0010-0030	1	10019	Shift detent plunger	Kolben	Verrouillage	Perno di reazione	Vastago	-
2400-0010-0040	1	2005231	Yoke, reverse	Schaltgabel Ruckwarts	Fourchette Marche AR	Forcella cambio-retomarcia	Horquilla MA	1
2400-0020	1	2005012	Yoke 1st & 2nd	Schaltgabel 1/2 Gang	Fourchette 1ere/2nde	Forcella 1a/2a	Horquilla 1a/2a	1
2400-0030	1	2005229	Yoke 3rd & 4th	Schaltgabel 3/4 Gang	Fourchette 3eme/dir	Forcella 3a/diretta	Horquilla 3a/4a	1
2400-0040	3	15776	Lock Screw	Arretierschraube	Vis de blocage	Vite	Tornillo	
2400-0041	3	1819	Lockwire	Draht	Fil de securite	Filo bloccaggio	Alambre de seguridad	-
2400-0050	1	2005118	Bar, reverse	Schaltachse R-Gang	Axe de fourchette marche AR	Selettore cambio-retromarcia	Varilla MA	-
2400-0060	1	2005124	Bar 1st & 2nd	Schaltachse 1/2 Gang	Axe de fourchette 1ere/2nde	Asta di comando 1a/2a	Varilla 1a/2a	-
2400-0070	1	2005800	Bar 3rd & 4th	Schaltachse 3/4 Gang	Axe de fourchette 3eme/dir	Asta di comando 3a/dir	Varilla 3a/4a	-
2400-0080	1	2005232	Block 1st & 2nd	Schaltblock 1/2 Gang	Selecteur 1ere/2nde	Nasello cambio 1a/2a	Selector 1a/2a	-
2400-0090	1	2005118	Block 3rd & 4th	Schaltblock 3/4 Gang	Selecteur 3eme/dir	Nasello cambio 3a/dir	Selector 3a/4a	-
2400-0100	2	15776	Lockscrew	Arretierschraube	Vis de blocage	Vite	Tornillo	-
2400-0120	1	1834	Pin	Stift	Goupille	Alberino	Pasador	-
2400-0130	2	X-14-1200	Ball 3/4"	Kugel	Bille	Sfera	Bola	3
2400-0140	1	2005592	Shift bar housing	Schaltdeckel	Couvercle de changement de vitesse	Coperchio selettore	Tapa de varillas	1
2400-0150	3	X-14-800	Ball 1/2"	Kugel	Bille	Sfera	Bola	3
2400-0160	2	2005019	Spring	Feder	Ressort	Molla	Muelle	2
2400-0161	1	F98084	Spring	Feder	Ressort	Molla	Muelle	1

Sequence No	Qty	Part No	English	Deutsch	Français	Italiano	Español	Stock Qty
2400-0170	1	2005725	Shaft neutral switch actuator	Betätigungskolben schalter für neutralstellung	Pionneur-contracteur de point mort	Otturatore di comando interruttore di folle	Vástago-activador interruptor neutro	-
2400-0180	1	2005017	Spring	Feder	Resort	Molla	Muelle	-
2400-0190	1	2005187	Plate	Platte	Plaque	Plastra	Placa	-
2405	1	2005578	Gasket	Dichtung	Joint	Guarnizione	Junta	-
2410	14	MX-8L-1017	Screw/washer M10 x 35	Schraube/Federring	Vis/rondelle	Vite/rosetta	Tornillo/arandela	-
2415	2	MX 8L-1019	Screw/washer M10 x 40	Schraube/Federring	Vis rondelle grower	Vite/rosetta	Tornillo/arandela	-
2420	2	20815	Lifting eye	Hebese	Patte de lavage	Anello di sollevamento	Place de izar	-
2425	1	15900	Gasket	dichtung	Joint	Guarnizione	Junta	-
2430	1	15899	Actuating pin	Stift	Goupille	Alberino	Pasador	-
2435	0	F96040	Reverse switch	Rückfahrshalter	Conducteur de marche AR	Interruttore retromarcia	Interr marcha atras	1
	OR							
2435	1	X2013514	Plug-rev.switch	Stopfen	Bouchon	Tappo	Tapon	-
2440	1	X2013516	Pipe plug	Verschlusschraube	Bouchon filete	Tappo filettato	Tapon	-
2446	0	F96041	Neutral switch	Neutralstellungshalter	Contacteur de point mort	Interruttore folle	Interruptor de punto muerto	1
	OR							
2445	1	X2013513	Plug	Stopfen	Bouchon	Tappo	Tapon	-
2446	0	X14178	Washer	Scheibe	Rondelle	Rosetta	Arandela	-
2450	1	17179	Gasket	Dichtung	Joint	Guarnizione	Junta	-
2475	0		Actuating pin	Stift	Goupille	Alberino	Pasador	-
2480	1	X2013515	Pipe plug	Verschlusschraube	Bouchon filete	Tappo filettato	Tapon	-
2500	1	U2002092	LRC assy LH	Fernschaltung	Commande a distance	Commandi esterni	Control remoto	-
2510	1	1642	Gasket, shift lever	Dichtung	Joint	Guarnizione	Junta	-
2520	4	X11261	Stud M10 x 30	Stiftschraube	Goujon	Pigioniero	Esparrago	-
2540	4	X11262	M10 conical nut	Mutter M10	Ecrou M10	Dado M10	Tuerca M10	-

Sequence No	Qty	Part No	English	Deutsch	Francais	Italiano	Espanol	Stock Qty
2550	4	X11263	M10 lock nut	Sicherungsmutter m10	Euro M10	Dado M10	Tuerca M10	

LRC Remote Control Assembly, Fernschaltung, Commande a Distance, Complessivo Commando a Distanza, Conjunto Control Remote

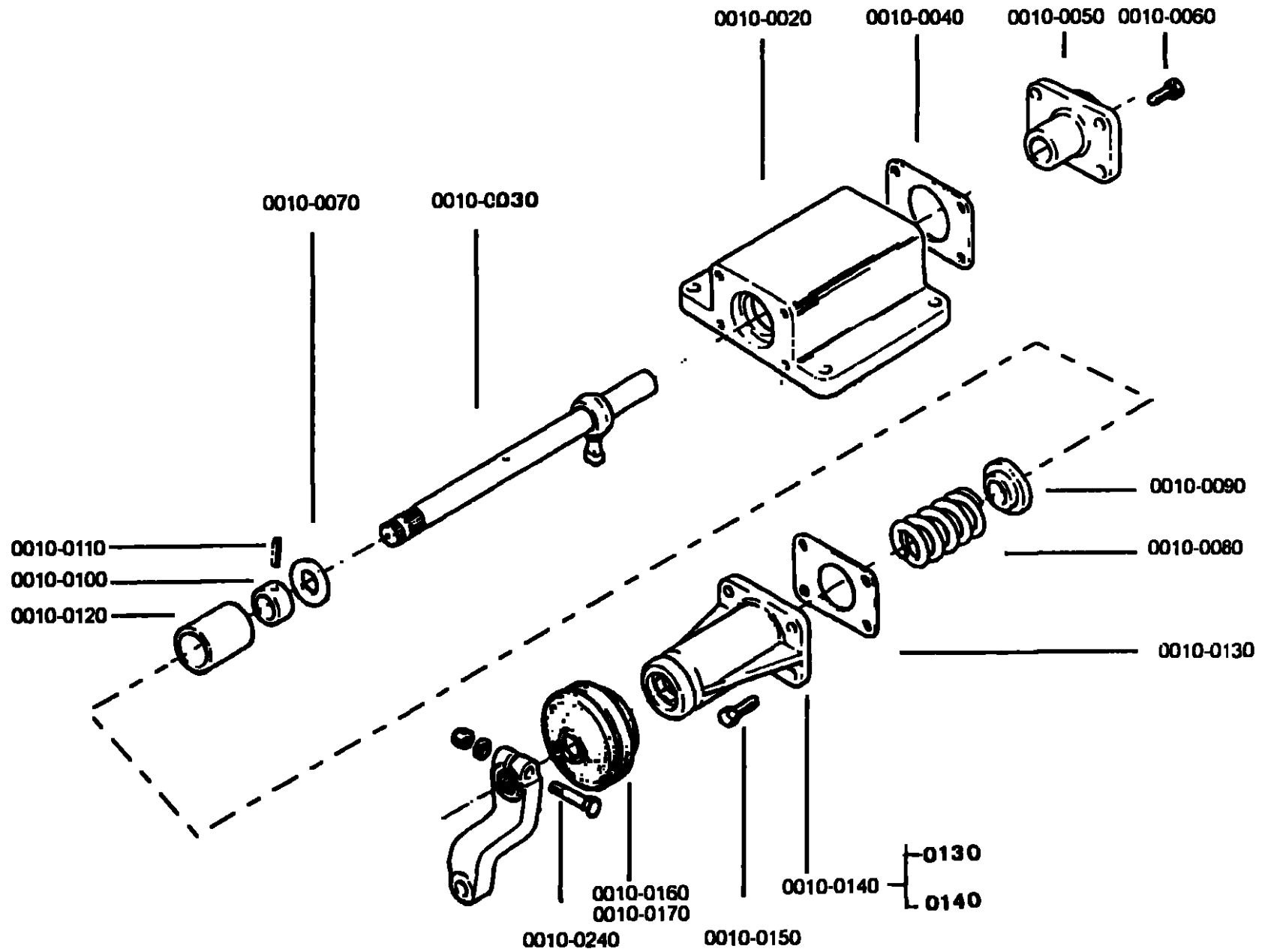

Control, Fernschaltung, Commande a Distance, Complessivo Commando, Conjunto Control Remoto

Sequence No	Qty	Part No	English	Deutch	Francais	Italiano	Espaniol	Stock Qty
2500	-	U2002082	LRC Assy - LHD	Fernschaltung	Commande a distance	Complessivo commando	Conjunto control remoto	-
2500-0010-0020	1	2005168	Housing Centre LRC	Gehäuse-	Corps-	Scatola-	Envuelta	-
2500-0010-0030	1	F93207	Cross shaft assy LRC	Schaltwelle	Axe	Albero trasversale	Eje	1
2500-0010-0040	1	F96457	Joint	Dichtung	Joint	Guarnizione	Junta	1
2500-0010-0050-1010	1	G36327	End cup	Deckel	Couvercle	Coperchio	Tapa	-
2500-0010 0050-1020	1	15313	Bushing	Buchse	Bague	Boccola	Casquillo	1
2500-0010-0060	4	X2011575	Bolt 5/16 UNC	Schraube	Boulon	Bullone	Perno	-
2500-0010-0070	1	F91135	Washer-spring retaining	Scheibe-	Rondelle-	Rosetta-	Arandela-	-
2500-0010-0080	1	F91138	Spring LRC	Feder	Ressort	Molla	Muelle	1
2500 0010-0090	1	F91154	Washer- stop	Scheibe-	Rondelle-	Rosetta-	Arandela-	-
2500-0010-0100	1	F91138	Collar LRC	Scheibe	Collet	Collarino	Anillo	-
2500-0010-0110	1	F91141	Spiral pin 3/16"	Stift	Goupille	Alberino	Pasador	-
2500-0010-0120	1	2005000	Sleeve-stop	Hülse-	Manchon-	Manicotto-	Casquillo-	-
2500-0010-0130	1	F96457	Joint	Dichtung	Joint	Guarnizione	Junta	1
2500-0010-0140-1030	1	G36328	Outer housing	Gehäuse-	Carter- exterieur	Scatola- esterne	Carcasa- exterior	-
2500-0010-0140-1040	1	15313	Bushing	Buchse	Bague	Boccola	Casquillo	1
2500-0010-0140-1050	1	F96181	Oil Seal	Oldichtung	Joint d'entancheite	Tenuta olio	Reten de aceite	1
2500-0010-0160	4	X2011575	Bolt 5/16" UNC	Schraube	Boulon	Bullone	Perno	-
2500-0010-0160	1	14975	Boot	Faltenblag	Manchon protecteur	Manicotto de gomma	Manila de acucho	1
2500 0010-0170	1	F96430	Cable tie	Kabelklammer	Attache-cable	Fissaggio del cavo	Sujetacable	-
2500-0240	1	X10256	Bolt 3/8" UNF x 2.00"	Schraube	Boulon	Bullone	Perno	-
2500-0270	1	23605	Breather	Entlüfter	Reniflard	Sfiatatoi	Respiro	-