

**EATON
TWIN SPLITTER
Illustrated Parts List**

**Ersatzteilleste
Catalogue Rechange
Catalogo Ricambi
Catálogo de Piezas de Recambio**

**IVECO
Y2000528
TS 13612A**

IVECO No 8868735

12/98

Section	English	Deutsch	Francaise	Italiano	Espanol	Section
1	Main Case Assy	Gehäuse Hauptgetriebe	Ensemble Carter Principal	Scatola Principale	Conjunto Carcasa Principal	1
2	Input Shaft Assy	Antriebswelle	Arbre D'Entree	Albero DI Entrata	Eje Primario	2
3	Mainshaft Assy	Hauptwelle	Arbre Principal Assemble	Albero Principale Completo	Conjunto Eje Principal	3
4	Front Countershaft Assy	Vorgelegewelle	Arbre Secondaire Assemble	Contraalbero Completo	Conjunto Eje Secundario	4
5	Reverse Idler Gear Assy	Ruckwärtsgang-Umkehrrad	Marche Arriere	Retro Marcia	Conjunto Inversor Ma	5
6	Rear Case Assy	Nachschaltgruppen-Gehäuse	Carter Arriere Assemble	Scatola Posteriore	Conjunto Tapa Trasera	6
7	Auxiliary Countershaft Assy	Vorgelewelle Nachschaltgruppe	Arbre Secondaire Auxiliare	Contraalbero Auxil Completo	Conjunto Eje Secundario Aux	7
9	Upshift Brake Assy	Getriebe Bremse	Frein D'Inertie	Freno D'Inerzia	Freno De Cambio Hacia Arriba	9
10	Splitter Cylinder	Splitter Zylinder	Cylindre Du Relais	Servo Cilindro	Cilindro Splitter	10
12	Shift Bar Housing Assy	Schaltdeckel	Couvercle de Changement de Vitesse	Coperchio Selettore	Tapa de Varillas	12
13	Remote Control Assy	Fernschaltung	Commande a distance	Complessivo comando a distanza	Conjunto control remoto	13

Section	English	Deutsch	Français	Italiano	Español	Section
Note	Stocking quantity shows recommended quantities for 25 transmissions	Lagerempfehlung für 25 Getriebe	Quantité de stockage pour 25 unités	Quantità per 25 cambi	Cant. stock para 25 cajas de cambio	
	# ORDER	# BESTELLEN	# COMMANDER	# ORDINAIRE	# PEDIR	

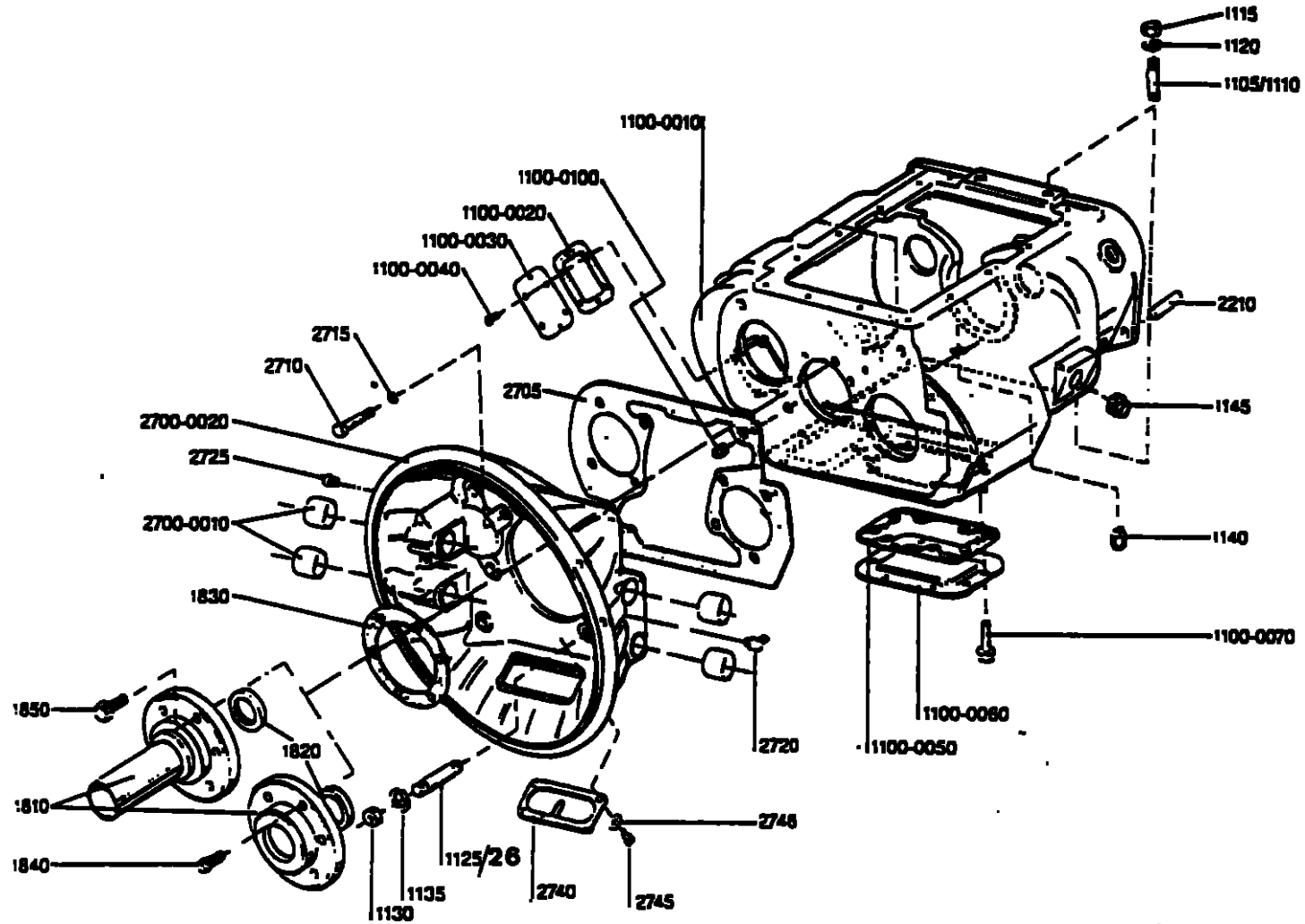

Main Case Assembly, Gehäuse Hauptgetriebe, Ensemble Carter Principal, Scatola Principale, Conjunto Principal
Section 1

Sequence No	Qty	Part No	English	Deutsch	Francés	Italiano	Español	Stock Qty
1100	Ref	U2002015	Maincase assy	-	-	-	-	-
1100-0010	1	2005247	Main Case	Gehäuse hauptgetriebe	Carter principal	Scatola principale	Carcasa principal	-
1100-0020	1	1884	Gasket	Dichtung	Joint	Guarnizione	Junta	1
1100-0030	1	2005144	Cover	Deckel	Couvercle	Coperchio	Tapa	-
1100-0040	6	X11248	Screw M10 x 20	Schraube	Vis	Vite	Tornillo	-
1100-0050	1	4302810	Gasket	Dichtung	Joint	Guarnizione	Junta	1
1100-0060	1	4302809	Cover	Deckel	Couvercle	Coperchio	Tapa	-
1100-0070	8	X2011547	Screw M12 x 28	Schraube	Vis	Vite	Tornillo	-
1100-0100	1	X-12-802	Plug 1/2	Stopfen	Bouchon	Tappo	Tapon	-
1105	2	X2014113	Stud M16 x 55.6	Stiftschraube	Goujon	Prigioniero	Esparrago	-
1110	0	X2014102	" " "		-	-	-	-
1115	2	X11618	Nut M16	Mutter	Ecrou	Dado	Tuerca	-
1120	2	X11617	Spring Washer M16	Federscheibe	Rondelle elastique	Rosetta elastica	Arandela elastica	-
1125	4	X2014101	Stud M16 x 62	Stiftschraube	Goujon	Prigioniero	Esparrago	-
1126	2	X2014123	Stud M16 x 140	Stiftschraube	Goujon	Prigioniero	Esparrago	-
1130	6	X2012002	Nut M16	Mutter	Ecrou	Dado	Tuerca	-
1135	6	X-10-1000	Washer	Federring	Rondelle grower	Rosetta elastica	Arandela elastica	-
1140	1	X14166	Magnetic drain plug	Verschlusschraube	Bouchon aimante	Tappo di scarico	Tapon magnetico	-
1145	1	X2013509	Filler plug	Einfallschraube	Bouchon rempl. d'huile	Tappo ramp. olio	Tapon	-
1810	1	2005472	Front bearing cover	Deckel	Couvercle de roulement	Coperchio cuscinetto	Tapa primario	1
1820	1	19111	Oil seal	Dichtung	Joint d'étanchéité	Para olio	Reten	2
1830	1	2005576	Gasket	Dichtung	Joint	Guarnizione	Junta	2
1840	4	X2011509	Screw M10 x 33	Schraube	Vis	Vite	Tornillo	-
1850	2	X2011514	Screw M10 x 33	Schraube	Vis	Vite	Tornillo	-

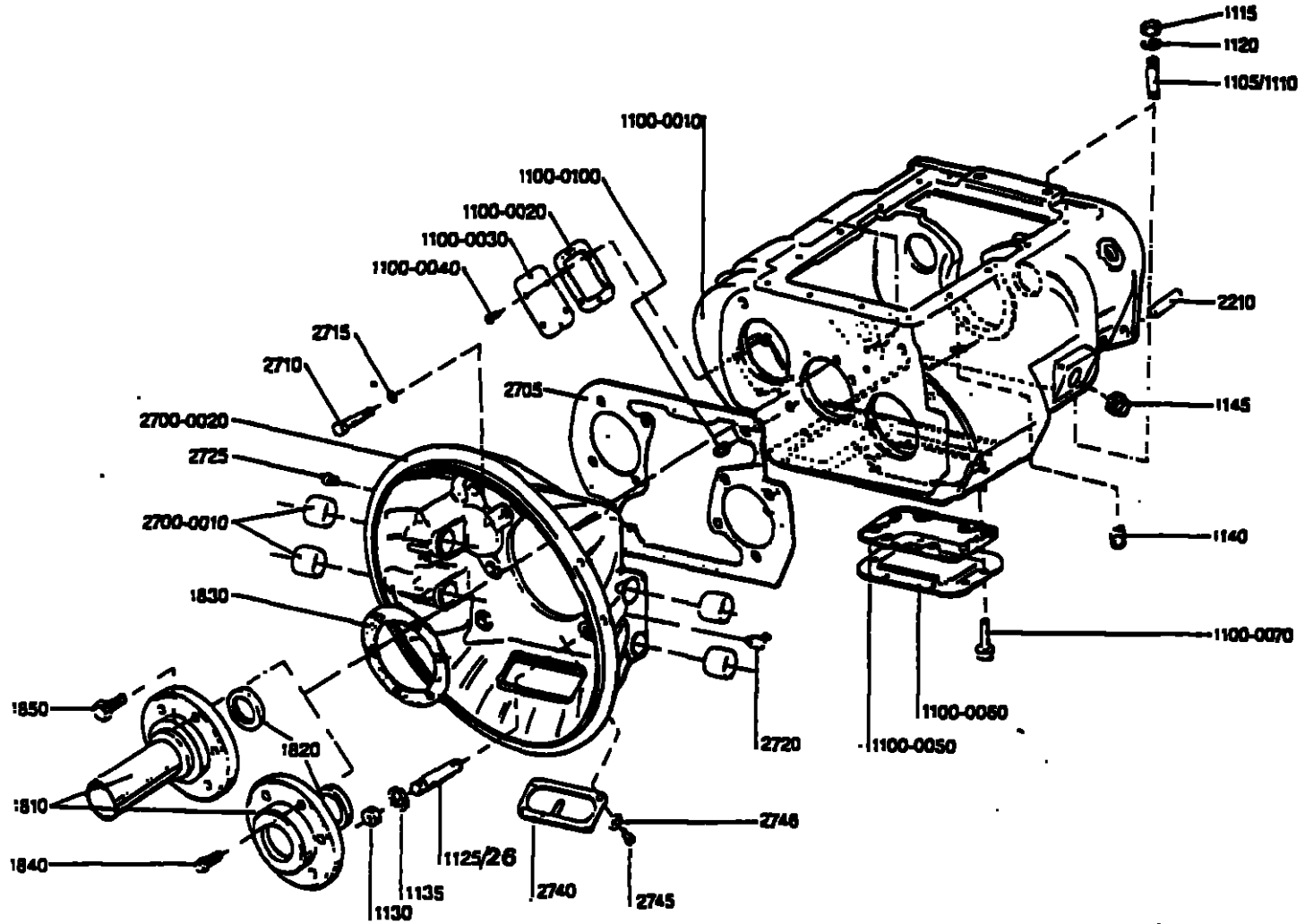

2210	2	14334	Dowel Pin	Passstift	Goupille	Spina centraggio	Espiga guia	-
2705	1	20822	Gasket	Dichtung	Joint	Guarnizione	Junta	-
2710	4	X2011510	Capcrew M12 x 40	Sechskantschraube	Vis	Vite	Tornillo	-
2715	4	X2012503	Lockwasher M12	Federring	Rondelle grower	Rosetta elastica	Arandela elastica	-
3220	0	MX-8-0805	Screw M6 x 16	Schraube	Vis	Vite	Tornillo	-
3230	0	MX-10-0801	Washer M8	Scheibe	Rondelle	Rosetta	Arandela	-
3240	0	2005485	Gasket-speed sensor	Dichtung-	Joint-	Guarnizione-	Junta-	1
3250	0	2005486	Cover-speed sensor	Deckel-	Couvercle-	Coperchio-	Tapa-	-

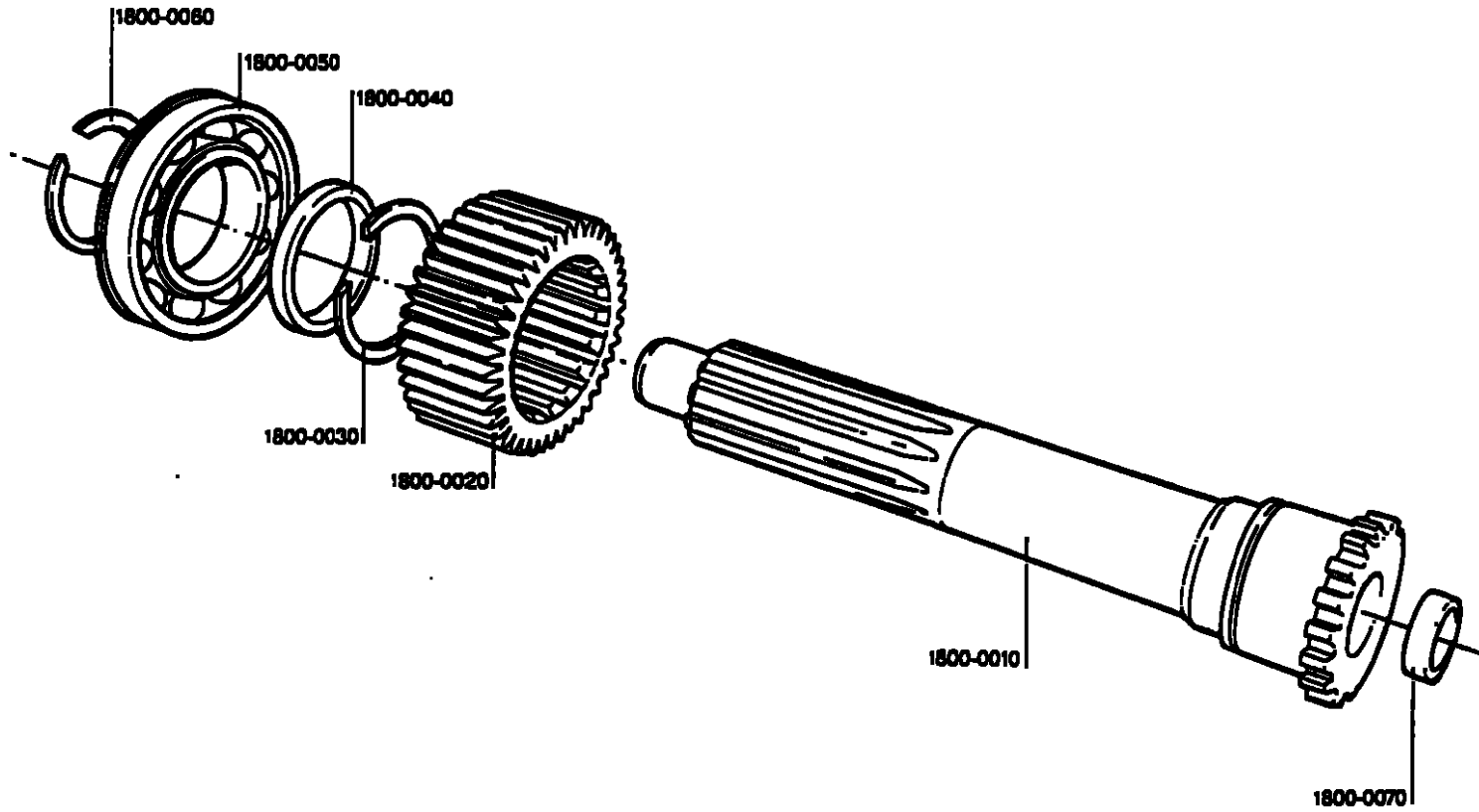

Input Shaft Assembly, Antriebswelle, Arbre d'Entree, Albero di Entrata, Eje Primario
Section 2

Sequence No	Qty	Part No	English	Deutsch	Francais	Italiano	Espanol	Stock Qty
1800	Ref	U2002571	Input shaft assembly	Abtriebswelle	Arbe d'entree	Albero entrata	Eje primario	1
1800-0010	1	2006000	Input shaft	Abtriebswelle	Arbe d'entree	Albero entrata	Eje primario	1
1800-0020	1	2005461	Drive Gear	Antriebsrad	Pignon d'entree	Ruoto dentata	Engranaje conductor	1
1800-0030	1	14289	Snap ring	Sicherungsring	Circlips	Anello di sicurezza	Anillo elastico	2
1800-0040	1	16396	Spacer	Distanzscheibe	Entretoise	Anello distanziale	Espaciador	-
1800-0050	1	81504	Ball bearing	Lager	Roulement	Cuscinetto	Cojnete	2
1800-0060	1	16980	Snap ring	Sicherungsring	Circlips	Anello di sicurezza	Anillo elastico	2
1800-0070	1	2005606	Bush	Busche	Bague	Boccola	Casquillo	2

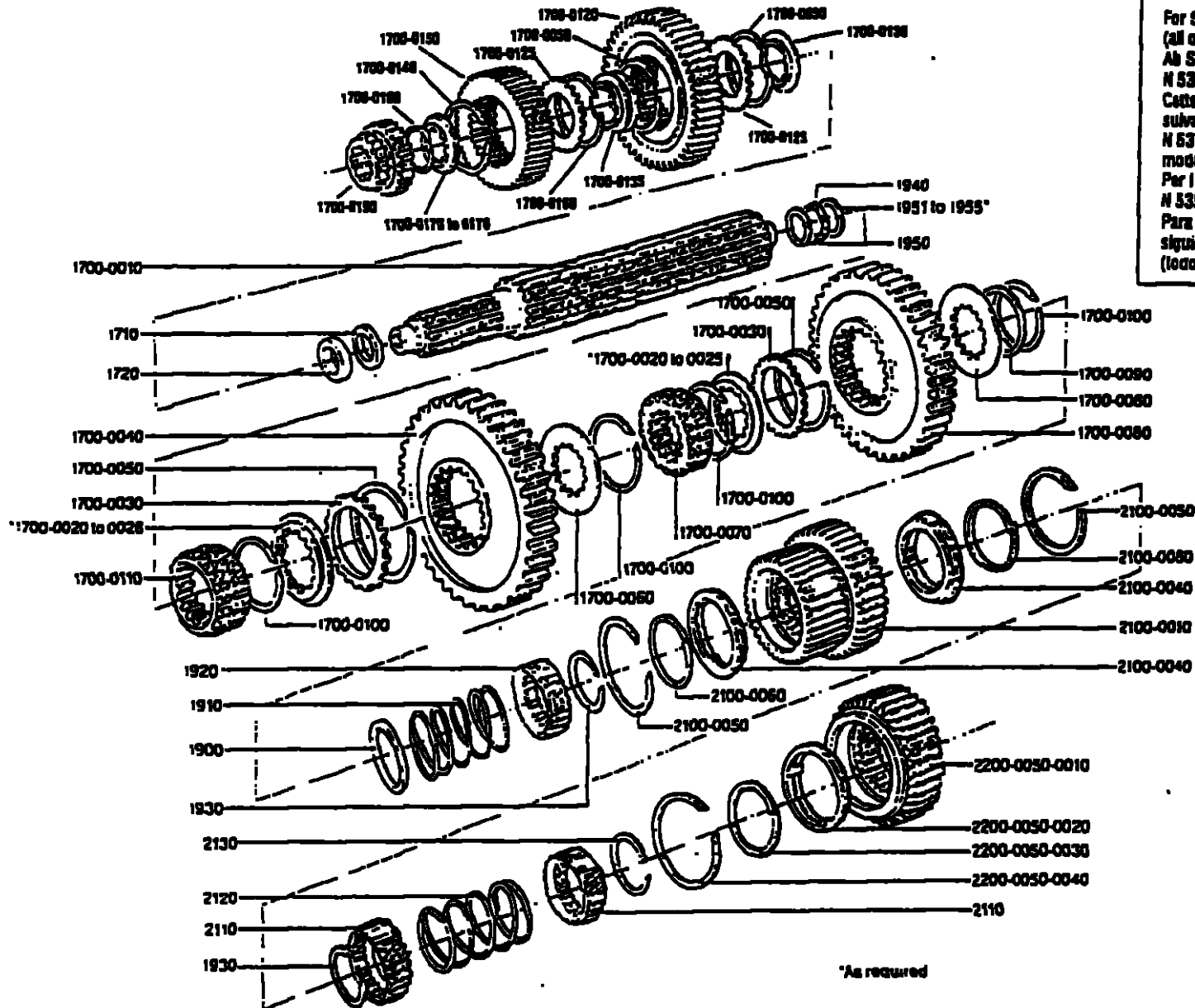

For Serial Nos N 535712 (ERF), N 537125 (all others) and above.
Ab Serienr. N 535712 (ERF) und ab N 537125 (alle anderen Modelle).
Cette section intresse les références suivantes: N 535712 et au dessus (ERF), N 537125 et au dessus (tous les autres modèles).
Per i numeri di matricola fino a partire da N 535712 (ERF), e N 537125 (altri modelli).
Para los números de serie: N 535712 y siguientes (ERF), N 537125 y siguientes (todos los restantes modelos)

Mainshaft Assembly, Hauptwelle, Arbre Principal Assemble, Albero Principale Completo, Conjunto Eje Principal

Section 3

Sequence No	Qty	Part No	English	Deutsch	Francais	Italiano	Espaniol	Stock Qty
1700	Ref	U2002658	Mainshaft Assembly	Hauptwelle	Arbre principal	Albero principale	Eje principal	1
1700-0010	1	2008051	Mainshaft	Hauptwelle	Arbre principal	Albero principale	Eje principal	1
1700-0020*	2	19911	Washer (6.30-6.35mm)	Distanzscheibe	Rondelle	Rondella	Arandela	3
1700-0020*	OR	19912	Washer (6.43-6.48mm)	Distanzscheibe	Rondelle	Rondella	Arandela	3
1700-0022*	OR	19913	Washer (6.55-6.60mm)	Distanzscheibe	Rondelle	Rondella	Arandela	3
1700-0023*	OR	19914	Washer (6.68-6.73mm)	Distanzscheibe	Rondelle	Rondella	Arandela	3
1700-0024*	OR	19915	Washer (6.80-6.86mm)	Distanzscheibe	Rondelle	Rondella	Arandela	3
1700-0025*	OR	19916	Washer (6.93-6.99mm)	Distanzscheibe	Rondelle	Rondella	Arandela	3
1700-0026*	OR	20011	Washer (6.22-6.17mm)	Distanzscheibe	Rondelle	Rondella	Arandela	3
1700-0030	2	4303199	Spacer-splined	Distanzscheibe	Entretoise	Anello distanziale	Espaciador	3
1700-0040	1	2005252	Gear 1st	Zahnrad 1- Gang	Pignon 1 ere	Ingranaggio 1a	Engranaje 1a	2
1700-0050	3	16798	Snap ring	Sicherungsring	Circlips	Anello di sicurezza	Anillo elastico	3
1700-0080	2	2005163	Washer	Scheibe	Rondelle	Rondella	Arandela	2
1700-0070	1	2005197	Sliding clutch	Schiebemuffe	Crabot	Manicotto scorrevole	Carreta	3
1700-0080	1	2005253	Gear rev	Zahnrad R-Gang	Pignon Marche Ar	Ingranaggio retromarcia	Engranaje MA	3
1700-0090	1	2005198	Washer	Scheibe	Rondelle	Rondella	Arandela	3
1700-0100	4	X2014022	Snap ring	Sicherungsring	Circlips	Anello di sicurezza	Anillo elastico	4
1700-0110	1	2005492	Sliding clutch	Schiebemuffe	Crabot	Manicotto scorrevole	Carreta	3
1700-0120	1	2005903	Gear 2nd	Zahnrad 2-Gang	Pignon 2eme	Ingranaggio 2a	Engranaje 2a	2
1700-0125	2	2005901	Spacer	Distanzscheibe	Entretoise	Anello distanziale	Espaciador	3
1700-0130	1	2005912	Spacer	Distanzscheibe	Entretoise	Anello distanziale	Espaciador	3
1700-0135	1	2005989	Spacer	Distanzscheibe	Entretoise	Anello distanziale	Espaciador	3
1700-0140	1	16798	Snap ring	Sicherungsring	Circlips	Anello di sicurezza	Anillo elastico	3
1700-0150	1	2005996	Gear 3rd	Zahnrad 3-Gang	Pignon 3eme	Ingranaggio 3a	Engranaje 3a	2
1700-0160	1	16798	Snap ring	Sicherungsring	Circlips	Anello di sicurezza	Anillo elastico	3

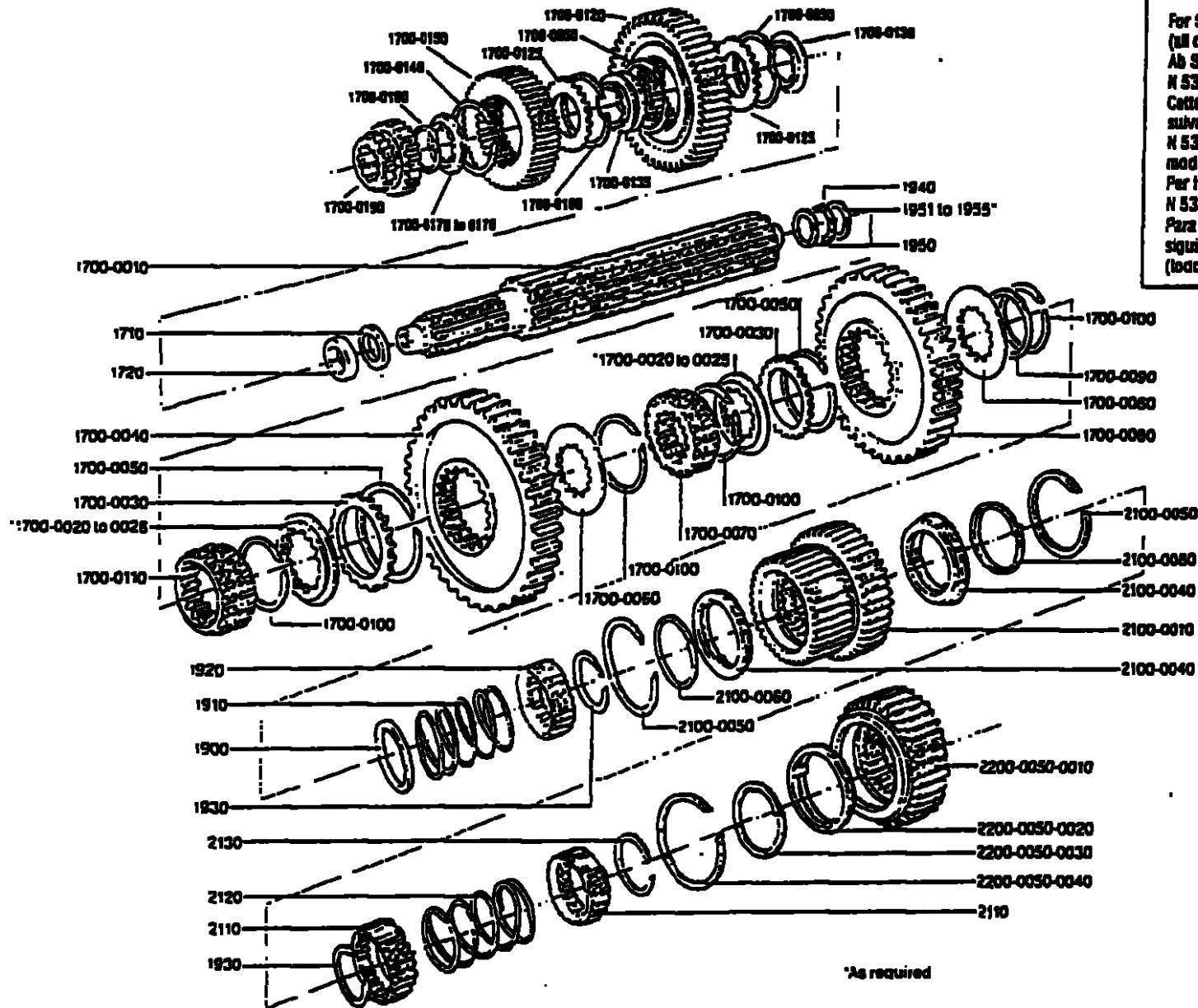

For Serial Nos N 535712 (ERF), N 537125 (all others) and above.
 Ab Serienr. N 535712 (ERF) und ab N 537125 (alle anderen Modelle).
 Cette section intresse les références suivantes: N 535712 et au dessus (ERF), N 537125 et au dessus (tous les autres modèles).
 Per i numeri di matricola (fino a partir de N 535712 (ERF), e N 537125 (altri modelli)).
 Para los números de serie: N 535712 y siguientes (ERF), N 537125 y siguientes (todos los restantes modelos)

Sequence No	Qty	Part No	English	Deutsch	Francais	Italiano	Espaniol	Stock Qty
1700-0169	1	2005918	Washer	Distanzscheibe	Rondelle	Rondella	Arandela	2
1700-0170*	1	2005919	Washer	Distanzscheibe	Rondelle	Rondella	Arandela	2
1700-0171*	OR	2005920	Washer	Distanzscheibe	Rondelle	Rondella	Arandela	2
1700-0172*	OR	2008043	Washer	Distanzscheibe	Rondelle	Rondella	Arandela	2
1700-0173*	OR	2005921	Washer	Distanzscheibe	Rondelle	Rondella	Arandela	2
1700-0174*	OR	2005922	Washer	Distanzscheibe	Rondelle	Rondella	Arandel	2
1700-0175*	OR	2005923	Washer	Distanzscheibe	Rondelle	Rondella	Arandela	2
1700-0178*	OR	2005924	Washer	Distanzscheibe	Rondelle	Rondella	Arandela	2
1700-0178*	OR	2008043	Washer	Distanzscheibe	Rondelle	Rondella	Arandela	2
1700-0180	1	18723	Snap ring	Sicherungsring	Circlips	Anello di sicurezza	Anillo elastico	
1700-0190	1	2005909	Sliding clutch 3/4	Schiebemuffe	Crabot	Manicotto scorrevole	Carrete	3
1710	1	2005805	Thrust washer	Druckscheibe	Rondelle de pousse	Rondella di spinta	Arandela de empuje	2
1720	1	2005730	Thrust washer	Druckscheibe	Rondelle de pousse	Rondella di spinta	Arandela de empuje	4
1900	1	2005093	Retainer	Stutzscheibe	Bague de retenue	Anello di ritagno	anillo apoyo	1
1910	1	2005091	Spring	Feder	Ressort	Molla	Muelle2	
1920	1	2005105	Sliding clutch	Schiebemuffe	Crabot	Manicotto scorrevole	Carrete	2
1930	2	2005832	Snap ring	Sicherungsring	Circlips	Anello di sicurezza	Anillo elastico	4
1940	1	2005805	Bearing, thrust	Axiallager	Paller axial	Cuscinetto assiale	Cojinete axial	2
1955	1	U2002700	Thrust washer kit	Druckscheibe	Rondelle de pousse	Rondella di spinta	Arandela de empuje	2
2100-0010	1	U2002219	Low/direct cluster gear assy	Zahnrad Kriechgang/direkt	Pignon vit.lente/directe	Ingranaggio primino/diretto	Engranaje supercorta/directo	-
2100-0040	2	2005442	Sensor	Sensor	Captur	Sensore	Sensor	4
2100-0050	2	X2014003	Circlip	Sicherungsring	Circlips	Anello di sicurezza	Anillo elastico	4
2100-0080	2	2008311	Ring, pre-energiser	Sensor-ring	Segment de pre-contrainte	Anello d'innesto	Anillo activante	4

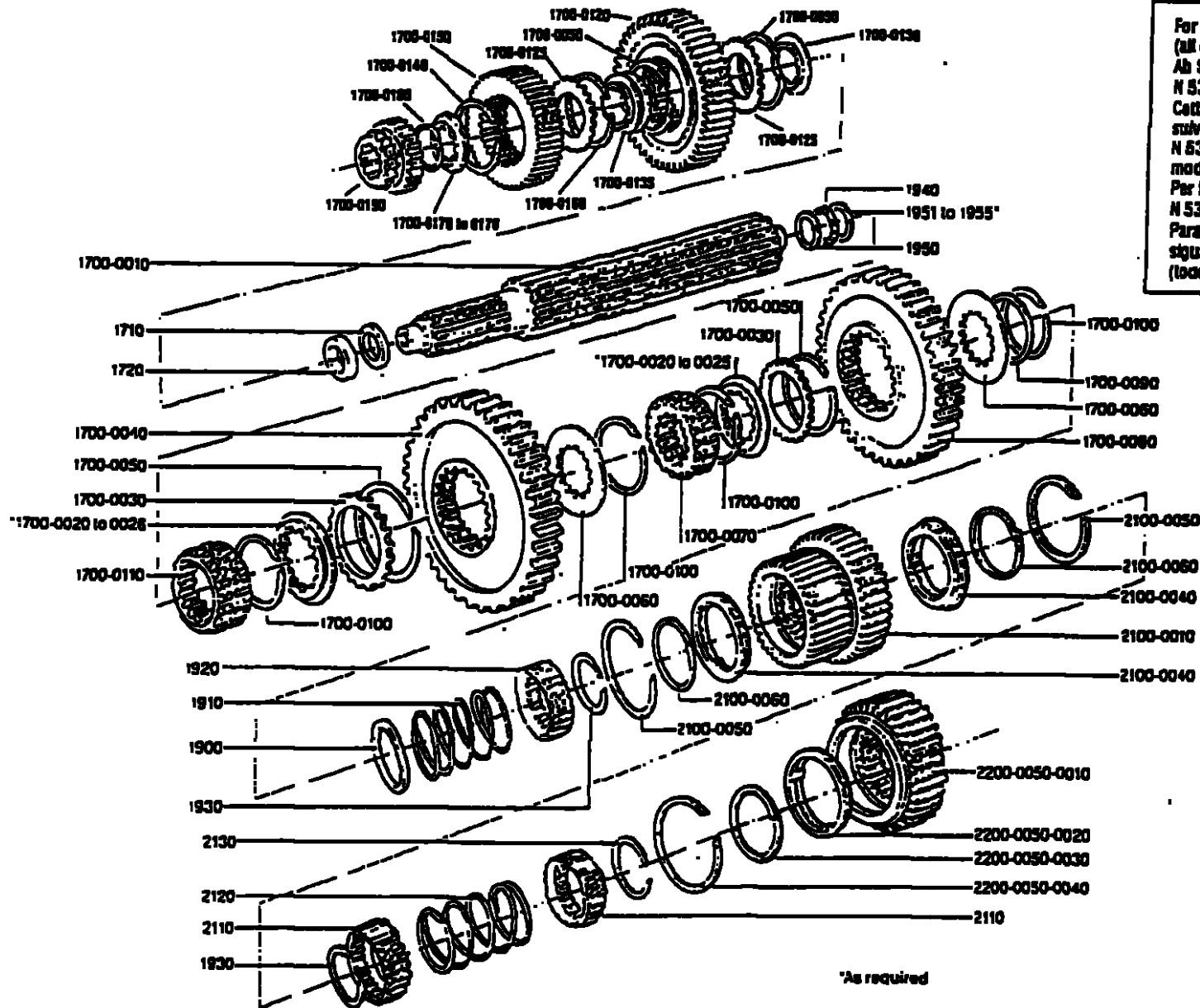

For Serial Nos N 535712 (ERF), N 537125 (all others) and above.
 Ab Serienr. N 535712 (ERF) und ab N 537125 (alle anderen Modelle).
 Cette section interesse les references suivantes: N 535712 et au dessus (ERF), N 537125 et au dessus (tous les autres modes).
 Per i numeri di matricola fino a partire de N 535712 (ERF), e N 537125 (altri modelli).
 Para los números de serie: N 535712 y siguientes (ERF), N 537125 y siguientes (todos los restantes modelos)

*As required

Sequence No	Qty	Part No	English	Deutsch	Francais	Italiano	Espaniol	Stock Qty
2110	2	2005105	Sliding clutch	Schiebmuffe	Crabot	Manicotto scorrevole	Carrete	4
2120	1	2005092	Spring	Feder	Ressort	Molla	Muelle	2
2130	1	2005832	Snap ring	Sicherungsring	Circlips	Anello di sicurezza	Anillo elastico	2
2200-0050-0010	1	2005282	Gear-aux.mainshaft direct	Zahnrad- vorgelehauptwelle, direkt	Pignon-arbre principal secondaire, directe	Ingranaggio-albero principale ausil, diretto	Engranaje-eje principal secundario, directo	-
2200-0050-0020	1	2005442	Sensor	Sensor	Capteur	Sensore	Sensor	4
2200-0050-0030	1	2006311	Ring pre-energiser	Sensor-ring	Segment de pre- contrainte	Anello d'innesto	Anillo activante	4
2200-0050-0040	1	X2014003	Circlip	Sicherungsring	Circlips	Anello di sicurezza	Anillo elastico	4
			* Select to ensure correct gear end float	* Wahlen für richtigen Axialspiel des Zahnrads	* Choisir pour assurer le jeu correct du pignon	* Scegliere per assicurare il Giuoco di accoppiamento corretto	* Escoger para el juego correcto del engranaje	

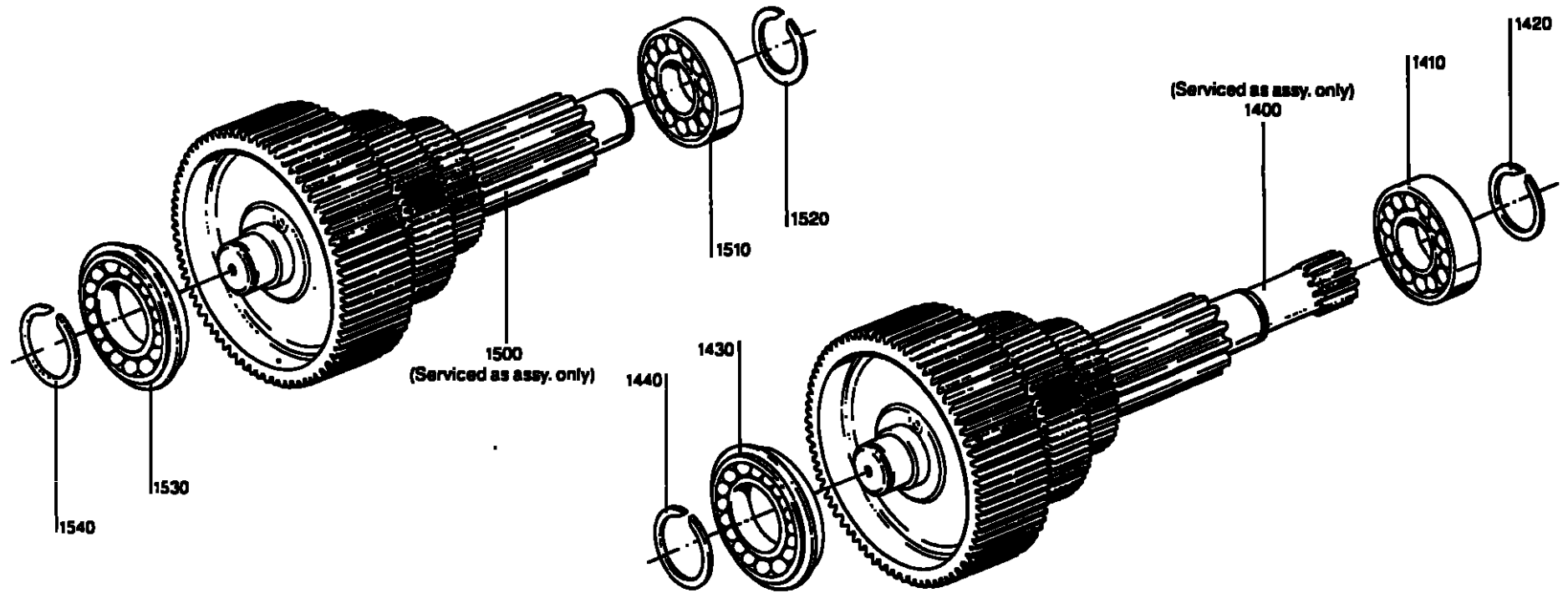

Front Countershaft Assembly, Vorgelegewelle, Arbre Secondaire Assemble, Contalbero Completo, Conjunto Eje Secundario
Section 4

Sequence No	Qty	Part No	English	Deutsch	Francais	Italiano	Espanol	Stock Qty
1400	Ref	U2002710	Lower countershaft assy	Vorgelegewelle untere	Arbre secondaire inferieur	Contalbero inferiore	Eje secundario inferior	1
1500	1	U2002711	Upper countershaft assy	Vorgelegewelle obere	Arbre secondaire superier	Contalbero superiore	Eje secundario superior	1
1410) 1510)	2	14366	Roller bearing	Lager	Roulement	Cuscinetto	Cojnete	4
1420) 1520)	2	14317	Snap ring	Sicherungsring	Circlips	Anello di sicurezza	Anillo elastico	4
1430) 1530)	1	X2010016	Bearing	Lager	Roulement	Cuscinetto	Cojnete	2
1440) 1540)	1	X2014006	Snap ring, bearing, retaining	Sicherungsring	Circlips	Anello di sicurezza	Anillo elastico	2

Reverse Idler Gear, Rückwärtsgang-Umkehrad, Pignon de Renvol de Marche AR, Complesivo Ingranaggio, Rinvio Retromarcia, Engranaje Inversor MA

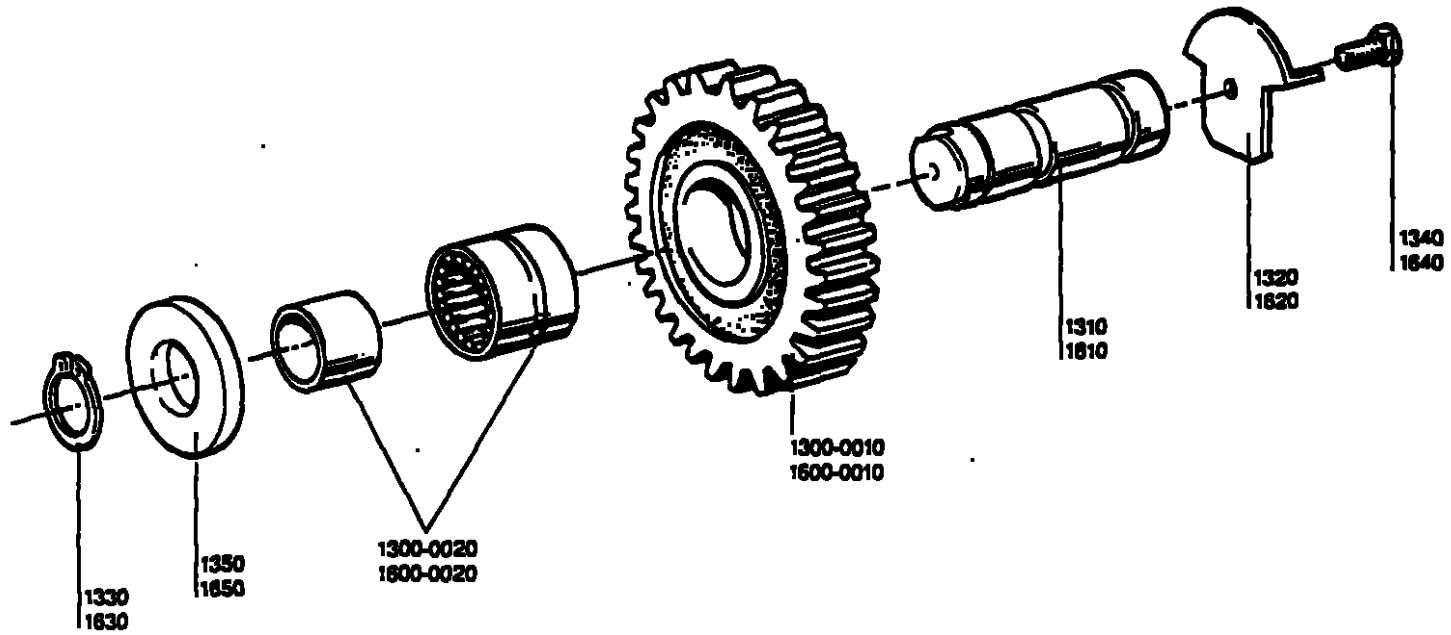

Reverse Idler Gear Assembly, Ruckwartsgang-Umkehrad, pignon de Renvoi-Marche AR, Ingranaggio Rinvio Rm, Conjunto Inversor MA

Section 5

Sequence No	Qty	Part No	English	Deutsch	Francais	Italiano	Espanol	Stock Qty
1300/1600	Ref	U2002121	Reverse idler gear assy	Ruckwartsgang-Umkehrad	Pignon de renvoi MA	Ingranaggio rinvio Rm	Conjunto inversor Ma	
1300-0010} 1600-0010}	2	2005254	Gear	Zahnrad	Pignon	Ingranaggio	Engranaje	4
1300-0020} 1600-0020}	2	X2010002	Needle bearing	Lager	Roulement	Cuscinetto	Cojinete	4
1310} 1610	2	2005052	Shaft	Welle	Axe	Albero	Eje	2
1320} 1620}	2	2005053	Washer	Scheibe	Rondelle	Rondella	Arandela	4
1330} 1640}	2	X2014001	Circlip	Sicherungering	Circlips	Anello di sicurezza	Anillo elastico	4
1340} 1640}	2	X2011523	Screw M10 x 30	Schraube	Vvis	Vite	Tornillo	-
1350} 1650}	2	2005127	Washer	Scheibe	Rondelle	Rondella	Arandela	4

3020

3000

3010

2900

2200-0040

2200-0020

2200-0030

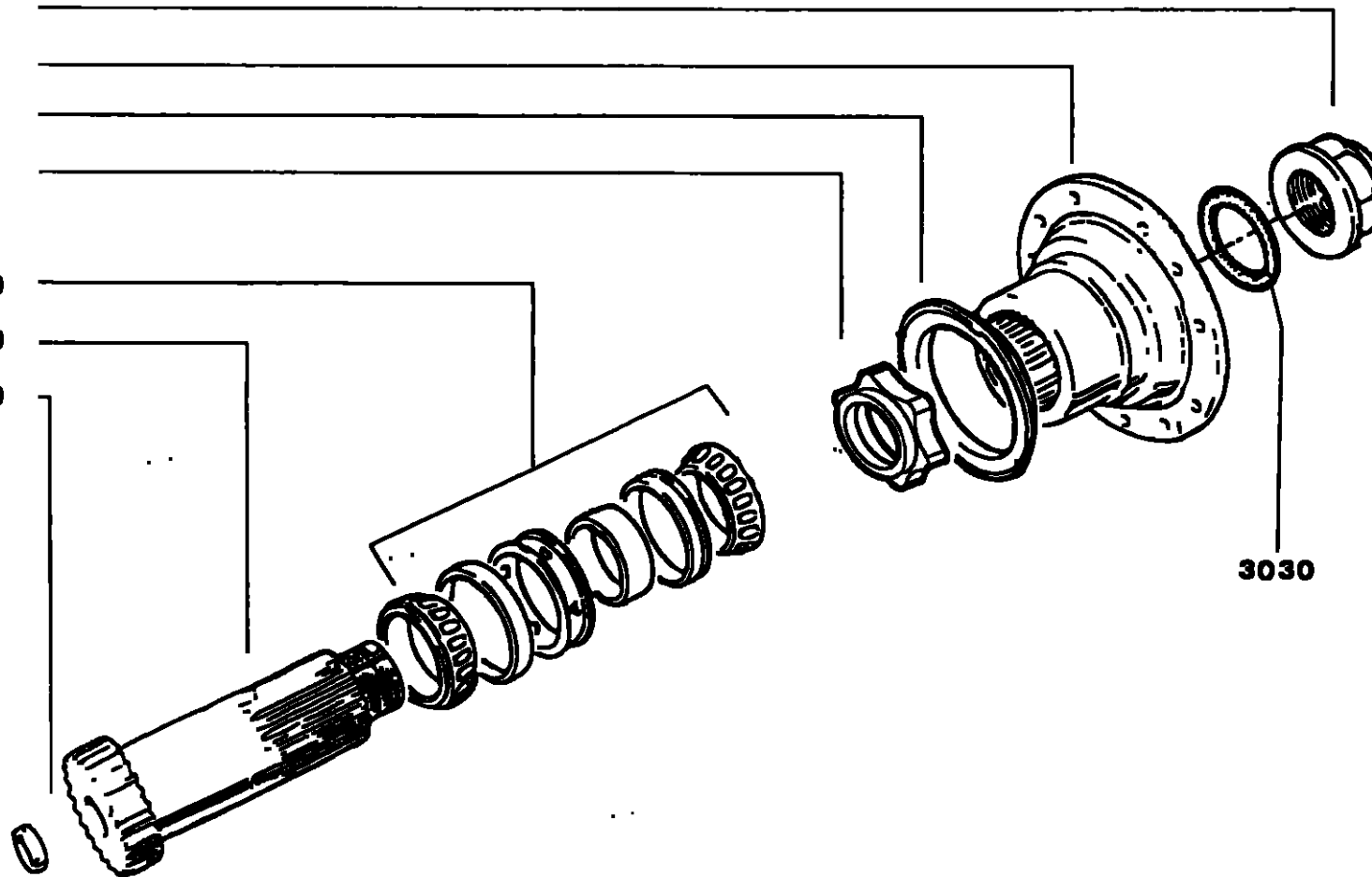

3030

Output Shaft Assembly, Abtriebswelle, Arbre de Sortie, Albero di Uscita, Eje de Salida
Section 6

Sequence No	Qty	Part No	English	Deutsch	Francais	Italiano	Espanol	Stock Qty
2200-0020	1	2005985	Output shaft	Abtriebswelle	Arbre de sortie	Albero di uscita	Eje de salida	1
2200-0030	1	2005207	Bush	Buchse	Bague	Boccole	Casquillo	2
2200-0040	1	15280	Taper roller bearing	Kegelrollenlager	Roulement a rouf.conique	Cuscinetto	Cojinete rodillos conicos	2
2900	0	F99984	Speedo drive gear	Tachoschnecke	Pignon de compteur de vitesse	Ingranaggio comando marca	Engranje conductor del velocimetro	1
	OR							
2900	1	F96130	Rotor	Rotor	Rotor	Rotor	Rotor	-
3000	1	F96255	Cross serration flange	Abtriebswellenflansch	Bnde de sortie	di trasmissione	Plato impulsor de salida	1
	OR							
3000	0	F96437	Yoke-half 1780	Schaltgabel	Fourchette	Forcella	Horquilla	
	OR							
3000	0	20895	Cover-drive shaft	Deckel-abtriebswelle	Couvercle-arbre de sortie	Coperchio-albero di uscita	Tapa-eje de salida	-
3010	1	F96189	Grit shield	Schutzschild	Casse-poussiere	Riparo pietrisco	Recoogeimpurezas	1
3020	1	F96454	Flange nut, staked	Kontermutter	Ecrou	Dado di ritegno	Contratuercas	2
3030	1	F96252	Seal	O Ring	Joint torque	Guarnizione toroidale	Junta torica	3

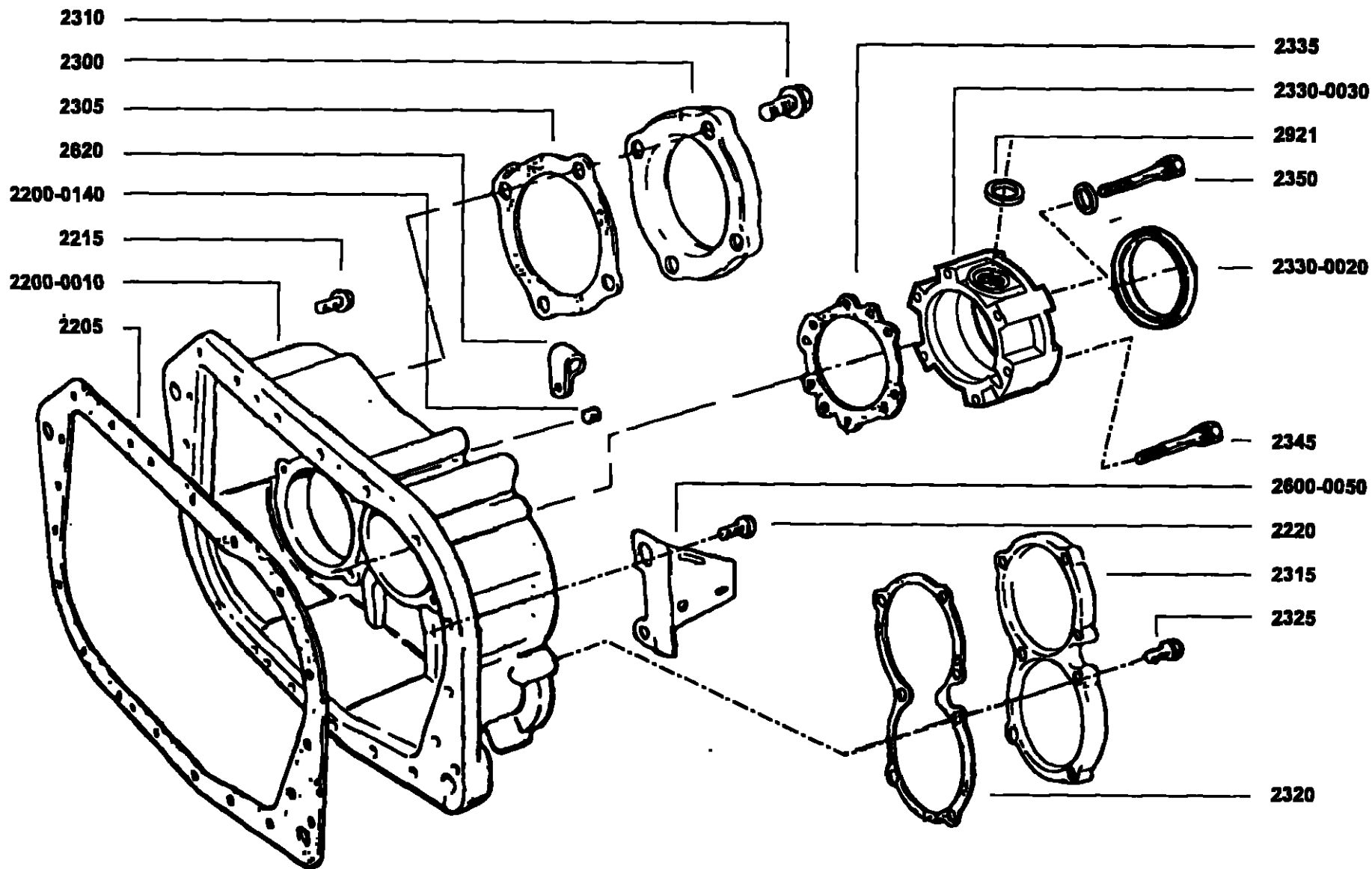

Rear Case Assembly, Nachschaltgruppen-Gehäuse, Carter Arriere Assemble, Complessivo Scatola posteriore, Conjunto Tapa Trasera

Section 6

Sequence No	Qty	Part No	English	Deutsch	Français	Italiano	Espanol	Stock Qty
2200	Ref	U2002717	Rear case assy	-	-	-	-	-
2200-0010	1	2008049	Housing	Gehäuse	Carter	Scatola	Carcasa Auxiliar	1
2200-0140	1	X2013515	Plug	Stopfen	Bouchon	Tappo	Tapon	-
2205	1	2005577	Gasket	Dichtung	Joint	Guarnizione	Junta	-
2215	17	X2011521	Screw/washer assy M10 x 38	Schraube/Federring	Vis/rondelle grower	Vite/rosetta	Tornillo/arandela	-
2220	2	X2011513	Screw/washer assy M10 x 50	Schraube/Federring	Vis/rondelle grower	Vite/rosetta	Tornillo/arandela	-
2230	0	85002	Connector					
	OR							
2230	0	85003	Elbow 90	Winkelverschraubung	Coude	Gornito	Codo	-
2231	0	85002	Connector	-	-	-	-	-
2235	1	21086	Tee 1/8	T-Stuck	Element en T	Pezzo a T	Pieza en T	-
2305	1	17097	Gasket	Dichtung	Joint	Guarnizione	Junta	-
2300	1	2005148	Cover-aux o/shaft brg	Deckel	Couvercle	Coperchio	Tapa	-
2310	4	X11248	Screw M10 x 20	Schraube	vis	Vite	Tornillo	-
2315	1	2005048	Cover	Deckel	Couvercle	Coperchio	Tapa	-
2320	1	2005570	Gasket	Dichtung	Joint	Guarnizione	Junta	-
2325	7	X2011521	Screw/washer assy M10 x 38	Schraube/Federring	Vis/rondelle grower	Vite/rosetta	Tornillo/arandela	-
2330-0010	0	7992	Bush	Buchse	Bague	Boccola	Casquillo	2
2330-0020	1	21036	Oil seal	Dichtring	Joint d'étanchéité	Parasolio	Rede	4
2330-0030	1	2005500	Speedo housing	Deckel, Tachometer	Couvercle, compteur de vitesse	Coperchio, tachimetro	Tapa, velocimetro	1
2335	1	2005146	Gasket	Dichtung	Joint	Guarnizione	Junta	-
2340-0010	0	17106	Gasket - metal	Dichtung	Joint	Guarnizione	Junta	-
2340-0020	0	2005152	Collar - sealing	Scheibe	Collier	Collarino	anillo	-
2340-0030	0	X2011519	Bolt M10 x 75	Schraube	Boulon	Bullone	Perno	-

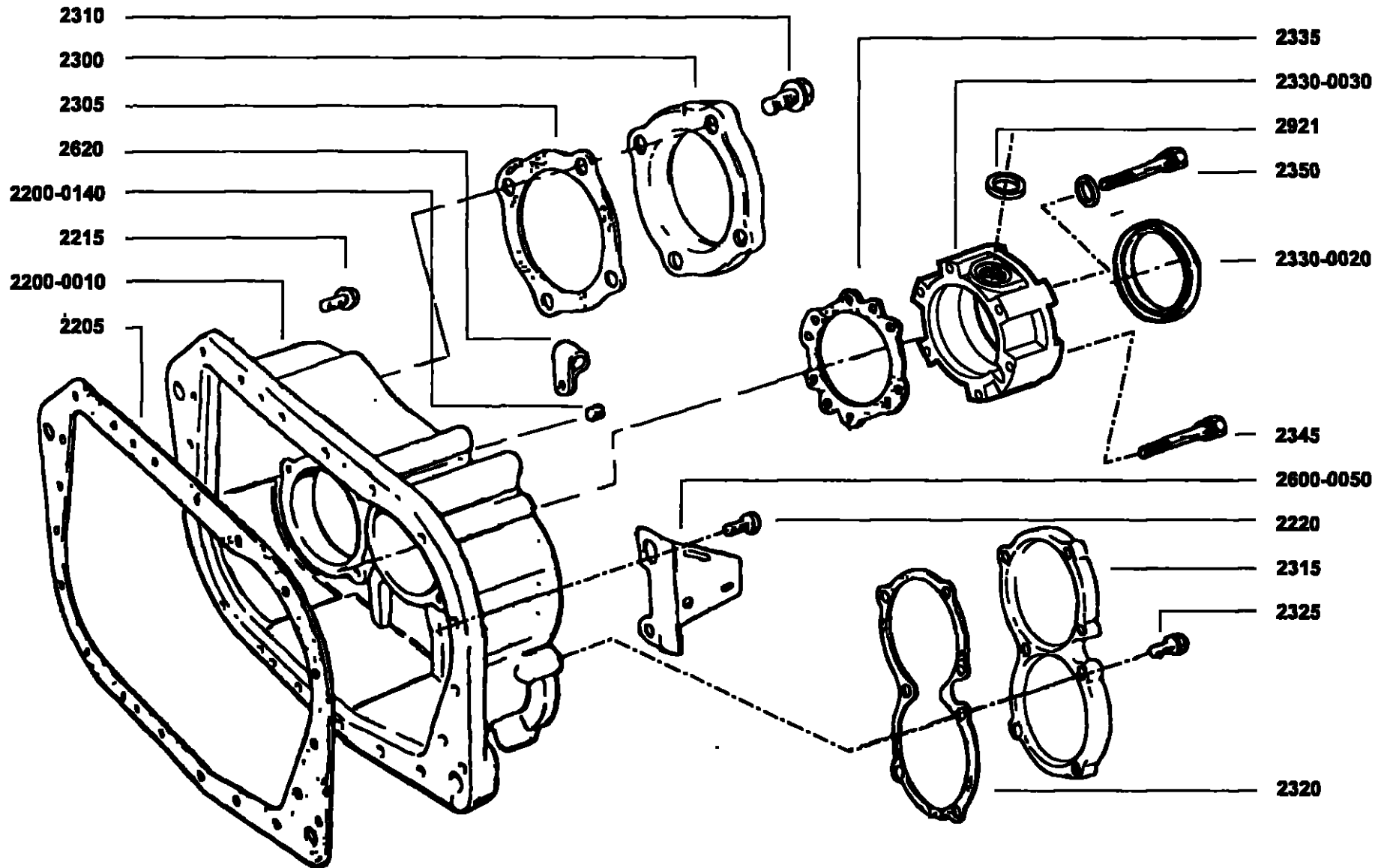

Filter Regulator Assembly, Filter/Regler Einheit, Filtre/Regulateur, Complesivo Filtro/Regulatore, Conjunto Filtro/Regulator

FILTER REGULATOR &
BRACKET ASSEMBLY
2600

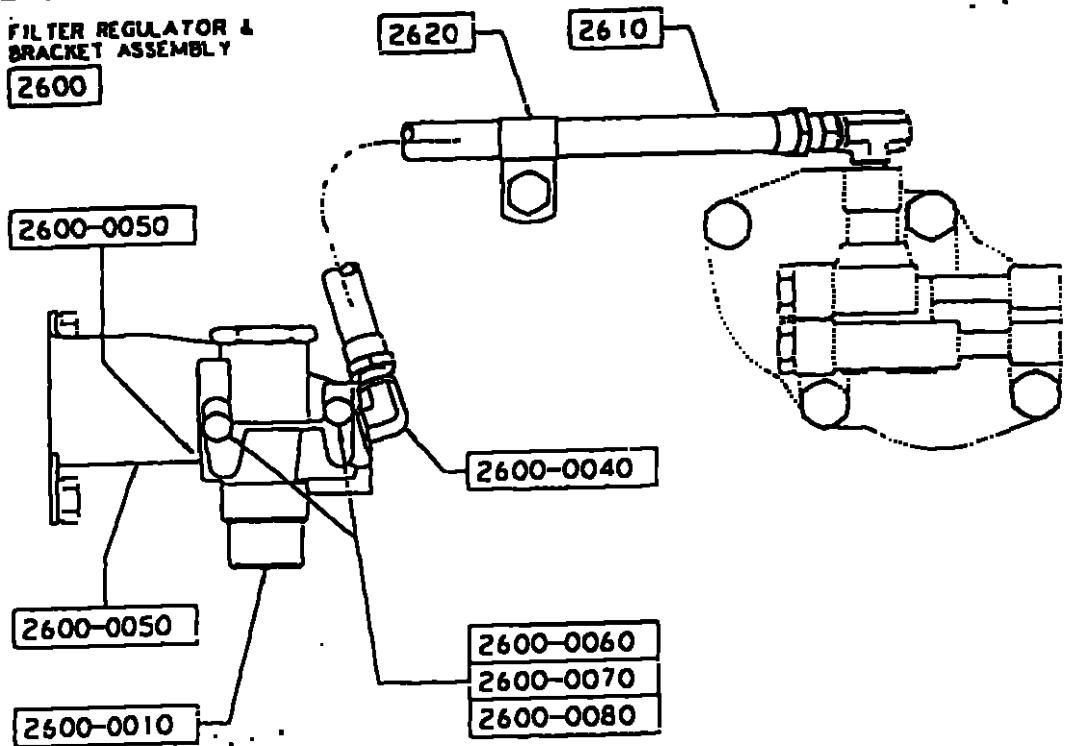

2600 0030

FILTER REGULATOR & BRACKET ASSEMBLY		
SEQUENCE No.	DESCRIPTION	QTY.
2600 - 0010	FILTER REGULATOR	1
2600 - 0020	PIPE PLUG 1/8" NPTF	1
2600 - 0040	ELBOW 90 DEG.	1
2600 - 0050	BRACKET - AIR FILT. REG. ASSY	1
2600 - 0060	M6 SCREW & WASHER ASSY	2
2600 - 0070	WASHER - SPRING M6 TYPE 3	2
2600 - 0080	NUT - HEX M6 . 10	2

REFERENCE PARTS LIST		
SEQUENCE No.	DESCRIPTION	QTY.
2610	FLEXIBLE HOSE ASSY.	1
2620	CLAMP	1
2630	PULSE UNIT ASSY.	1
2640	SCREW M6 . 10 . 35.0	2
2650	BRACKET - AIR FILTER REGULATOR	1
2660	FLEXIBLE HOSE ASSEMBLY	1
2670	ELBOW 90 DEG.	1

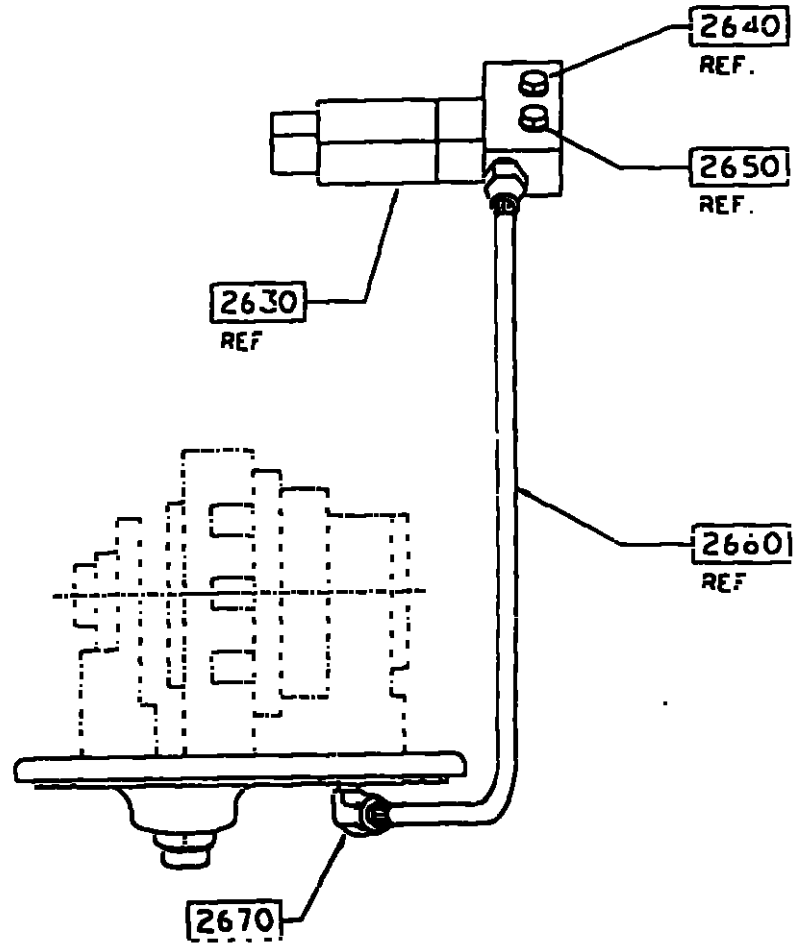

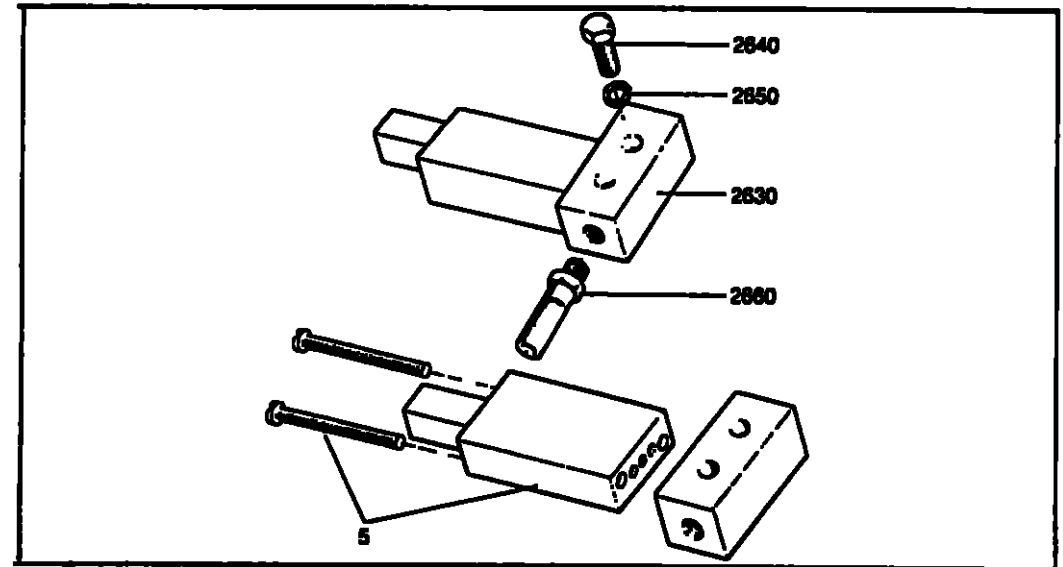
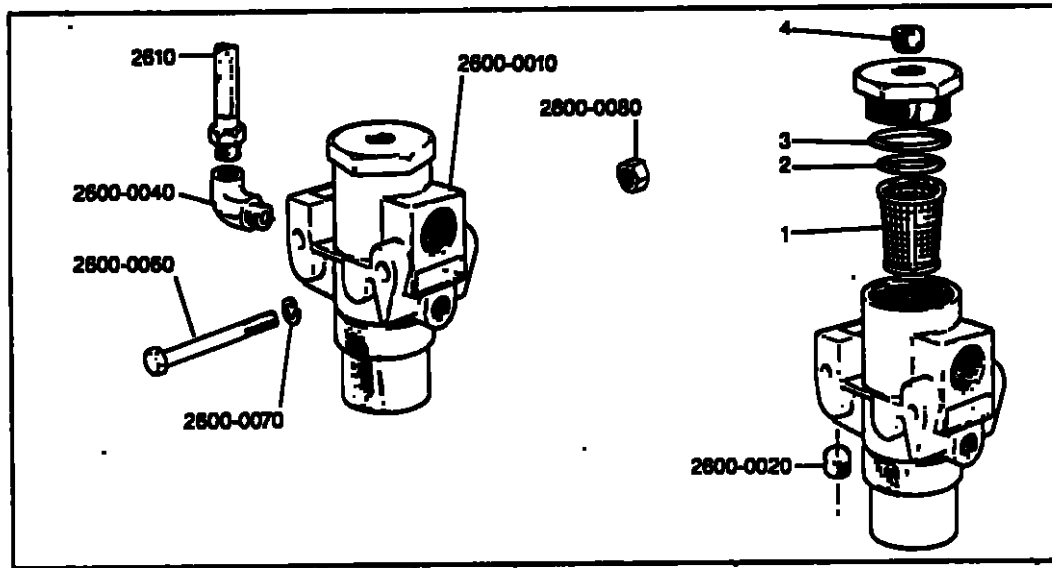

2345	5	X11271	Bolt M10 x 75	Schraube	Boulon	Bullone	Perno	-
2350	1	X2011517	Screw/washer assy M10 x 75	Schraube/Federring	Vis/rondelle grower	vite/rosetta	Tornillo/arendela	
2600-0010	1	2005128	Filter regulator	Filter/regler einheit	Filtre/regulateur	Complessivo filtro/reglatore	Conjunto filtro/regulator	
2600-0020	1	X2013517	Plug	Stopfen	Bouchon	Tappo	Tapon	-
2600-0030	0	2770745	Adaptor	Adapter	Adaptateur	Adattore	Adaptador	-
2600-0040	1	12880	Elbow 45	Winkelverschraubung	Coude	Raccordo a gomita	Tubo acodado	-
2600-0050	1	2005670	Bracket	Halter	Support	Supporto	Soporte	-
2600-0060	2	X2011548	Bolt M6 x 55	Schraube	Boulon	Bullone	Perno	-
2600-0070	2	X2012501	Washer M6	Schiebe	Rondelle	Rosetta	Arandela	-
2600-0080	2	X2012003	Nut M6	Mutter	Ecrou	Dado	Tuerca	-
2610	1	55507	Hose	Schlauch	Flexible	Tubo flessibile	Tuberia	-
2620	1	11665	Clamp	Schelle	Collier	Fascetto	Arazadera	-
2630	1	2005020	Pulse unit assy	-	-	-	-	1
2640	2	X2011508	Bolt M6 x 35	Schraube	Boulon	Bullone	Perno	-
2650	2	X2012501	Washer M6	Schiebe	Rondelle	Rosetta	Arandela	-
2660	1	X2014106	Hose	Schlauch	Flexible	Tubo flessibile	Tuberia	-
2670	1	12845	Elbow	Winkelverschraubung	Coude	Raccordo a gomita	Tubo acodado	-
2910	0	F91004	Speedo pinion 14T	Tachometarriztel	Pignon de tachymetre	Pignone indicatore di velocita	Pinon de velocidad	1
2920	0	F96005	Washer	Scheibe	Rondelle	Rosetta	Arandela	-
2921	1	F96063	Copper washer	Scheibe, kupfer	Rondelle en cuivre	Rondelle in rame	Arandela de cobre	-
2930	0	F93060	Speedo adaptor assy	Tachometeranschluss	Adapteur de tachymetre	Addatore Indicatore di velocita	Adaptor del velocidad	1

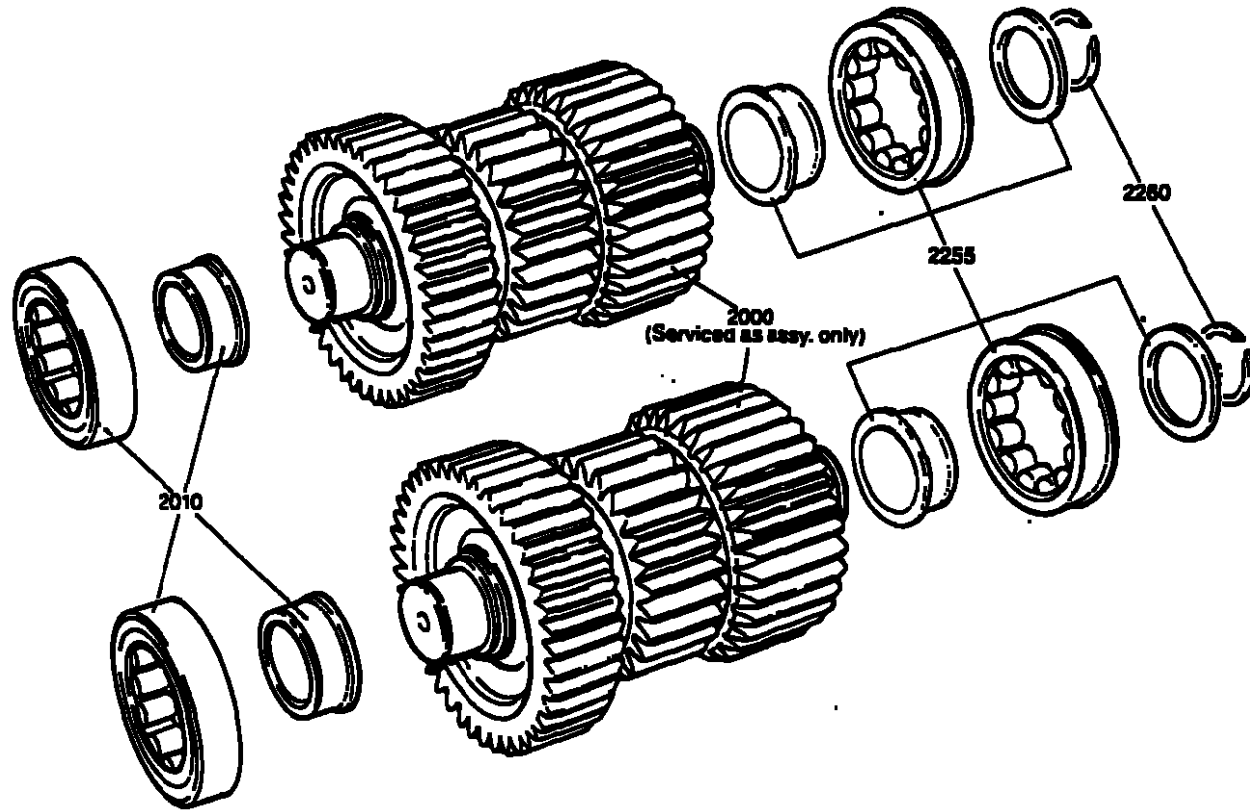

Auxiliary Countershaft Assy, Vorgelegewelle Nachschaltgruppe, Arbre Secondaire Auxiliaire, Contralbero Ausil Completo, Conjunto Eje Secundario Auxliar
Section 7

Sequence No	Qty	Part No	English	Deutsch	Francals	Itallano	Espaniol	Stock Qty
2000	Ref	U2002414	Countershaft assy-direct	Vorgelegewelle	Arbre secondaire auxliars	Contralbero ausil completo	Conjunto eje secundario	1
2010	2	X2010027	Roller bearing	Lager	Roulement	Cuscinetto	Cojinete	4
2020	-	X11426	Loctite 601	Loctite 601	Loctite 601	Loctite 601	Loctite 601	-
2255	2	X11313	Bearing	Lager	Roulement	Cuscinetto	Cojinete	4
2260	2	X2014010	'K'ring	'K'sicherungsring	'K'circlips	'K'anello di sicurezza	'K'anillo elastico	4

Upshift Brake Assembly, Getriebebremse, Frein d'Inertie, Freno d'Inerzia, Freno de Cambios Hacia Arriba

For Serial Nos N 533587 and above.
 Ab Serienr. N 533587.
 Cette section concerne les références
 suivantes: N 533587 et au dessus.
 Per i numeri di matricola fino a partire da
 N 533587.
 Para los números de serie: N 533587 y
 siguientes.

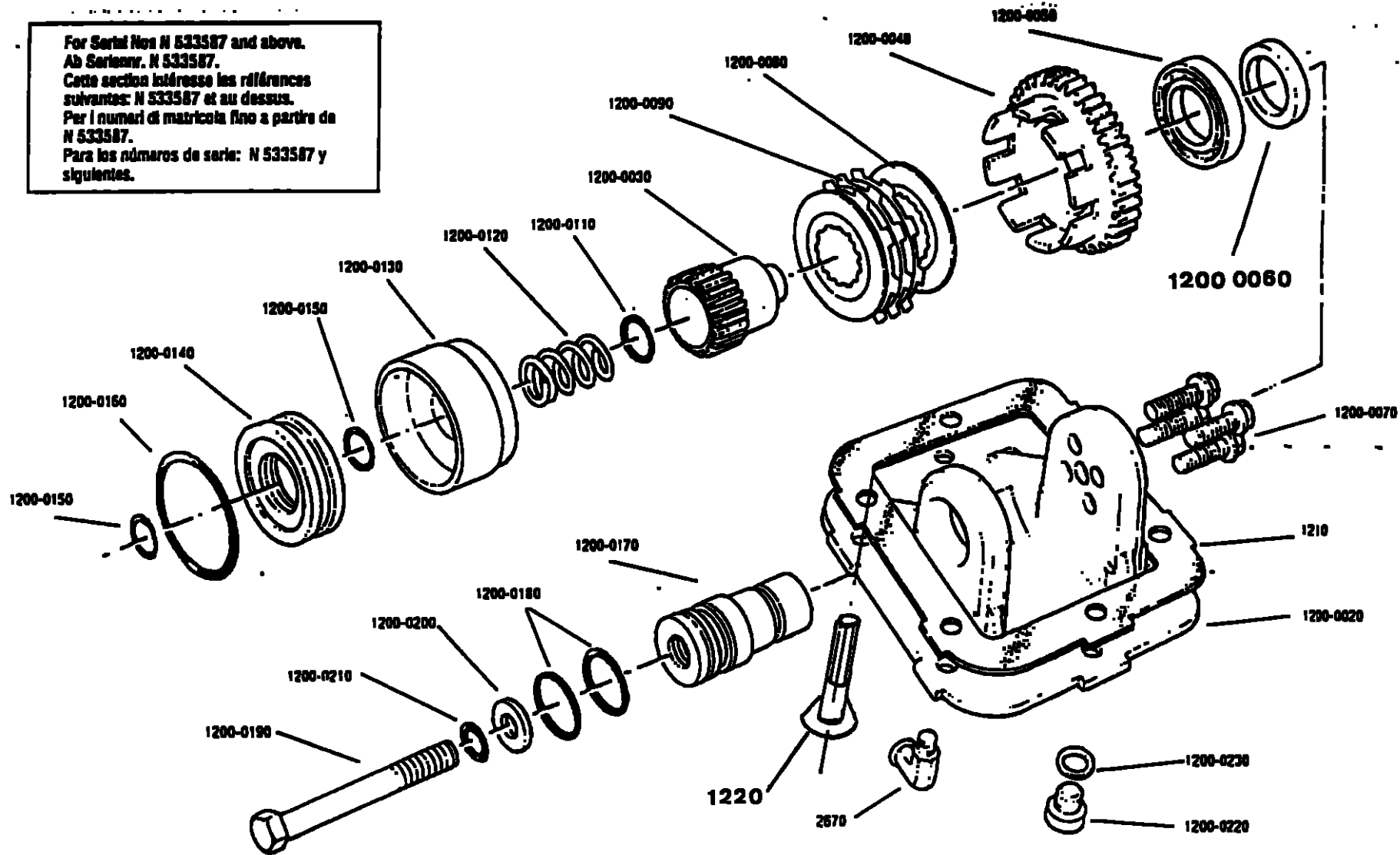

Upshift Brake Assembly, Getriebbremse, Frein d'Inertie, Freno d'Inerzia, Freno de Cambios Hacia Arriba

Section 9

Sequence No	Qty	Part No	English	Deutsch	Francais	Italiano	Espanol	Stock Qty
1200	Ref	U2002337	Upshift brake assy	Getriebbremse	Frein d'inertie	Freno d'inerzia	Freno de cambios hacia arriba	
1200-0020	1	2005726	Housing	Deckel	Carter	Supporto	Envueta	
1200-0030	1	2005702	Splined shaft	Keilwelle	Axe cannelé	Alberino scanalato	Eje estriado	
1200-0040	1	2005834	Gear	Zahnrad	Pignon	Ingranaggio	Engranaje	
1200-0050	1	X2010023	Bearing	Lager	Roulement	Cuscinetto	Cojinete	
1200-0060	1	X2014160	Spacer	Distanzring	Entretoise	Distanziale	Separador	
1200-0070	4	X2011588	Bolt M8 x 30	Schraube	Boulons	Vite	Pasadores	
1200-0080	4	2005076	Friction disc - Inner	Innere Bremsscheibe	Disque de frein Interne	Disco di attrito interno	Disco de friccion - Interior	
1200-0090	3	2005077	Friction disc - outer	Aussere Bremsscheibe	Disque de frein externe	Disco di attrito esterno	Disco de friccion - exterior	
1200-0110	1	X2011035	O ring	O ring	Joint torique	Guarnizione O ring	Junta torica	
1200-0120	1	2005625	Spring	Druckfeder	Ressort	Molla	Muelle	
1200-0130	1	2005624	Pressure plate	Druckplatte	Plaque de pression	Springidisco	Placa de presion	
1200-0140	1	2005623	Piston	Kolben	Piston	Pistone	Piston	
1200-0150	2	X2011036	O ring	O ring	Joint torique	Guarnizione toroidale	Junta tori	
1200-0160	1	X2011037	O ring	O ring	Joint torique	Guarnizione toroidale	Junta torica	
1200-0170	1	2006329	Shaft	Welle	Axe	Albero	Eje	
1200-0180	2	X2011003	O ring	O ring	Joint torique	Guarnizione Toroidale	Junta torica	
1200-0190	1	MX-8-1015	Bolt M10	Schraube	Boulon	Vite	Esparrago	
1200-0200	1	X11245	Washer	Scheibe	Rondelle	Rondella	Arandela	
1200-0210	1	X2011034	O ring	O ring	Joint torique	Guarnizione toroidale	Junta torica	
1200-0220	1	X2013521	Drain plug	Ablassschraube	Bouchon de drainage	Tappo di scarico	Tapon de vaciado	
1200-0230	1	F96005	Washer	Scheibe	Rondelle	Rondella	Arandela	
1210	1	2005572	Gasket	Dichtung	Joint d'etanchéité	Guarnizione piana	Junta	
1220	6	X2011615	Cap screw M10 x 25	Schraube	Vis	Vite	Tornillo	
2670	1	12845	Elbow	Winkelverschraubung	Coude	Raccordo a gomita	Tubo acodado	

er Cylinder Assembly, Splitter Zylinder, Cylindre du Relais, Servo Cilindro, Cilindro Splitter

TS(O) 11612A TS(O)

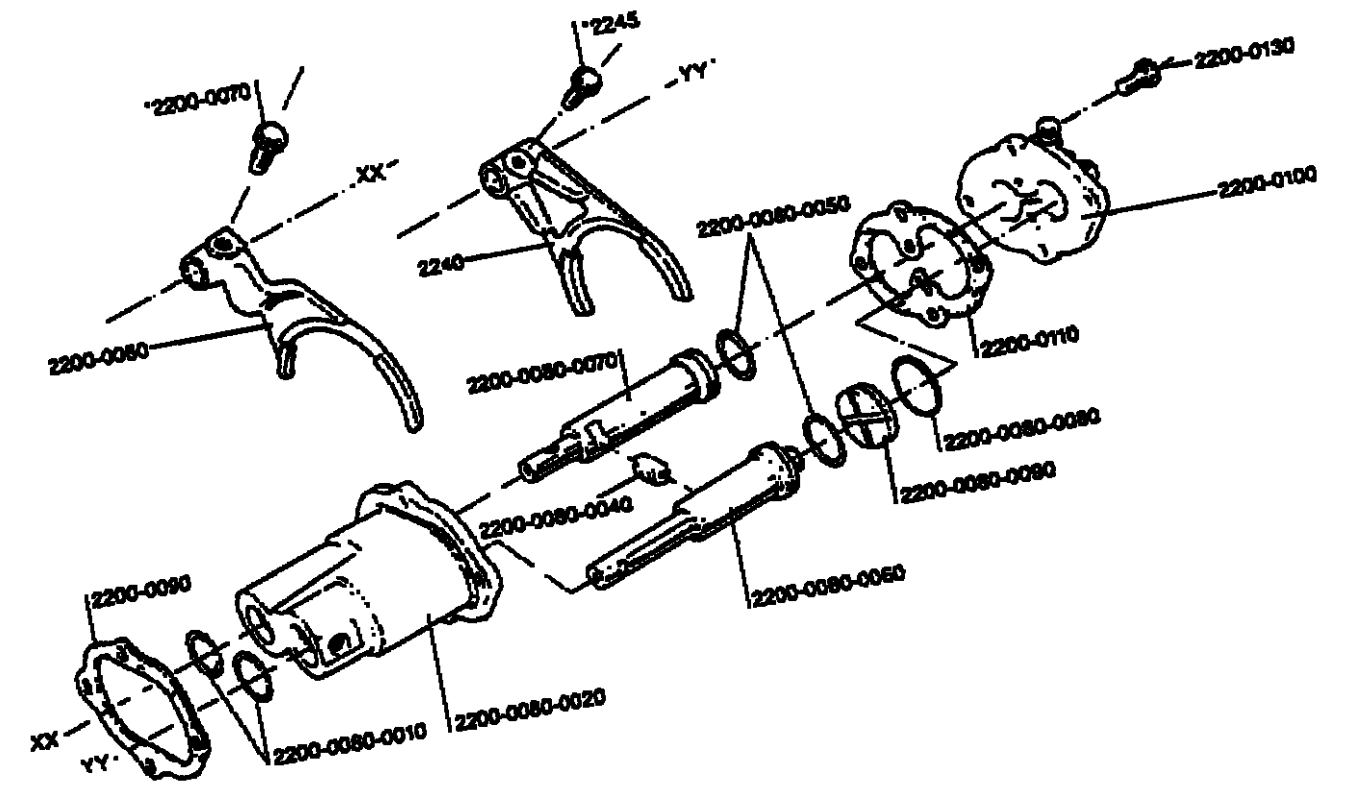

- Use Lockwire.
- Mit Draht sichern.
- Utiliser fil de sécurité.
- Usare filo bloccaggio.
- Usar alambre de seguridad.

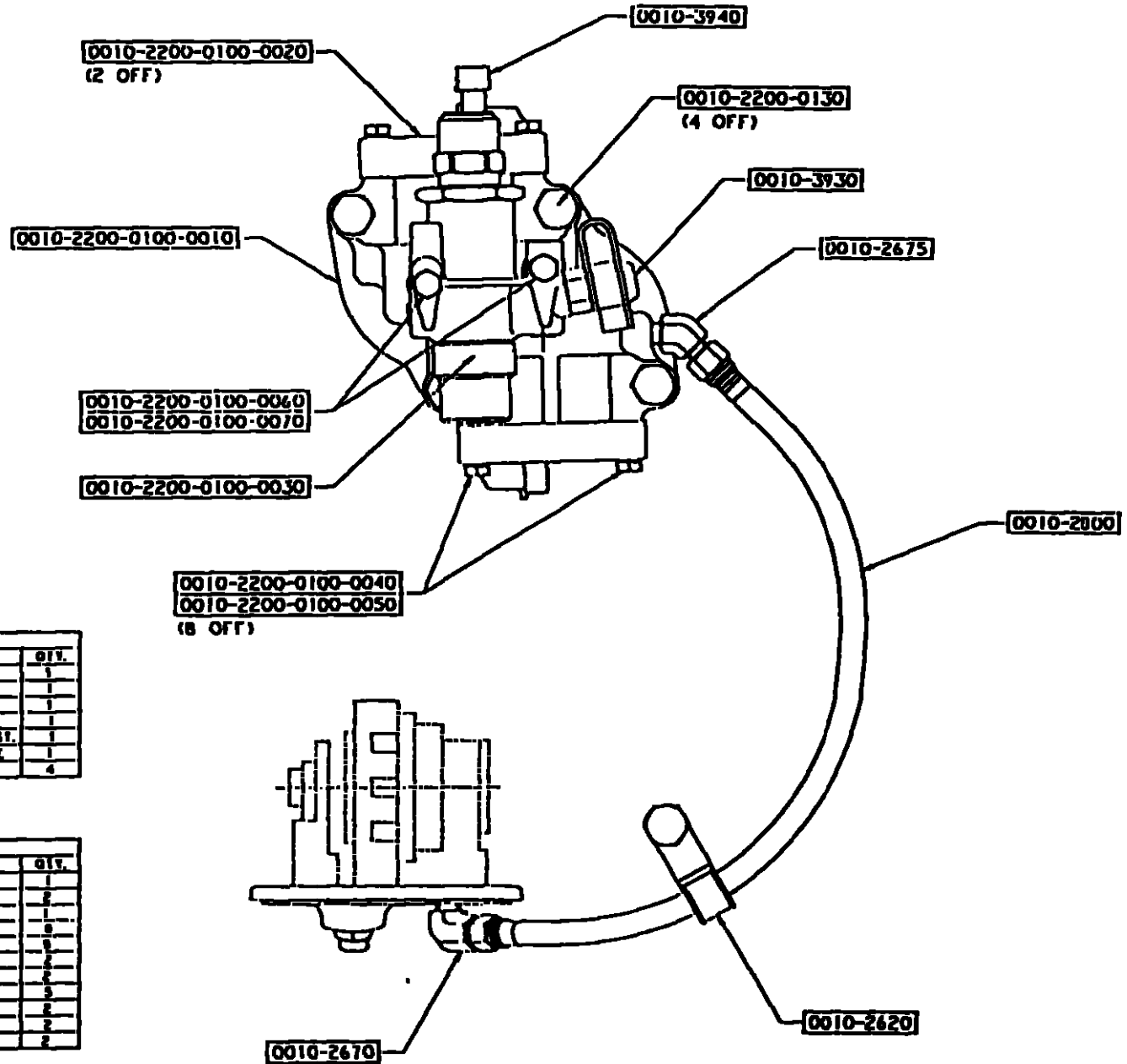

AIR SYSTEM COMPONENTS		
SEQUENCE No.	DESCRIPTION	QTY.
0010-2670	CLAMP	1
0010-2670	ELBOW 90 DEG	1
0010-2675	45 DEGREE ELBOW	1
0010-2800	HOSE ASSEMBLY	1
0010-3930	CONNECTION PRESSURE TEST.	1
0010-3940	SWITCH-LOW AIR PRESSURE	1
0010-2200-0130	BOLT M10 x 1.5	4

SPLITTER COVER - ASSEMBLY		
SEQUENCE No.	DESCRIPTION	QTY.
0010-2200-0100-0010	COVER-SPLITTER VALVES	1
0010-2200-0100-0020	SOLENOID VALVES	2
0010-2200-0100-0030	PII TRAP & ASSY.	1
0010-2200-0100-0040	WASHER M4 x 15	2
0010-2200-0100-0050	WASHER M4	2
0010-2200-0100-0060	BOLT M4 x 10 x 55	2
0010-2200-0100-0070	WASHER M4	2
0010-2200-0100-0080	PIPE PLUG 1/8 PTIF	2
0010-2200-0100-0090	AVIAL PLUG M4	2
0010-2200-0100-0100	AVIAL PLUG M4	2
0010-2200-0100-0110	O RING	2

Splitter Cylinder Assembly, Splitter Zylinder, Cylindre du Relais, Servocilindro, Cilindro Splitter
Section 10

Sequence No	Qty	Part No	English	Deutsch	Francais	Italiano	Espanol	Stock Qty
2200-0060	1	2005541	Yoke	Schaltgabel	Fourchette	Forcella	Horquilla	2
2200-0070	1	15776	Screw	Schraube	Vis	Vite	tornillo	-
2200-0080	Ref	U2002540	Aux shift cylinder assy	Zylinder	Cylindre	Cilindro	Cilindro	
2200-0080-0010	2	X2014174	Seal-GLYD RING	Dichtring	Joint etancheite	Guarnizione tenuta	Reten	2
2200-0080-0020	1	2005979	Shift cylinder	Splitter zylinder	Cylindre du relais	Servo cilindro	Cilindro Splitter	1
2200-0080-0040	1	2005171	Pin	Sperrzapfen	Doigt de verrouillage	Nottolino di consenso	Pasador inetrbloqueo	2
2200-0080-0050	2	X2011006	O ring	O ring	joint torique	Guarnizione toroidale	Junta torica	6
2200-0080-0060	1	2005010	Piston	Kolben	Piston	Stantuffo	Piston	1
2200-0080-0070	1	2005173	Piston	Kolben	Piston	Stantuffo	Piston	1
2200-0080-0090	1	U2002615	Piston assy	Kolben	Piston	Stantuffo	Piston	1
2200-0080-0100	-	2006122	Silicon lubricant	Silikonschmierung	Lubrifiant au silicone	Lubrificante di silicone	Silicone lubricante	1
2200-0090	1	2005573	Gasket	Dichtung	Joint	Guarnizione	Junta	2
2200-0100	1	2006310	Shift cover assy	Deckelgehäuse	Couvercle	Coperchio	Conjunto tapa	-
2200-0110	1	2005746	Gasket	Dichtung	Joint	Guarnizione	Junta	2
2200-0120	0	X2012504	Lockwasher	Federring	Rondelle grower	Rosetta elastica	Arandela elastica	-
2200-0130	4	MX-8-1016	Screw M10 x 40	Schraube	Vis	Vite	tornillo	-
2240	1	2005542	Yoke	Schaltgabel	Fourchette	Forcella	Horquilla	2
2245	1	15776	Screw	Schraube	vis	vite	Tornillo	-

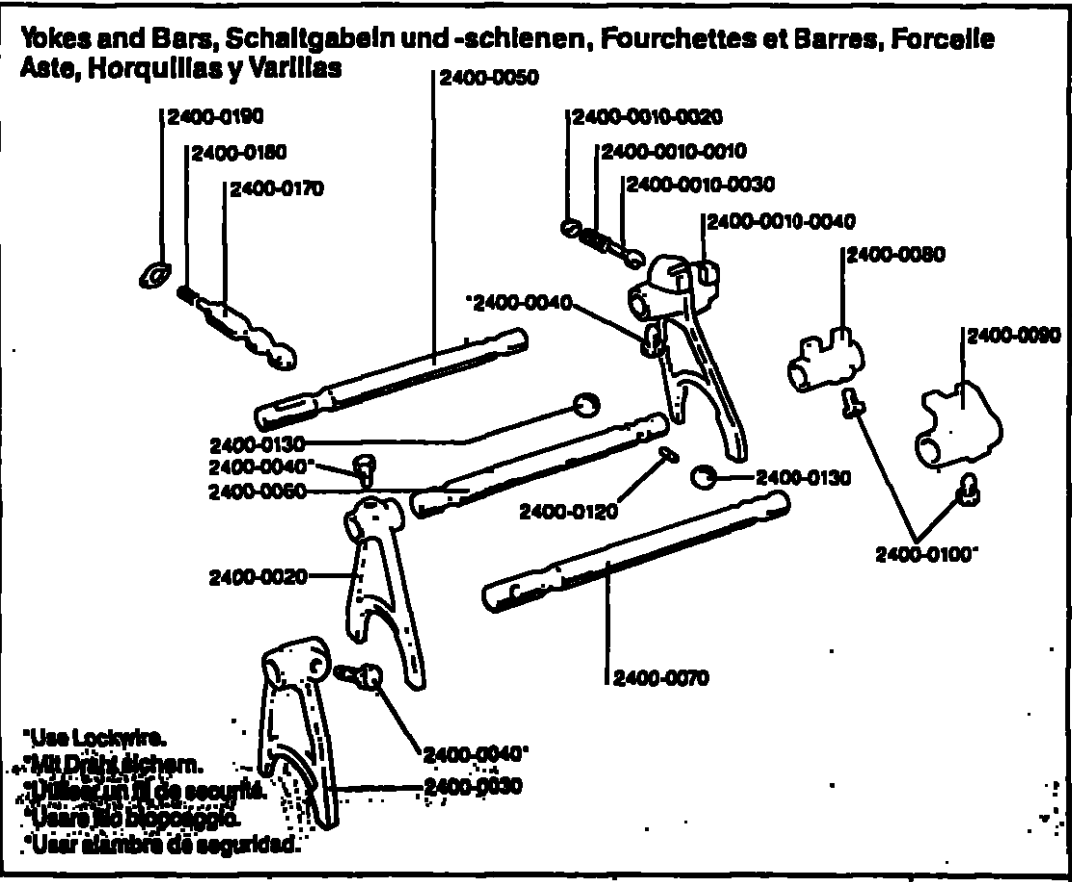
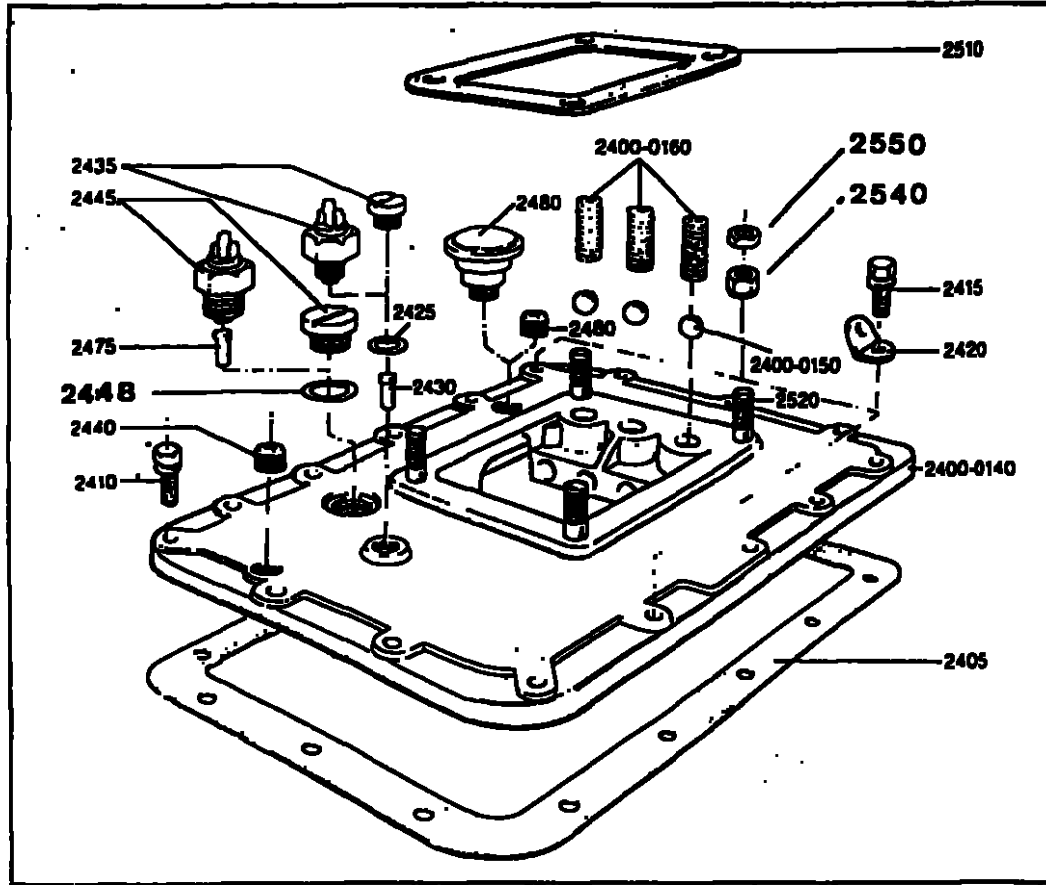

Sequence No	Qty	Part No	English	Deutsch	Français	Italiano	Español	Stock Qty
2400-0160	3	2005019	Spring	Feder	Ressort	Molla	Muelle	3
2400-0170	1	2005725	Shaft neutral switch actuator	Betätigungskolben schalter für neutralstellung	Plongeur-contracteur de point mort	Otturatore di comando Interruttore di folle	Vastago-activador interruptor neutro	-
2400-0180	1	2005017	Spring	Feder	Ressort	Molla	Muelle	-
2400-0190	1	2005187	Plate	Platte	Plaque	Piastra	Placa	-
2405	1	2005578	Gasket	Dichtung	Joint	Guarnizione	Junta	-
2410	14	MX-8L-1017	Screw washer M10 x 35	Schraube/Federring	Vis/rondelle	Vite/rosetta	Tornillo/arandela	-
2415	2	MX-8L-1019	Screw washer	Schraube/Federring	Vis rondelle grower	Vite/rosetta	Tornillo/arandela	-
2420	2	20815	Lifting eye	Hebeose	Patte de levage	Anello di sollevamento	Placa de izar	-
2425	1	5568510	'O'ring	'O'ring	Joint torique	Guarnizione toroidale	Junta torica	1
2430	1	2006041	Actuating pin	Stift	Goupille	Alberino	Pasador	-
2435	1	2771532	Reverse/bay switch	Rückfahrshalter	Conducteur de marche AR	Interruttore retromarcia	Interr marcha atras	1
2440	1	X2013516	Pipe plug	Verschlusschraube	Bouchon filete	Tappo filettato	Tapon	-
2445	1	2771842	Neutral switch	Neutralstellungshalter	Contacteur de point mort	Interruttore folle	Interruptor de punto muerto	1
	OR							
2445	0	X2013513	Plug	Stopfen	Bouchon	Tappo	Tapon	
2448	0	X14178	Washer	Scheibe	Rondelle	Rosetta	Arandela	-
2448	1	5568510	'O'ring	'O'ring	Joint torique	Guarnizione toroidale	Junta torica	1
2450	0	17179	Gasket	Dichtung	Joint	Guarnizione	Junta	1
2475	0		Actuating pin	Stift	Goupille	Alberino	Pasador	-
2480	1	X2013515	Pipe plug	Verschlusschraube	Bouchon filete	Tappo filettato	Tapon	-
	OR							
2480	0	23605	Breather	Entlüfter	Reniflard	Sfiatatoi	Respiro	-
2510	1	1642	Gasket, shift lever	Dichtung	Joint	Guarnizione	Junta	1

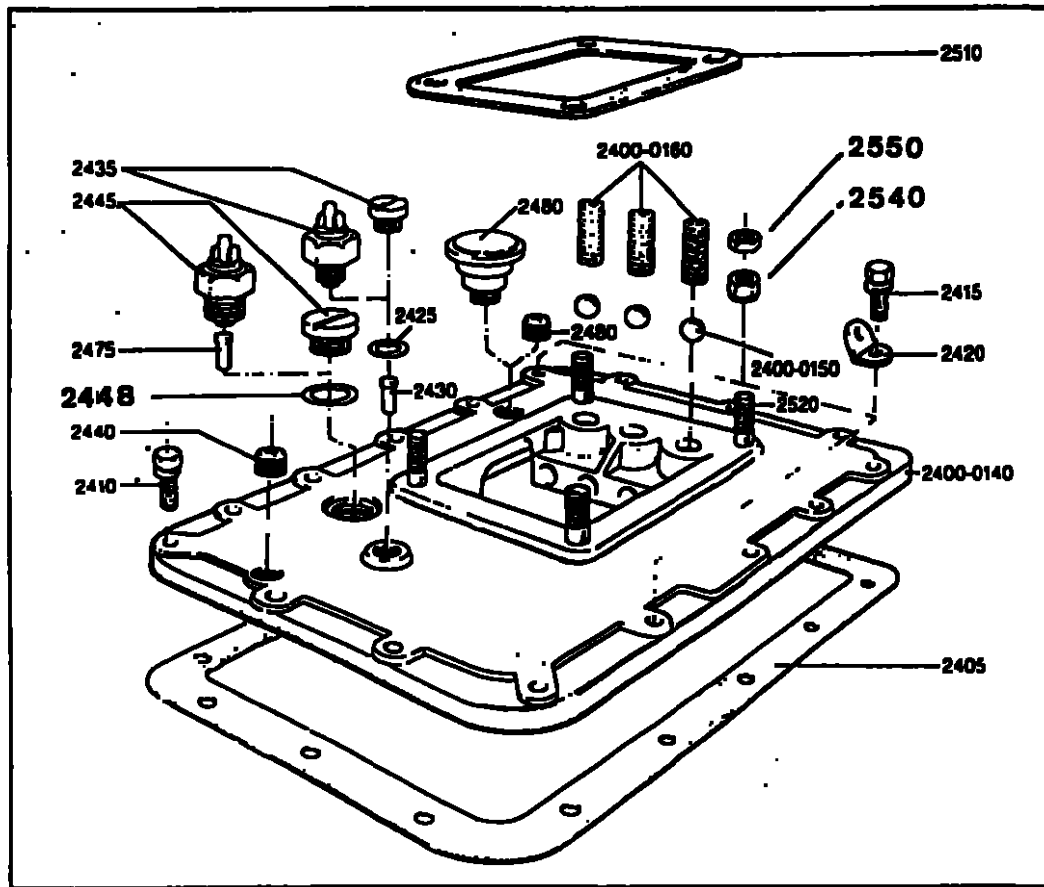

Yokes and Bars, Schaltgabeln und -schlenen, Fourchettes et Barres, Forcette Aste, Horquillas y Varillas

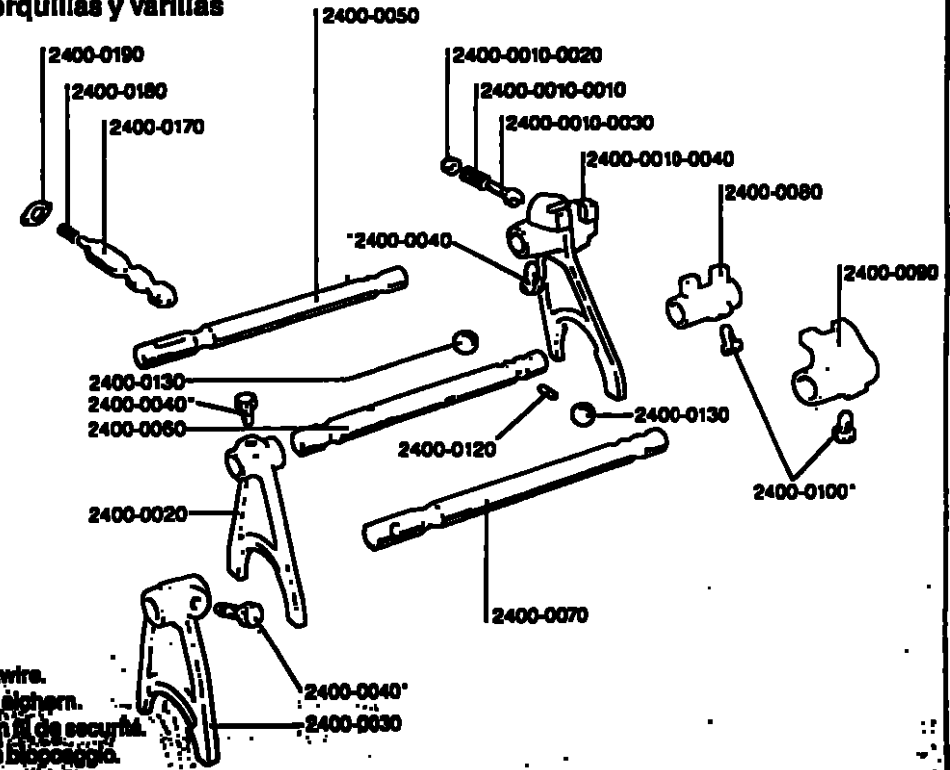

*Use Lockwire.
*Verdraht sichern.
*Utiliser un fil de sécurité.
*Usare filo di sicurezza.
*Usar alambre de seguridad.

Shift Bar Housing Assembly, Schaltdeckel, Couvercle de Changement de Vitesse, Coperchio Selettore, Tapa de Varillas

Section 12

Sequence No	Qty	Part No	English	Deutsch	Français	Italiano	Espanol	Stock Qty
2400	Ref	U2002902	Shift bar housing assy	Schaltdeckel	Couvercle	Coperchio selettore	Tapade varillas	
2400-0010-0010	1	6392	Spring	Feder	Ressort	Molla	Muelle	-
2400-0010-0020	1	8968	Plug	Stopfen	Bouchon	Tappo	Tapon	-
2400-0010-0030	1	10019	Shift detent plunger	Kolben	Verrouillage	Perno di reazione	Vestago	-
2400-0010-0040	1	2005231	Yoke, reverse	Schaltgabel-Ruckwarts	Fourchette Marche AR	Forcella cambio-retomarcia	Horquilla MA	1
2400-0020	1	2005012	Yoke 1st & 2nd	Schaltgabel 1/2 Gang	Fourchette 1ere/2nde	Forcella 1a/2a	Horquilla 1a/2a	1
2400-0030	1	2005229	Yoke 3rd & 4th	Schaltgabel 3/4 Gang	Fourchette 3eme/dir	Forcella 3a/diretta	Horquilla 3a/4a	1
2400-0040	3	15776	Lock Screw	Arretierschraube	Vis de blocage	Vite	Tornillo	
2400-0041	3	1819	Lockwire	Draht	Fil de securite	Filo bloccaggio	Alambre de seguridad	-
2400-0050	1	2006359	Bar, reverse	Schaltschiene R-Gang	Axe de fourchette marche AR	Selettore cambio-retromarcia	Varilla MA	-
2400-0060	1	2005124	Bar 1st & 2nd	Schaltschiene 1/2 Gang	Axe de fourchette 1ere/2nde	Asta di comando 1a/2a	Varilla 1a/2a	-
2400-0070	1	2006347	Bar 3rd & 4th	Schaltschiene 3/4 Gang	Axe de fourchette 3eme/dir	Asta di comando 3a/dir	Varilla 3a/4a	-
2400-0080	1	2005232	Block 1st & 2nd	Schaltblock 1/2 Gang	Selecteur 1ere/2nde	Nasello cambio 1a/2a	Selector 1a/2a	-
2400-0090	1	2005118	Block 3rd & 4th	Schaltblock 3/4 Gang	Selecteur 3eme/dir	Nasello cambio 3a/dir	Selector 3a/4a	-
2400-0100	2	15776	Lockscrew	Arretierschraube	Vis de blocage	Vite	Tornillo	-
2400-0110	-	1819	Lockwire	Draht	Fil de securite	Filo bloccaggio	Alambre de seguridad	-
2400-0120	1	1834	Pin	Stift	Goupille	Alberino	Pesador	-
2400-0130	2	X-14-1200	Ball 3/4"	Kugel	Bille	Sfera	Bola	3
2400-0140	1	2006357	Shift bar housing	Schaltdeckel	Couvercle de changement de vitesse	Coperchio selettore	Tapa de varillas	1
2400-0150	3	X-14-800	Ball 1/2"	Kugel	Bille	Sfera	Bola	3

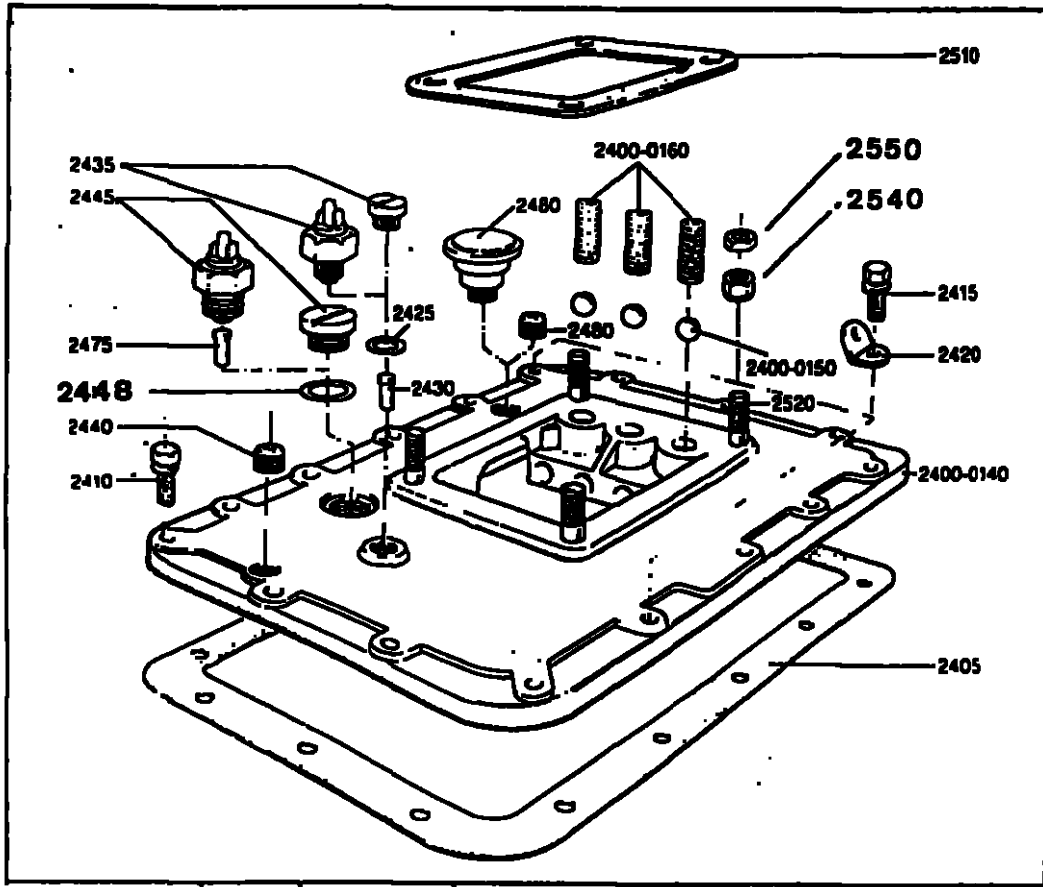

Yokes and Bars, Schaltgabeln und -schienen, Fourchettes et Barres, Forcelle Aste, Horquillas y Varillas

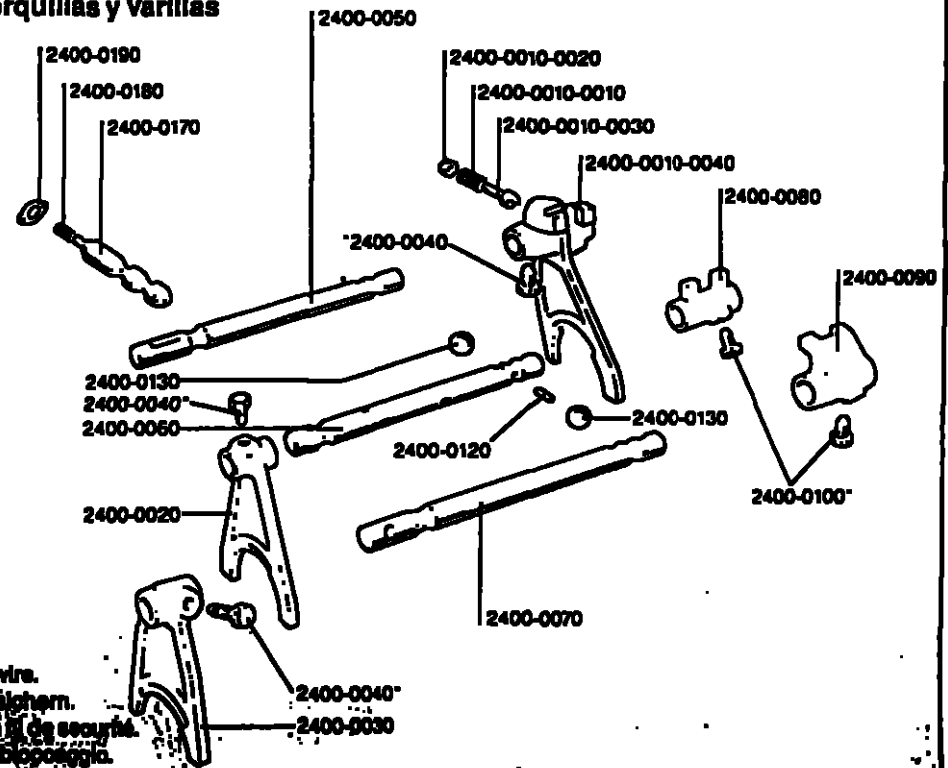

*Use Lockwire.
 *Mit Draht sichern.
 *Utiliser un fil de sécurité.
 *Usare filo di sicurezza.
 *Usar alambre de seguridad.

Sequence No	Qty	Part No	English	Deutsch	Francals	Itallano	Espaniol	Stock Qty
2520	4	X2014194	Stud M10 x 55	Stiftschraube	Goujon	Pigioniero	Esparrago	-
2540	4	X11282	M10 conical nut	Mutter M10	Ecrou M10	Dado M10	Tuerca M10	-
2550	4	X11283	M10 lock nut	Sicherungsmutter m10	Ecro M10	Dado M10	Tuerca M10	

LRC Remote Control Assembly, Fernschaltung, Commande a Distance, Complessivo Comando a Distanza, Conjunto Control Remoto

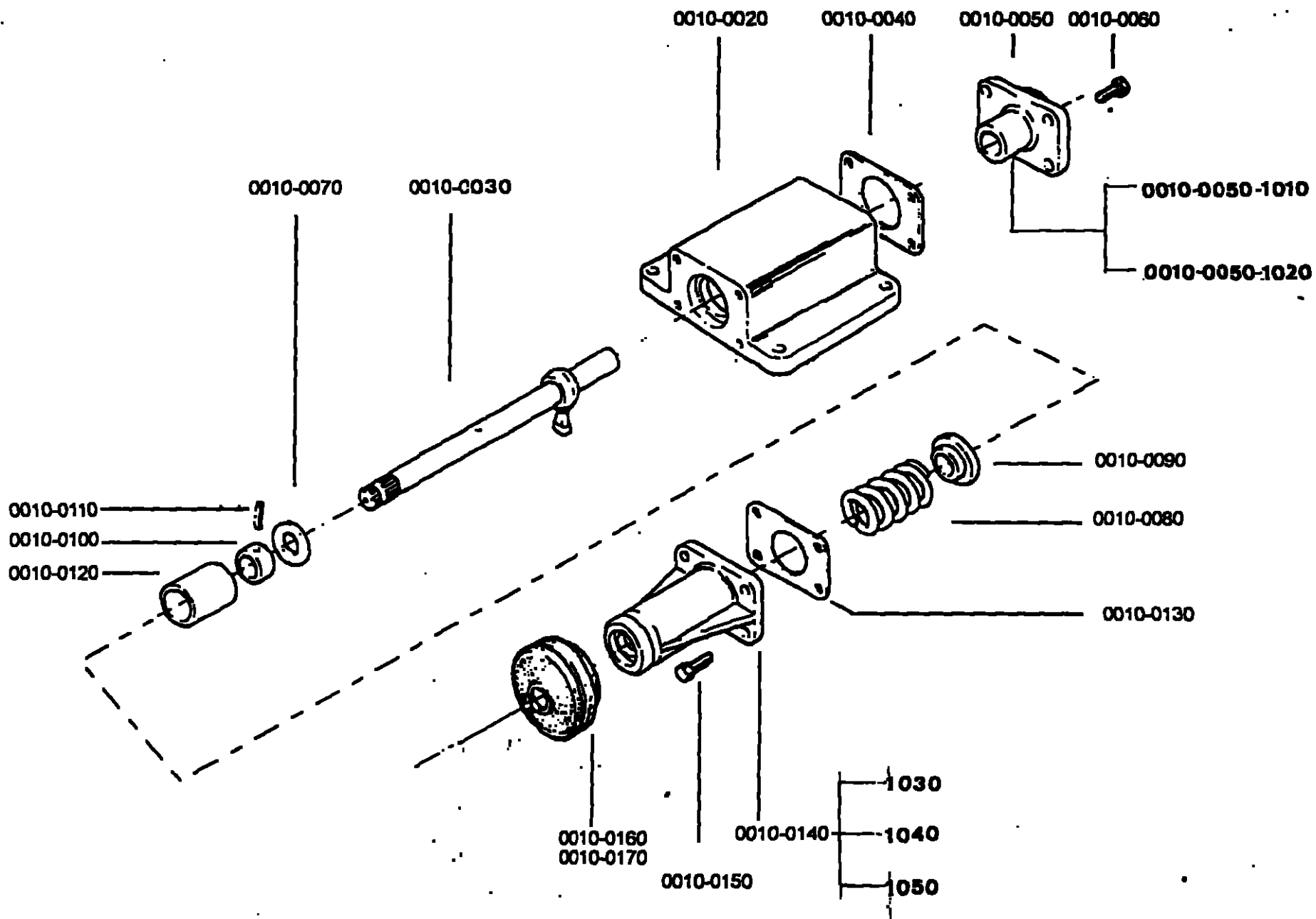

Control, Fernschaltung, Commande a Distance, Complessivo Comando a Distanza, Conjunto Control Remoto

Section 13

Sequence No	Qty	Part No	English	Deutsch	Francais	Italiano	Espanol	Stock Qty
2500	Ref	U2002092	LRC Assy - LHD	-	-	-	-	-
2500-0010	1	U2002250	LRC single bias-LH	-	-	-	-	-
2500-0010-0020	1	2005168	Housing Centre LRC	Gehäuse	Corps	Scatola	Envuelta	-
2500-0010-0030	1	F93207	Cross shaft assy LRC	Schaltwelle	Axe transversal	Albero trasversale	Eje transversal	-
2500-0010-0040	1	F98457	Joint	Dichtung	Joint	Guarnizione	Junta	1
2500-0010-0050-1010	1	G36327	End cap	Deckel	Couvercle	Coperchio	Tapa	-
2500-0010-0050-1020	1	15313	Bushing	Buchse	Bague	Boccola	Casquillo	1
2500-0010-0060	4	X2011575	Bolt 5/16 UNC	Schraube	Boulon	Bullone	Perno	-
2500-0010-0070	1	F91135	Washer spring retaining	Scheibe	Rondelle	Rosetta	Arandela	-
2500-0010-0080	1	F91136	Spring LRC	Feder	Ressort	Molla	Resorte	1
2500-0010-0090	1	F91154	Stop washer LRC	Scheibe	Rondelle	Rosetta	Arandela	-
2500-0010-0100	1	F91138	Collar LRC	Scheibe	Collier	Fascetto	Abrazadera	-
2500-0010-0110	1	F91141	Spiral pin 3/16"	Stift	Goupille	Alberino	Pasador	-
2500-0010-0120	1	2005000	Sleeve stop	Hülse-	Manchon-	Manicotto-	Casquillo	-
2500-0010-0130	1	F98457	Joint	Dichtung	Joint	Guarnizione	Junta	1
2500-0010-0140-1030	1	G36328	Outer housing	Gehäuse-	Carter-	Scatola-	Carcasa-	-
2500-0010-0140-1040	1	15313	Bushing	Buchse	Bague	Boccola	Casquillo	1
2500-0010-0140-1050	1	F98181	Oil Seal	Oldichtring	Joint d'étancheite	Tenuta olio	Reten aceite	1
2500-0010-0150	4	X2011575	Bolt 5/16" UNC	Schraube	Boulon	Bullone	Perno	-
2500-0010-0160	1	14975	Boot	Faltenblag	Manchon protecteur	Manicotto die gomma	Manilla de caucho	1
2500-0010-0170	1	F98430	Cable tie	Kabelklammer	Attache-cable	Fissaggio del cavo	Sujetcable	-
2500-0240	0	X10255	Bolt 3/8" UNF	Schraube	Boulon	Bullone	Perno	-
2500-0270	1	23605	Breather	Entlüfter	Reniflard	Sfiatatoi	Respiro	-