



# Spare Parts Catalog

9 S 1310 TO

Material number: 1324.001.098

ZF Friedrichshafen AG

Hauptverwaltung

80038 Friedrichshafen

Deutschland

Telefon: +49 7541 77-0

Telefax: +49 7541 77-908000

[www.zf.com](http://www.zf.com)

zuständiges Werk:

Friedrichshafen



Pos.	Information	Amendment number
001	Use case -----	
002	Customer KAMAZ PUBLIC JOINT STOCK COMPANY	
003	City Naberezhnye Chelny	
004	DUNS 64-493-2113	
005	Vehicle / Apparatus -----	
006	Sales Name	
007	Manufacturer KAMAZ PUBLIC JOINT STOCK COMPANY	
008	Engineering Name	
009	Product Use TRUCK	
010	Vehicle/Hardware Type ROAD TRACTOR	
011	SOP	
012	Engine	
013	Sales Designation	
014	Manufacturer Cummins Engine Co.	
015	Eng.Displ.	
016	Cylinder	
017	Nom. power 210 kW	
018	RPM at nom. power 2500 1/min	
019	Nom. torque 1020 Nm	
020	RPM at nom. torque 1500 1/min	
021	Classification use case -----	
022	DESIGNATION, CLUTCH MFZ430	
023	MANUFACTURER, CLUTCH ZF-SACHS	
024	TOTAL NUMBER OF WHEELS 6	
025	NUMBER OF DRIVING WHEELS 4	
026	DYNAMIC TYRE RADIUS 508 mm	
027	REAR AXLE RATIO 6.53	
031	PERMISS.GROSS VEHICLE WEIGHT 25 t	
032	PERMISS.GROSS COMBIN.WEIGHT 38 t	
033	APPROVAL NOTE 1 FIRST FITTING CHECK CARR.OUT	
034	Product description -----	
035	INSTALLATION POS TRANSMISSION HORIZONTAL LEFT	



Pos.	Information	Amendment number
036	TRANSMISSION ATTACHMENT FLANGE-MOUNTED	
037	RATIO, BOTTOM GEAR 9.48	
038	RATIO, TOP GEAR .75	
039	SET OF RATIOS TO	
040	RATIO, 1ST GEAR 9.48	
041	RATIO, 2ND GEAR 6.58	
042	RATIO, 3RD GEAR 4.68	
043	RATIO, 4TH GEAR 3.48	
044	RATIO, 5TH GEAR 2.62	
045	RATIO, 6TH GEAR 1.89	
046	RATIO, 7TH GEAR 1.35	
047	RATIO, 8TH GEAR 1	
048	RATIO, 9TH GEAR .75	
049	RATIO, 1ST GEAR REVERSE 8.97	
050	UEBERSETZUNG PLANETENSATZ 3.48	
051	NUMBER OF PLANETARY GEARS 4	
052	DESIGN, SHIFT SYSTEM TURNING SHAFT	
053	POSITION, GEAR SHIFT SYSTEM HORIZONTAL LEFT	
054	DESIGN, SHIFT PATTERN H-H	
056	VERSION TUBE R/C PLASTIC-FORM-PIPE	
059	DESIGN, SEPARATING CLUTCH FULL-SYNCHRONIZED	
062	REFERENCE LENGTH INPUT SHAFT 286 mm	
063	STANDARD TYPE INPUT SHAFT SAE	
064	NUMBER OF WEDGES INPUT SHAFT 10	
065	VERSION OF INPUT SHAFT FORM C	
066	NOMINAL DIAMETER INPUT SHAFT 1.75 in	
067	DIAMETER, JOURNAL, INPUT SHAFT 25 mm	
068	TYPE FIT SPIGOTS INPUT SHAFT F7	
069	DIAMETER SHAFT OF INPUT SHAFT 44 mm	
070	BUSH VARIANT INPUT SHAFT WITHOUT GROOVE	
071	DESIGN,CONN., CLUTCH HOUSING SAE 1	
075	DIAMETER, RELEASE FLANGE 60 mm	



Pos.	Information	Amendment number
076	TYPE FIT RELEASE BEARING FLA. E8	
077	DICHTKAPPE AUSRUECKLAGERFL y	
078	DESIGN BEARING OUTPUT STANDARD SUSPENSION	
079	OUTER DIA. OUTPUT FLANGE RA 180 mm	
080	NO.OF SCREWS OUTPUT FLANGE RA 4	
083	DIA. THREAD OUTPUT FL. SCR. RA M14	
084	REF. LENGTH OUTPUT FLANGE RA 103 mm	
085	THREAD PITCH OUTPUT FL SCR. RA 1.5 mm	
086	THREAD LENGTH OUTP.FL SCREW RA 50 mm	
087	DIMENSION SHIFT TURRET DIST. 229 mm	
088	MEAS. LOC. SHIFT TURRET DIST. SHIFT LEVER-LOCATION	
108	SPRING ARRANGEMENT Q2	
109	NORMENART HOHLFLANSCH HEXAGON SCREW	
110	TOOLING SET OF SPRINGS W308	
111	SPRING FORCE DETENT PLUNGER RG 153 N	
113	SPRING FORCE,GEAR DETENT NG+GG 200 N	
114	SELECTION PATTERN VARIANT GEAR SHIFT PATTERN 1	
117	SWITCH, REVERSE GEAR y	
118	DESIGN, RG (REV.GEAR) SWITCH CLOSING	
119	NOTE ON SWITCH, REVERSE GEAR GEAR SHIFT RAIL	
120	PROT. CAP SWITCH, REVERSE GEAR y	
121	DESIGN, CONNECTION, RG SWITCH BAYONET+PLUG	
123	SWITCH, NEUTRAL GEAR y	
124	DESIGN,NG(NEUTRAL GEAR)SWITCH OPENING SWITCH	
125	PROT.CAP SWITCH, NEUTRAL GEAR y	
126	DESIGN, CONNECTION, NG SWITCH BAYONET+PLUG	
128	FUNCTION OF R/C SWITCH GP	
129	DESIGN, GP SWITCH OPENING SWITCH	
130	PROTECTING CAP GP SWITCH y	
131	DESIGN, CONNECTION, GP SWITCH BAYONET+PLUG	
132	REF.LENGTH,RELEASE BEAR.FLAN 170 mm	
134	ATTACHED AGRREGATES 1 WITHOUT WSK	



Pos.	Information	Amendment number
135	ATTACHM.POS.HEAT EXCHANGER WITHOUT GROOVE	
136	VER. TRANSMISSION VENTILATION BREATHER	
139	ATTACHMENT VARIANT, RETARDER WITHOUT GROOVE	
140	LENGTH CLUTCH HOUSING 174 mm	
142	TYPE OF RELEASE MECHANISM PULLED	
143	VERSION OF CLUTCH CYLINDER SERVO	
144	DIAMETER, CLUTCH CYLINDER 100 mm	
145	ASSEMBLY POS. CLUTCH CYLINDER 6	
146	LENGTH TAPPET CLUTCH CYLINDER 127 mm	
147	DESIGN LUBRI.CONN. REL.BEARING WITHOUT GROOVE	
148	THREAD DIA. MTG BOLT SUSPENSION M16	
151	THREAD PITCH SUSPENSION 2 mm	
152	DESIGN WEAR INDICATOR CLUTCH WITHOUT GROOVE	
153	DESIGN SWITCH CLUTCH PREPARED	
158	OUTER DIAMETER RELEASE BEARING 60 mm	
160	WRENCH SIZE, RELEASE FORK 128 mm	
161	LENGTH, RELEASE BEARING 82 mm	
163	DESIGN PULSE SENSOR INPUT WITHOUT GROOVE	
165	PROT.CAP PULSE SENSOR INPUT n	
167	NO. PULSES PULSE SENSOR SFAH68 8 IMP/U	
169	VERSION PULSE SENSOR SFA H68 WITH	
171	PROT. CAP PULSE SENSOR SFA H68 y	
185	NOTE ON OIL FILL FILL IN OVERFLOW	
186	POSITION, OIL FILLER HOUSING, LH SIDE	
187	OIL CAPACITY, GEARBOX 8.900 dm3	
188	OIL FILL VARIANT EX WORKS	
189	OIL GRADE PERMISSIBLE ACC. TO TE-ML02	
191	COLOR JET BLACK	
192	COLOUR CLASSIFICATION ACC. TO RAL 9005	
193	PAINTING, ZF STANDARD 915 W	
194	CODING OUTER CONSERVATION KA1	
195	SCOPE OUTER CONSERVATION T	



Pos.	Information	Amendment number
196	CODING INNER CONSERVATION KI1	
197	CONSERVATION SPECIFICATION ZFN 916	
198	CODIERUNG STOPFENANZAHL	
199	Documents -----	
200	Checkliste_CKD Text-document 1324.199.004	
201	TURN.SHAFT CONT Drawing 1324.149.004	
202	TURN.SHAFT CONT Assembly 1324.149.004	
203	9-SPEED GEARBOX Drawing 1324.001.042	
204	9-SPEED GEARBOX Assembly 1324.001.042	
205	GEARSHIFT SYST. Drawing 1324.172.009	
206	GEARSHIFT SYST. Assembly 1324.172.009	
207	9-SPEED GEARBOX Drawing 1324.601.016	
208	KUPPLUNGSGLOCKE Drawing 6060.000.001	
209	CLUTCH HOUSING Drawing 6060.600.029	
210	9-SPEED GEARBOX Assembly 1324.601.016	

# Assembly group overview

Material number: 1324.001.098

9 S 1310 TO /



Page 1 from 2

Graphics	Pos.	Material number	Name	Quantity	Amend. no.	Techn. Info.
062.01.15-1	110	1324.101.038	GEARBOX HOUSING	1		
062.01.82-1	120	1324.101.801	GEARBOX HOUSING	1		
062.01.90-1	122	1304.101.800	CLOSING COMPONENTS	1		
062.02.40-1	140	1304.102.455	CONNPLATE	1		
062.02.81-1	150	1324.102.802	INPUT SHAFT	1		
062.02.10-1	910	1324.102.011	INPUT SHAFT	1		
062.03.81-1	180	1324.103.801	LAYSHAFT	1		
062.03.07-1	920	1324.103.006	LAYSHAFT	1		
062.04.08-1	930	1324.104.007	MAIN SHAFT	1		
062.06.27-1	230	1324.106.004	GEAR SHIFT SYSTEM	1		
062.06.50-1	238	1324.106.412	CONNECTING PARTS	1		
062.07.85-1	282	1324.107.800	GEAR SHIFT HOUSING	1		
062.07.15-1	910	1324.107.006	GEAR SHIFT HOUSING	1		
062.07.58-1	914	1324.107.408	GEAR SHIFT SHAFT	1		
062.08.22-1	930	1324.170.011	COVER	1		
062.08.85-1	934	1324.170.809	COVER	1		
062.12.29-1	922	1324.149.026	SET OF SPRINGS	1		
062.43.09-1	20	1304.131.069	GP HOUSING	1		
062.43.40-1	30	1304.131.400	CLOSING COMPONENTS	1		
062.43.09-1	512	1324.131.800	HOUSING GP	1		
062.44.13-1	40	1324.132.003	PLANETARY DRIVE	1		
062.44.59-1	50	1324.132.403	PLANETARY DRIVE	1		
062.44.13-1	60	1324.132.800	PLANETARY DRIVE	1		
062.45.05-1	70	1324.133.001	SYNCHRONIZER	1		
062.45.05-1	80	1304.133.404	SYNCHRONIZER	1		
062.46.09-1	90	1324.134.004	GP SHIFT SYSTEM	1		
062.46.40-1	554	1304.134.413	CONNECTING PARTS	1		
062.47.02-1	190	1304.135.014	SPEEDOMETER COVER	1		
062.47.02-1	194	1304.135.803	SPEEDOMETER COVER	1		
062.57.02-1	390	1324.145.015	RANGE SELECTION	1		
061.92.78-1	480	6060.101.840	ANCHORAGE	1		

# Assembly group overview

Material number: 1324.001.098

9 S 1310 TO /

Page 2 from 2



Graphics	Pos.	Material number	Name	Quantity	Amend. no.	Techn. Info.
061.92.27-1	900	6060.101.692	CLUTCH HOUSING	1		
061.92.27-1	920	6060.101.877	ANCHORAGE	1		
061.93.30-1	910	6060.168.001	CLUTCH RELEASE DEVICE	1		



# Plant

Page 1 from 3

Material number: 1324.001.098  
Plant: 062.01.15-1  
GEARBOX HOUSING

9 S 1310 TO /  
GEARBOX HOUSING

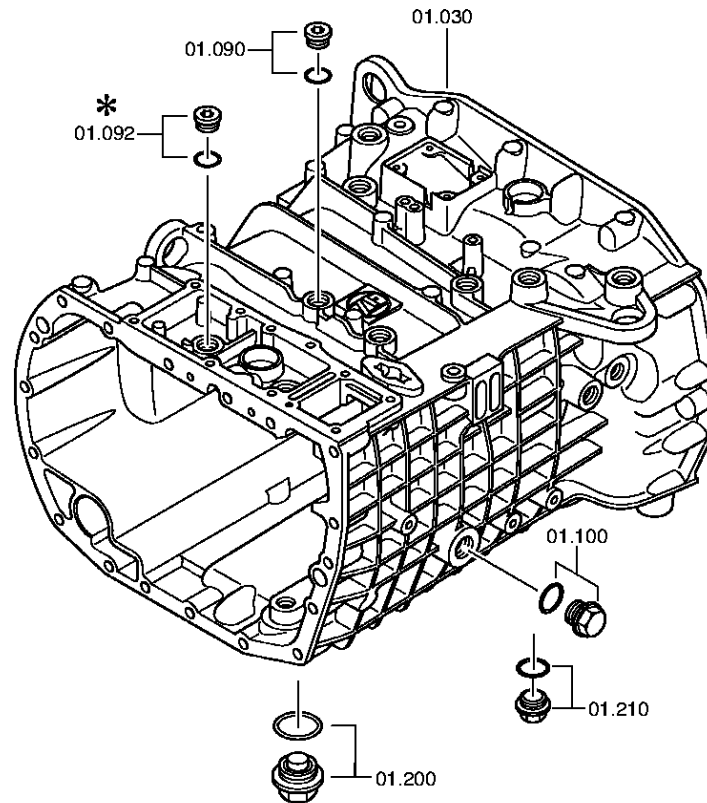

# Plant

Page 2 from 3

Material number: 1324.001.098  
Plant: 062.01.82-1  
GEARBOX HOUSING

9 S 1310 TO /  
GEARBOX HOUSING

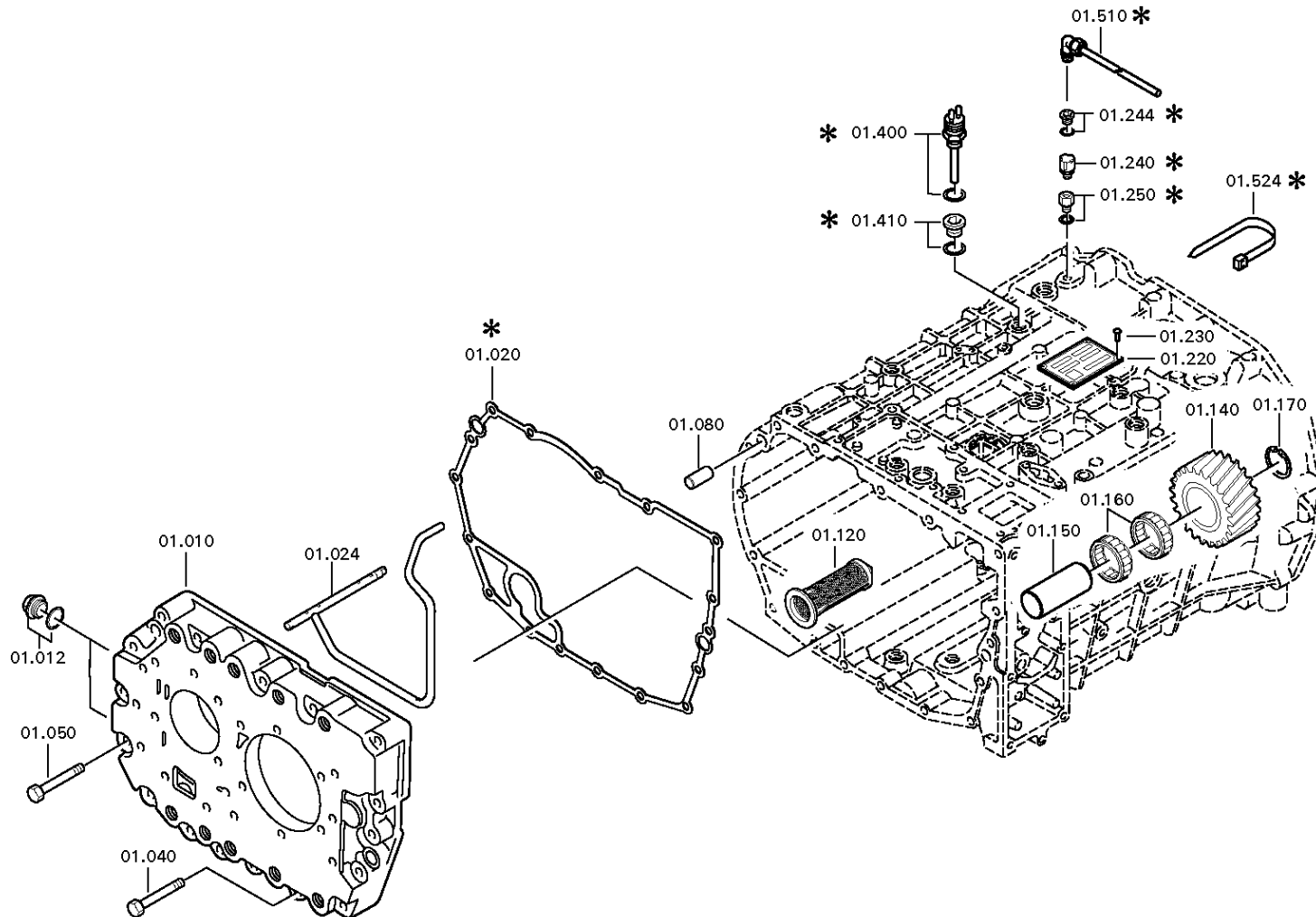

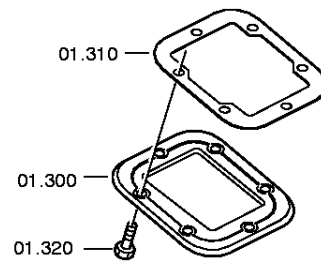
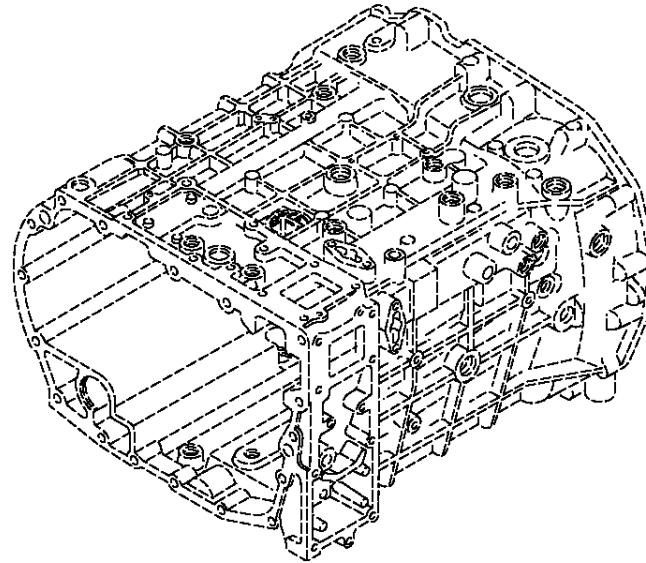

# Parts list

Page 1 from 2

Material number: 1324.001.098

9 S 1310 TO /

Plant: 062.01.15-1

Material-assembly-group-no: 1324.101.038



Pos.	Material number	Customer material	Name	Quantity	ME	Amend. no.	Techn. Info.	Weight	Rep kit	Alternative material
10	1324.301.119		HOUSING I	1		C01005748F10	9S1110/1310, 8S2100	0,000		
12	---		SCREW PLUG	2			45N.M*DICHTRING M16X1,5	0,000		
---	0636.100.794		SCREW PLUG	2		Z00010111711	M16X1,5	0,000		
---	0634.801.044		SEALING RING	2			16X20	0,010		
20	0501.321.065		GASKET	1				0,000		
24	1324.201.019		PIPE	1			KPL.SPRITZROHR UNTENLIEG.	0,000		
30	1324.201.041		HOUSING	1			KPL.	0,000		
40	0736.300.123	1880233	HEXAGON BOLT	3			M10X70 M10X70	0,000		
50	0736.300.123	1880233	HEXAGON BOLT	14			M10X70 M10X70	0,000		
80	0631.306.229		CYLINDRICAL PIN	2			16X36	0,000		
90	---		SCREW PLUG	1		Z00010111513	35N.M*DICHTRING M18X1,5	0,000		
---	0636.100.791		SCREW PLUG	1		Z00010111521	M18X1,5	0,000		
---	0634.801.062		SEALING RING	1		Z00010111521	18X24	0,001		
100	---		SCREW PLUG	1		Z00010112111	60N.M*DICHTRING M24X1,5	0,000		
---	0636.304.088		SCREW PLUG	1		Z00010112110	M24X1,5	0,000		
---	0730.008.637		SEALING RING	1		Z00010112110	A24X29	0,000		
120	0501.318.802	5718 742 08	SCREEN INSERT	1				0,000		
140	1324.305.001		REVERSE IDLER GEAR	1		Z00003789910	9S1110/9S1310	0,000		
150	1304.305.030		PIN	1				0,000		
160	0750.115.974		ROLLER CAGE	2		C01004483F10	40,0X60,0X26,0	0,000		
/10	0735.358.192	8204001530	ROLLER CAGE	1			40,0X60,0X26,0 FA.INA	0,000		
/20	0735.358.338		NEEDLE SLEEVE	1			40,0X60,0X26,0 FA.NRB	0,000		
170	0630.502.022		RETAINING RING	1			40X1,75	4,800		
200	---		SCREW PLUG	1		Z00010112212	M38X1,5	0,000		
---	0736.300.272		SCREW PLUG	1		Z00010112215	M38X1,5	0,000		
---	0634.801.321	190003098138	SEALING RING	1		Z00010112215	38X44	0,001		

# Parts list

Page 2 from 2

Material number: 1324.001.098

9 S 1310 TO /

Plant: 062.01.15-1

Material-assembly-group-no: 1324.101.038



Pos.	Material number	Customer material	Name	Quantity	ME	Amend. no.	Techn. Info.	Weight	Rep kit	Alternative material
210	---		SCREW PLUG	1		Z00010112111	60N.M*DICHTRING M24X1,5	0,000		
---	0636.304.088		SCREW PLUG	1		Z00010112110	M24X1,5	0,000		
---	0730.008.637		SEALING RING	1		Z00010112110	A24X29	0,000		
220	---		TYPE PLATE	1			BOUTHEON	0,000		
---	0730.365.241		TYPE PLATE	1		C01001056E10	EINHEITSSCH. VERDREHSICHER	0,000		
---	0730.365.246		TYPE PLATE	1		C01004699E10	EINHEITSSCH. VERDREHSICHER	0,000		
230	0731.300.027		BLIND RIVET	4		Z00007904810		0,000		
240	---		BREATHER	1			M10X1KEG	0,000		
---	0501.218.540		BREATHER	1				0,000		
300	1324.301.165		COVER	1		Z00009633112		0,000		
310	1290.301.140		GASKET	1			ENTHALT.IN 1290 301 071(1)	0,000		
320	0636.016.403		HEXAGON BOLT	6		Z00007058114	M10X22	0,000		

# Plant

Page 1 from 3

Material number: 1324.001.098  
Plant: 062.02.40-1  
INPUT SHAFT

9 S 1310 TO /  
CONNPLATE

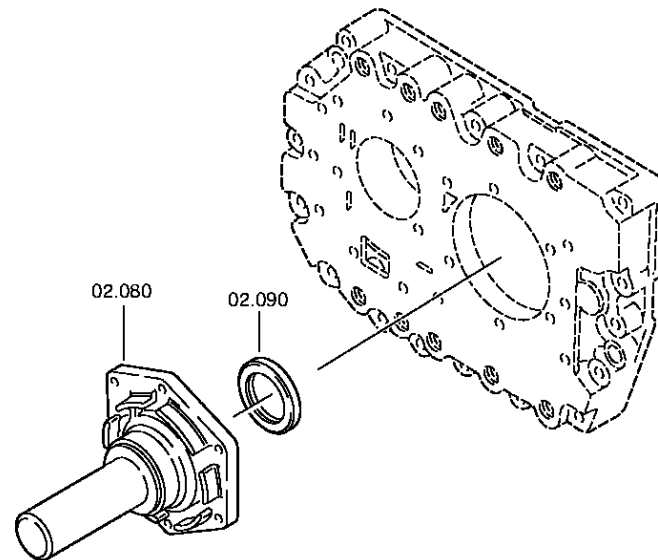

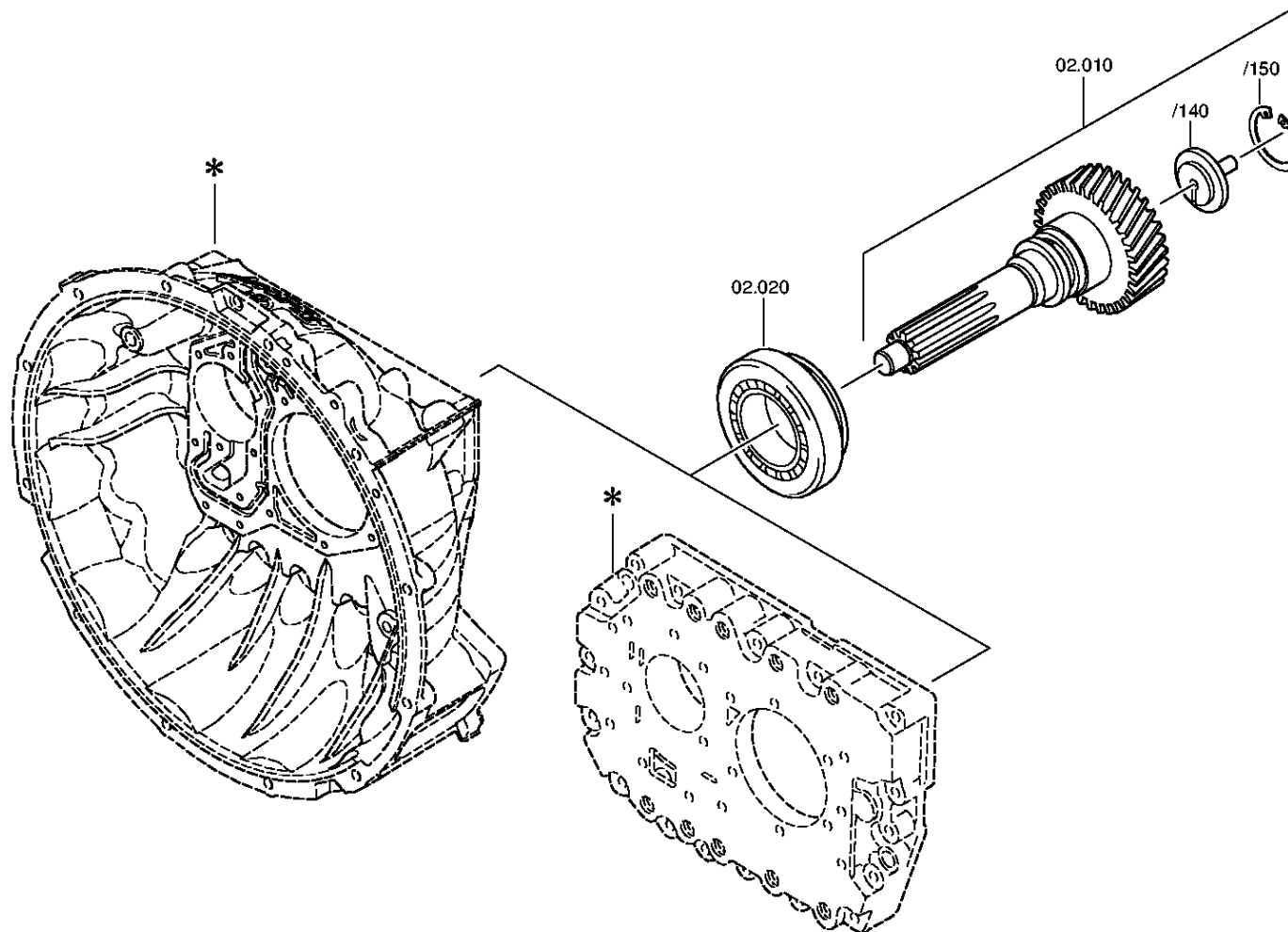

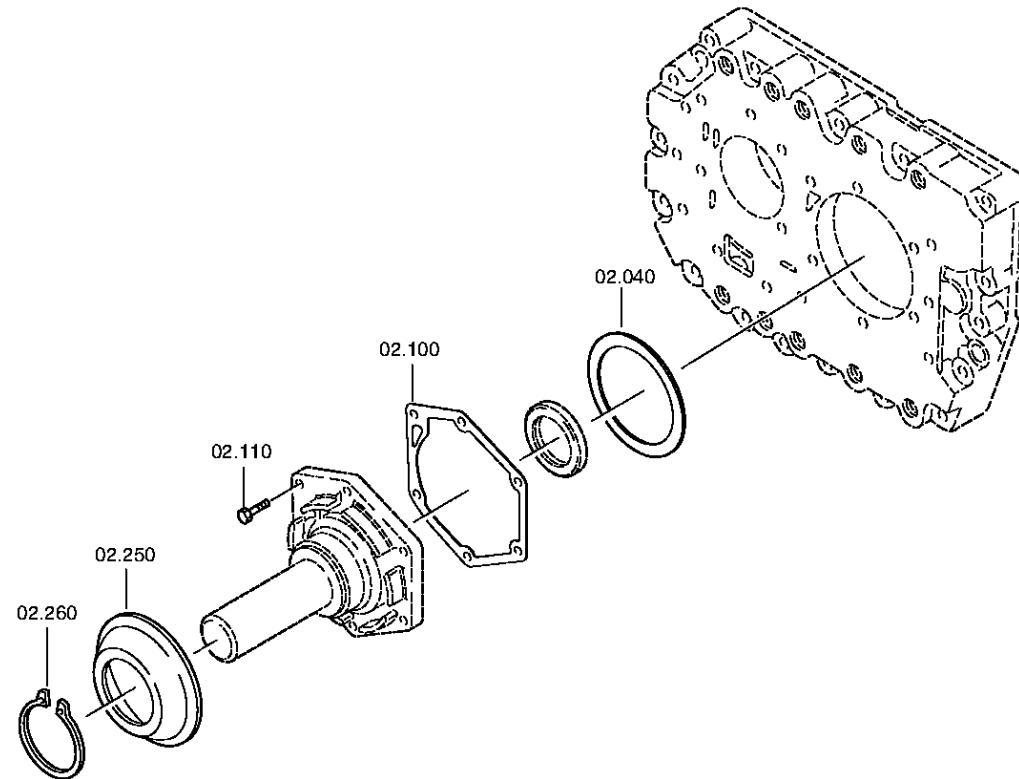



# Parts list

Page 1 from 2

Material number: 1324.001.098

9 S 1310 TO /

Plant: 062.02.40-1

Material-assembly-group-no: 1304.102.455



Pos.	Material number	Customer material	Name	Quantity	ME	Amend. no.	Techn. Info.	Weight	Rep kit	Alternative material
10	1324.202.014		INPUT SHAFT	1			KPL.	0,000		
/140	1304.302.440	1332980400	COVER	1				0,000		
/150	0630.502.063	934443R1	RETAINING RING	1			58X2	10,400		
20	0750.117.518	5 8104 0	TAROLLBEARING	1			71,4X120,0X32,5	0,000		
40	---		SHIM	1			S= 1,30- 2,30( ABSTUFUNG:0,05MM)	0,000		
---	0730.005.857		SHIM	1			A=2,30 IN 0730 006 163(2)	0,000		
---	0730.005.856		SHIM	1			A=2,25 IN 0730 006 163(2)	0,000		
---	0730.006.184		SHIM	1			A=2,20 IN 0730 006 163(2)	0,000		
---	0730.006.183		SHIM	1			A=2,15 IN 0730 006 163(2)	0,000		
---	0730.006.182		SHIM	1			A=2,10 IN 0730 006 163(2)	0,000		
---	0730.006.181		SHIM	1			A=2,05 IN 0730 006 163(2)	0,000		
---	0730.006.180		SHIM	1			A=2,00 IN 0730 006 163(2)	0,000		
---	0730.006.179		SHIM	1			A=1,95 IN 0730 006 163(2)	0,000		
---	0730.006.169		SHIM	1			A=1,90 IN 0730 006 163(2)	0,000		
---	0730.006.168		SHIM	1			A=1,85 IN 0730 006 163(2)	0,000		
---	0730.002.654	1000000468	SHIM	1				47		
---	0730.006.167		SHIM	1			A=1,75 IN 0730 006 163(2)	0,000		
---	0730.002.655	1000000469	SHIM	1				0,040		
---	0730.006.166		SHIM	1			A=1,65 IN 0730 006 163(2)	0,000		

# Parts list

Page 2 from 2

Material number: 1324.001.098

9 S 1310 TO /

Plant: 062.02.40-1

Material-assembly-group-no: 1304.102.455



Pos.	Material number	Customer material	Name	Quantity	ME	Amend. no.	Techn. Info.	Weight	Rep kit	Alternative material
---	0730.002.656	1000000470	SHIM	1				43		
---	0730.006.165	8900126818	SHIM	1				40		
---	0730.002.657	1000000471	SHIM	1				39		
---	0730.006.164	504591	SHIM	1				37		
---	0730.002.658	SA 8320-04820	SHIM	1				0,030		
---	0730.007.640	8900126821	SHIM	1				35		
---	0730.002.659	SA 8320-04830	SHIM	1				29		
80	1304.302.350		CONNPLATE	1			ENTHALT.IN 1304 302 347(0)	0,000		
90	0734.310.104	8 8281 0	SHAFT SEAL	1			52X68X8 FA.CFW	0,000		
100	0501.322.828		GASKET	1		C01005749F10		0,000		
110	0636.100.797		HEXAGON BOLT	6		Z00007891312	M8X30	0,000		
250	1324.302.191		SEALING CAP	1				0,000		
260	0630.501.051		RETAINING RING	1			82X2,5	28		

# Plant

Page 1 from 2

Material number: 1324.001.098  
Plant: 062.03.81-1  
LAYSHAFT

9 S 1310 TO /  
LAYSHAFT

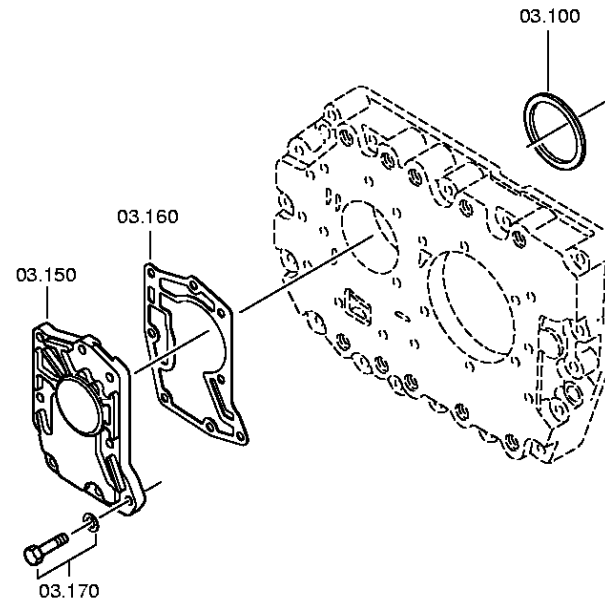

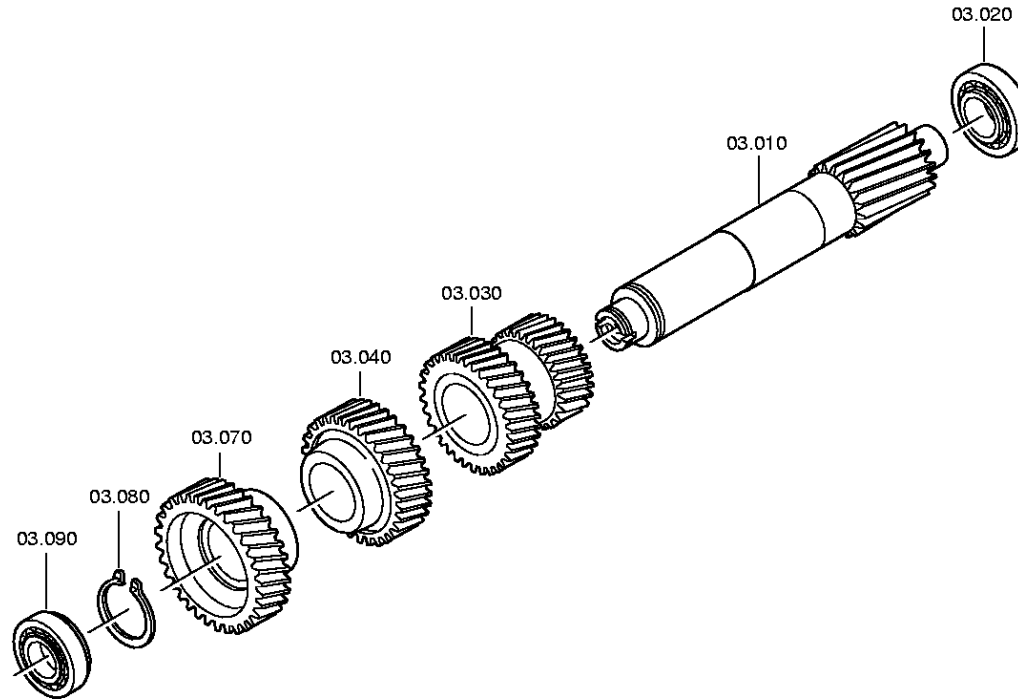

# Parts list

Page 1 from 2

Material number: 1324.001.098

9 S 1310 TO /

Plant: 062.03.81-1

Material-assembly-group-no: 1324.103.801



Pos.	Material number	Customer material	Name	Quantity	ME	Amend. no.	Techn. Info.	Weight	Rep kit	Alternative material
10	1324.303.001		LAYSHAFT	1				0,000		
20	0750.117.083	8504001600	TAROLLBEARING	1			50,8X95,2X27,7	0,000		
30	1324.303.015		DOUBLE GEAR	1			1/2G	0,000		
40	1324.303.003		HELICAL GEAR	1			4G	0,000		
70	1324.303.004		HELICAL GEAR	1			KONST.	0,000		
80	---		RETAINING RING	1			S= 2,00- 2,60( ABSTUFUNG:0,10MM)	0,000		
---	0630.300.508		RETAINING RING	1			58X2,6	0,000		
---	0630.501.073		RETAINING RING	1			58X2,5	0,000		
---	0630.501.074		RETAINING RING	1			58X2,4	0,000		
---	0630.501.076		RETAINING RING	1			58X2,3	0,000		
---	0630.501.104		RETAINING RING	1			58X2,2	0,000		
---	0630.501.140		RETAINING RING	1			58X2,1	0,000		
---	0630.501.040	1239967	RETAINING RING	1			58X2	11		
90	0750.117.881		TAROLLBEARING	1		C01009457E10	40,0X85,0X33,0	0,000		
/10	0735.371.096	5 8122 0	TAROLLBEARING	1			40,0X85,0X33,0 FA.SKF	0,000		
/20	0735.371.117		TAROLLBEARING	1			40,0X85,0X33,0 FA.FAG	0,000		
100	---		SHIM	1		Z00013179811	S= 1,50- 2,40( ABSTUFUNG:0,05MM)	0,000		
---	0730.003.436		SHIM	1			A=2,40	0,000		
---	0730.004.737		SHIM	1			A=2,35	0,000		
---	0730.004.736		SHIM	1			A=2,30	0,000		
---	0730.004.735		SHIM	1			A=2,25	0,000		
---	0730.004.734		SHIM	1			A=2,20	0,000		
---	0730.004.733		SHIM	1			A=2,15	0,000		
---	0730.004.732		SHIM	1			A=2,10	0,000		
---	0730.004.731		SHIM	1			A=2,05	0,000		
---	0730.002.934		SHIM	1			A=2,00	0,000		
---	0730.003.435		SHIM	1			A=1,95	0,000		
---	0730.002.935		SHIM	1			A=1,90	0,000		
---	0730.003.434		SHIM	1			A=1,85	0,000		

# Parts list

Page 2 from 2

Material number: 1324.001.098

9 S 1310 TO /

Plant: 062.03.81-1

Material-assembly-group-no: 1324.103.801



Pos.	Material number	Customer material	Name	Quantity	ME	Amend. no.	Techn. Info.	Weight	Rep kit	Alternative material
---	0730.002.936		SHIM	1			A=1,80	0,000		
---	0730.003.433		SHIM	1			A=1,75	0,000		
---	0730.002.937		SHIM	1			A=1,70	0,000		
---	0730.003.432		SHIM	1			A=1,65	0,000		
---	0730.002.938		SHIM	1			A=1,60	0,000		
---	0730.003.431		SHIM	1			A=1,55	0,000		
---	0730.002.939		SHIM	1			A=1,50	0,000		
150	---		PUMP	1		Z00013179811		0,000		
---	0501.215.228		PUMP	1			KPL.	0,000		
---	0501.215.245		OIL PUMP	1			KPL.F.SEP.KUPPL. GLOCKE E21	0,000		
160	0501.322.829		GASKET	1		Z00013179811		0,000		
170	---		HEXAGON BOLT	8		Z00013179811	M8X30	0,000		
---	0636.100.797		HEXAGON BOLT	8		Z00007891310	M8X30	0,000		
---	0630.100.295		WASHER	8		Z00007158414		0,000		

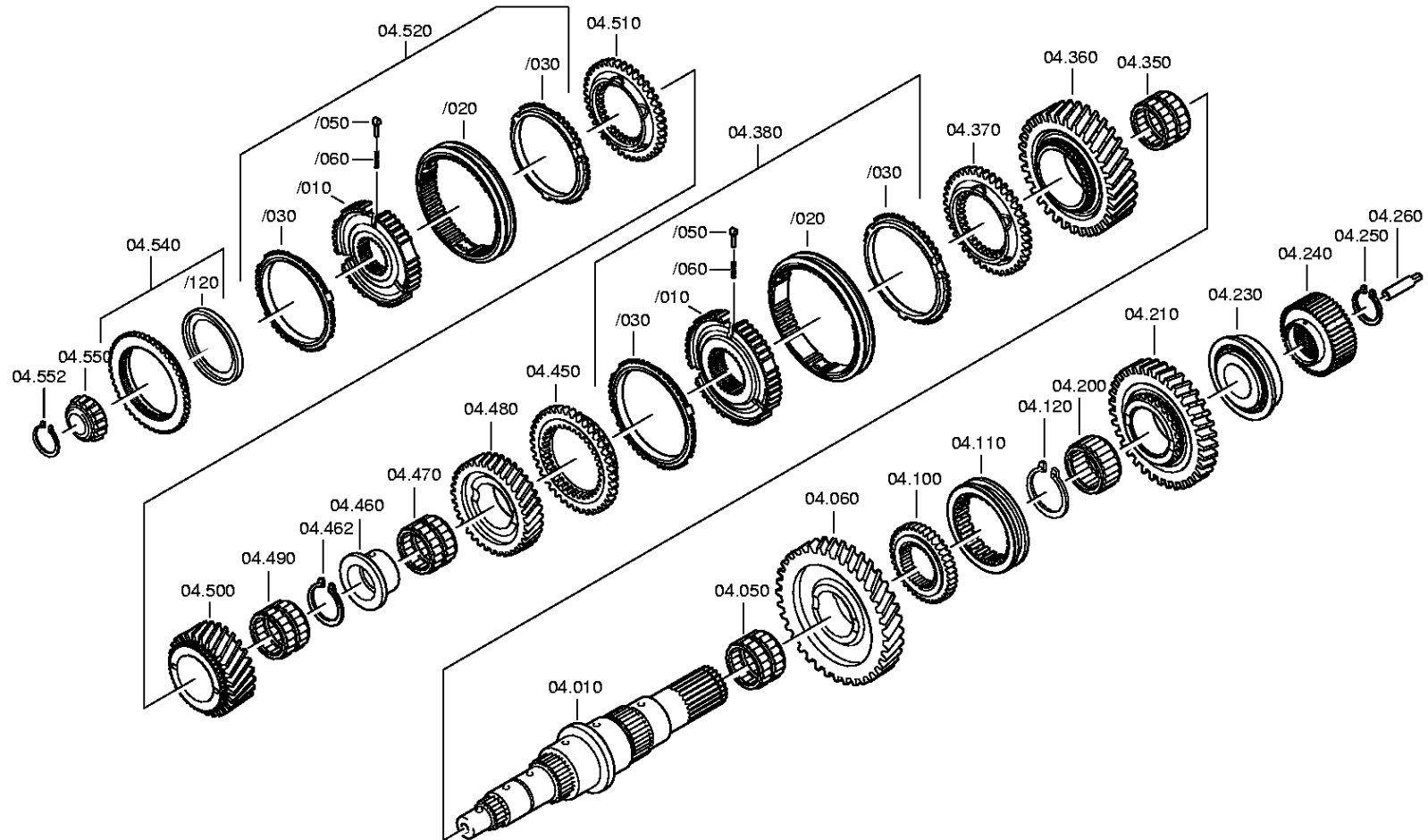

# Parts list

Page 1 from 3

Material number: 1324.001.098

9 S 1310 TO /

Plant: 062.04.08-1

Material-assembly-group-no: 1324.104.007



Pos.	Material number	Customer material	Name	Quantity	ME	Amend. no.	Techn. Info.	Weight	Rep kit	Alternative material
10	1324.304.005		MAIN SHAFT	1			E21	0,000		
50	0750.115.972		NEEDLE CAGE	1		C01004478F10	CR 75,0X83,0X35,0	0,000		
/10	0735.320.500	820-400-1650	NEEDLE CAGE	1			75,0X83,0X35,0	0,180		
/20	0735.321.683		NEEDLE CAGE	1			75,0X83,0X35,0 FA.NRB	0,000		
60	1304.304.543		HELICAL GEAR	1			ENTHALT.IN 1304 304 425(0)	0,000		
100	1324.304.037		SLEEVE CARRIER	1				0,000		
110	1304.304.444	1334213210	SLIDING SLEEVE	1			9S-109 KLAUE D=96	0,000		
120	---		RETAINING RING	1			S= 2,40- 2,80( ABSTUFUNG:0,10MM)	0,000		
---	0630.501.195		RETAINING RING	1			60X2,8	0,000		
---	0630.501.194		RETAINING RING	1			60X2,7	0,000		
---	0630.501.197	092-953-6042	RETAINING RING	1			60X2,6	0,000		
---	0630.531.141	092-953-6041	RETAINING RING	1			60X2,5	0,000		
---	0630.501.067	0929536040	RETAINING RING	1			60X2,4	0,000		
200	0750.115.973		NEEDLE CAGE	1		C01004479F10	60,0X68,0X39,0	0,000		
210	1324.304.021		HELICAL GEAR	1		Z00003789910	RG 9S1110/9S1310	0,000		
230	0750.117.844		TAROLLBEARING	1			50,8X104,7X36,5	0,000		
/10	0735.371.599	5 8098 0	TAROLLBEARING	1			50,8X104,7X36,5 FA.TIMKEN	0,000		
/20	0735.372.146		TAROLLBEARING	1			50,8X104,7X36,5 FA.FAG	0,000		
240	1324.304.028		SUN GEAR	1		C01006561F10	9 S 1310 TO	0,000		
250	---		RETAINING RING	1			S= 2,10- 3,20( ABSTUFUNG:0,05MM)	0,000		
---	0630.501.151	0002640851	RETAINING RING	1			50X3,2	0,000		
---	0630.501.298		RETAINING RING	1			50X3,15	0,000		
---	0630.501.150	0002640751	RETAINING RING	1			50X3,1	0,000		
---	0630.501.299		RETAINING RING	1			50X3,05	0,000		
---	0630.531.065	VOE12743111	RETAINING RING	1			50X3	16		
---	0630.501.111		RETAINING RING	1			50X2,95	0,000		



# Parts list

Page 2 from 3

Material number: 1324.001.098

9 S 1310 TO /

Plant: 062.04.08-1

Material-assembly-group-no: 1324.104.007



Pos.	Material number	Customer material	Name	Quantity	ME	Amend. no.	Techn. Info.	Weight	Rep kit	Alternative material
---	0630.501.112	0002640551	RETAINING RING	1			50X2,9	0,000		
---	0630.501.113		RETAINING RING	1			50X2,85	0,000		
---	0630.501.114	5004853	RETAINING RING	1			50X2,8	0,000		
---	0630.501.115		RETAINING RING	1			50X2,75	0,000		
---	0630.501.116	5004854	RETAINING RING	1			50X2,7	0,000		
---	0630.501.117		RETAINING RING	1			50X2,65	0,000		
---	0630.501.118	0002641251	RETAINING RING	1			50X2,6	0,000		
---	0630.501.160		RETAINING RING	1			50X2,55	0,000		
---	0630.531.064	1663657	RETAINING RING	1			50X2,5	0,100		
---	0630.501.159		RETAINING RING	1			50X2,45	0,000		
---	0630.501.148	0002641051	RETAINING RING	1			50X2,4	0,000		
---	0630.501.294		RETAINING RING	1			50X2,35	0,000		
---	0630.501.147	0002640951	RETAINING RING	1			50X2,3	0,000		
---	0630.501.295		RETAINING RING	1			50X2,25	0,000		
---	0630.501.146	0929534731	RETAINING RING	1			50X2,2	0,000		
---	0630.501.296		RETAINING RING	1			50X2,15	0,000		
---	0630.501.145	5005497	RETAINING RING	1			50X2,1	0,000		
260	1324.304.014		PIPE	1			E21	0,000		
350	0750.115.971		NEEDLE CAGE	2		C01004480F10	1G 75,0X83,0X23,0	0,000		
360	1324.304.030	42562338	HELICAL GEAR	1		Z00004550510	KLAUE D=100	0,000		
370	1324.304.013		CLUTCH BODY	1			ZF BK131_O	0,000		
380	1324.204.007		SYNCHRONIZER	1			KPL.1+2G	0,000		
/10	1324.304.052		SYNCHROBODY	1		Z00005741711	ZF-BK131	0,000		
/20	1324.304.053		SLIDING SLEEVE	1		Z00005741711	ZF-BK131 ECOMID 1./2. SAMM	0,000		
/30	1268.304.594	5 5290 0	SYNCHRONING	2			ZFBK 131	0,000		
/50	1297.304.436		PRESSURE PIECE	3				0,004		
/60	0732.040.409		COMPRSPRING	3		C01007317F10		0,002		
450	1324.304.013		CLUTCH BODY	1			ZF BK131_O	0,000		
460	1324.304.064		BUSH	1		Z00012143410		0,000		

# Parts list

Page 3 from 3

Material number: 1324.001.098

9 S 1310 TO /

Plant: 062.04.08-1

Material-assembly-group-no: 1324.104.007



Pos.	Material number	Customer material	Name	Quantity	ME	Amend. no.	Techn. Info.	Weight	Rep kit	Alternative material
462	---		RETAINING RING	1			S= 1,90- 2,40( ABSTUFUNG:0,10MM)	0,000		
---	0630.501.067	0929536040	RETAINING RING	1			60X2,4	0,000		
---	0630.501.068		RETAINING RING	1			60X2,3	0,000		
---	0630.501.069	0929536046	RETAINING RING	1			60X2,2	0,000		
---	0630.501.070	092-953-6047	RETAINING RING	1			60X2,1	0,000		
---	0630.501.041		RETAINING RING	1			60X2	0,010		
---	0630.501.278		RETAINING RING	1			60X1,9	0,000		
470	0750.115.970		NEEDLE CAGE	1		C01004481F10	75,0X83,0X40,0	0,000		
480	1324.304.015		HELICAL GEAR	1			2G	0,000		
490	0750.115.969		NEEDLE CAGE	2		C01004482F10	60,0X68,0X25,0	0,000		
500	1324.304.003	1788065	HELICAL GEAR	1			4G	0,000		
510	1324.304.011		CLUTCH BODY	1				0,000		
520	1324.204.008		SYNCHRONIZER	1			KPL.3+4G	0,000		
/10	1324.304.006		SYNCHROBODY	1			E21 IN 1304 304 650(0)	0,000		
/20	1311.304.103		SLIDING SLEEVE	1			ZF-BK119	0,000		
/30	1311.304.255	5 5324 0	SYNCHRO RING	2			ZF BK119	0,000		
/50	1297.304.436		PRESSURE PIECE	3				0,004		
/60	0732.040.409		COMPRSPRING	3		C01007317F10		0,002		
540	1324.204.009		CLUTCH BODY	1			KPL.	0,000		
/120	0501.314.108	5 6044 0	OIL DAM	1			79X105,1X5,3*CFW	0,000		
550	0750.117.232	820-400-2650	TAROLLBEARING	1			42,0X40,3	0,000		
552	---		RETAINING RING	1			S= 2,00- 2,50( ABSTUFUNG:0,10MM)	0,000		
---	0630.531.052	58-023-630531052	RETAINING RING	1			42X2,5	10		
---	0630.501.120		RETAINING RING	1			42X2,4	0,000		
---	0630.501.156		RETAINING RING	1			42X2,3	0,000		
---	0630.501.210		RETAINING RING	1			42X2,2	0,000		
---	0630.501.208		RETAINING RING	1			42X2,1	0,000		
---	0630.501.157		RETAINING RING	1			42X2,0	0,000		

# Plant

Page 1 from 2

Material number: 1324.001.098  
Plant: 062.06.27-1  
GEAR SHIFT SYSTEM

9 S 1310 TO /  
GEAR SHIFT SYSTEM

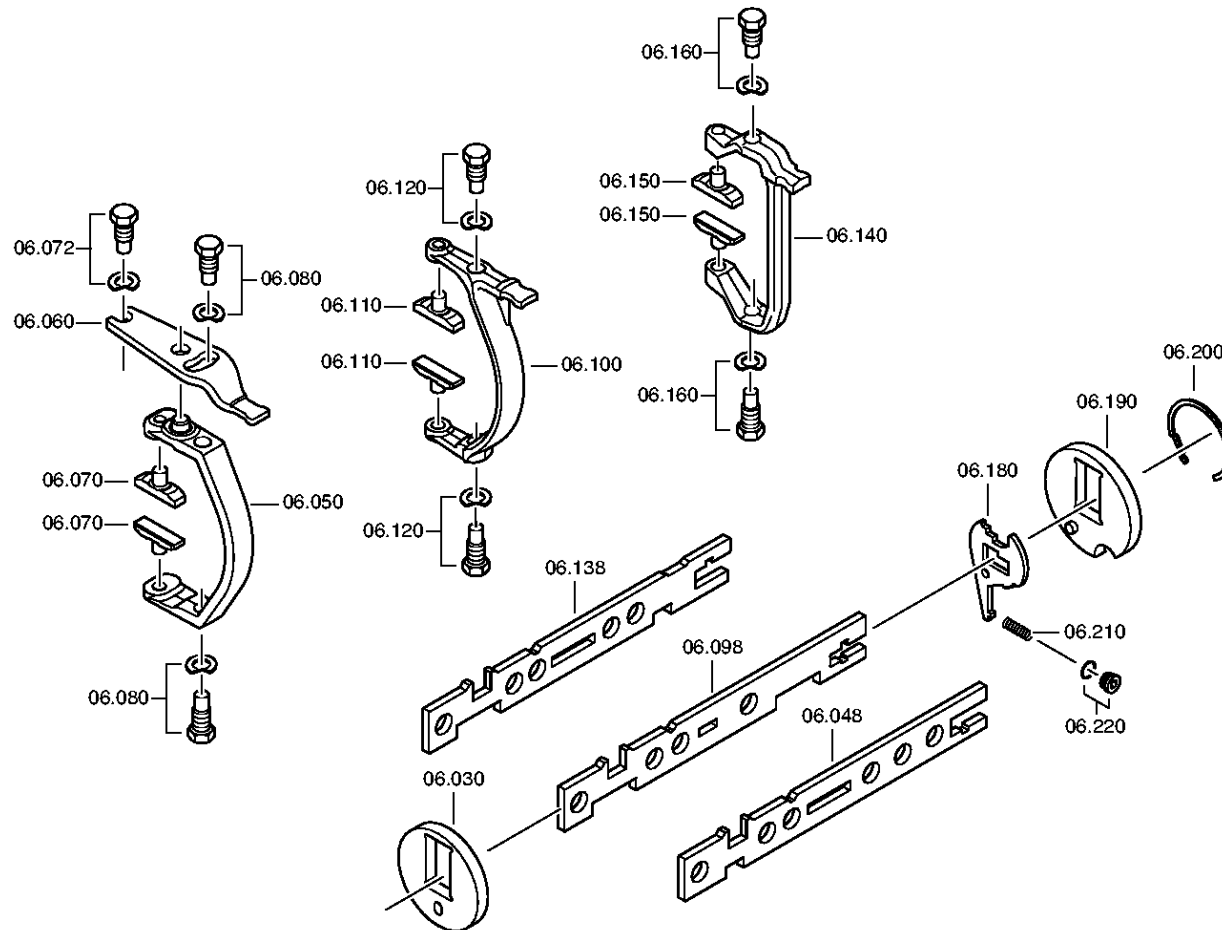

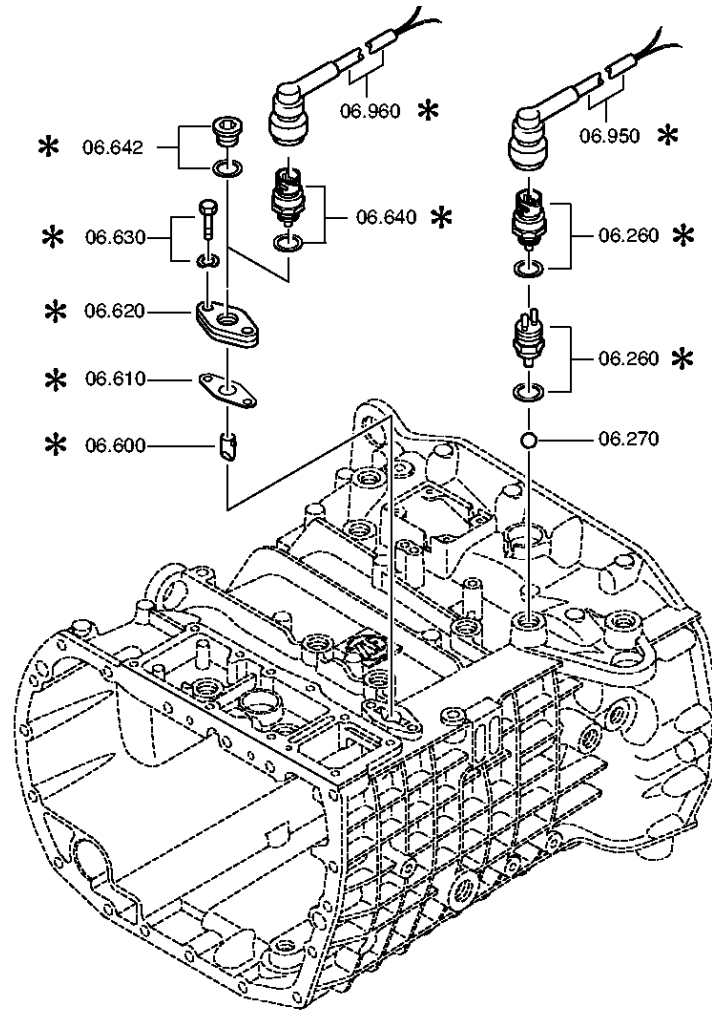

# Parts list

Page 1 from 2

Material number: 1324.001.098

9 S 1310 TO /

Plant: 062.06.27-1

Material-assembly-group-no: 1324.106.004



Pos.	Material number	Customer material	Name	Quantity	ME	Amend. no.	Techn. Info.	Weight	Rep kit	Alternative material
30	1304.306.089		BEARING PLATE	1				0,000		
48	1324.306.027		GEAR SHIFT RAIL	1		C01003687E10	3/4	0,000		
50	1324.306.031		GEAR SHIFT FORK	1		C01003687E10	3/4 WITH TOGGEL	0,000		
60	1324.306.040		RELAY LEVER	1				0,000		
70	1304.306.107		SLIDING PAD	2		C01005039E10		0,000		
72	---		ARTICULATION BOLT	1			M18X1,5 SK6	0,000		
---	1346.306.089		ARTICULATION BOLT	1		Z00008927910		0,000		
---	0730.301.379	1882879	SPRING WASHER	1		Z00009160711	19X28 19X28	0,000		
80	---		ARTICULATION BOLT	2			M18X1,5 SK6	0,000		
---	1346.306.089		ARTICULATION BOLT	2		Z00008927910		0,000		
---	0730.301.379	1882879	SPRING WASHER	2		Z00009160711	19X28 19X28	0,000		
98	1324.306.026		GEAR SHIFT RAIL	1		C01003687E10	1/2	0,000		
100	1324.306.013		GEAR SHIFT FORK	1			1/2*O.UMLENKUNG	0,000		
110	1290.306.066	1000001039	SLIDING PAD	2				0,037		
120	---		ARTICULATION BOLT	2			M18X1,5 SK6	0,000		
---	1346.306.089		ARTICULATION BOLT	2		Z00008927910		0,000		
---	0730.301.379	1882879	SPRING WASHER	2		Z00009160711	19X28 19X28	0,000		
138	1324.306.025		GEAR SHIFT RAIL	1		C01003687E10	R/C W/O INVERSE	0,000		
140	1324.306.039		GEAR SHIFT FORK	1				0,000		
150	1316.306.015	5 5342 0	SLIDING PAD	2		C01009627E10		0,000		
160	---		ARTICULATION BOLT	2			M18X1,5 SK6	0,000		
---	1346.306.089		ARTICULATION BOLT	2		Z00008927910		0,000		
---	0730.301.379	1882879	SPRING WASHER	2		Z00009160711	19X28 19X28	0,000		
180	---		LOCKING LEVER	1		C01004683E10		0,000		
---	1324.306.034	1788146	LOCKING LEVER	1				0,000		
---	1324.306.033		LOCKING LEVER	1			E21	0,000		
190	1304.306.090		BEARING PLATE	1			9/16 S 90 HINTEN WAAGRECHT	0,000		
200	0730.300.430		SNAP RING	1				0,000		
210	0732.041.374	536037A132602	COMPRSPRING	1				0,000		

# Parts list

Page 2 from 2

Material number: 1324.001.098

9 S 1310 TO /

Plant: 062.06.27-1

Material-assembly-group-no: 1324.106.004



Pos.	Material number	Customer material	Name	Quantity	ME	Amend. no.	Techn. Info.	Weight	Rep kit	Alternative material
220	---		SCREW PLUG	1			35N.M*DICHTRING M14X1,5	0,000		
---	0636.100.689		SCREW PLUG	1		Z00010111911	M14X1,5	0,000		
---	0634.801.217		SEALING RING	1			14X20	0,000		
260	---		SWITCH	1			SCHL*45N.M* DICHTRING* BAJONETT* SCHUTZKAPPE	0,000		
---	0501.210.058	1864900531	SWITCH	1			KPL.	0,000		
---	0634.801.062		SEALING RING	1			18X24	0,001		
---	0700.300.427		PROTECTING CAP	1				0,005		
270	0635.460.024		BALL	1		Z00013179811	13	0,000		
600	1304.207.002		PIN	1		Z00013179811	KPL.	0,000		
610	1268.307.170	5004702	GASKET	1		Z00013179811	ENTHALT.IN 1290 306 272(2)	0,000		
620	1304.307.083		PLATE	1		Z00013179811	ENTHALT.IN 1304 307 082(2)	0,000		
630	---		HEXAGON BOLT	2		Z00013179811	M8X28	0,000		
---	0636.016.414	1869864	HEXAGON BOLT	2		Z00007059116	M8X28	0,000		
---	0630.100.295		WASHER	2		Z00007158415		0,000		
640	---		SWITCH	1			OEFF*45N.M* DICHTRING A=1, 5*BAJONETT*A1* SCHUTZKAPPE	0,000		
---	0501.216.474		SWITCH	1		Z00011843810		0,050		
---	0634.801.062		SEALING RING	1		Z00012132910	18X24	0,001		
---	0700.300.427		PROTECTING CAP	1		Z00011843810		0,005		

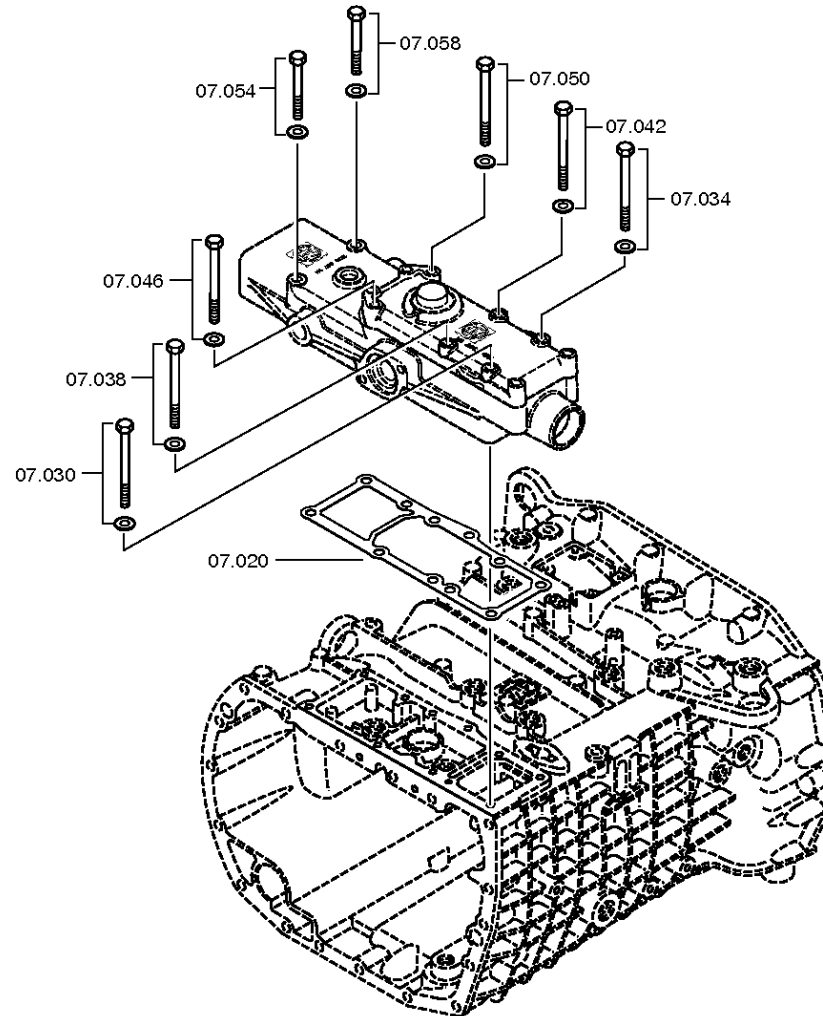

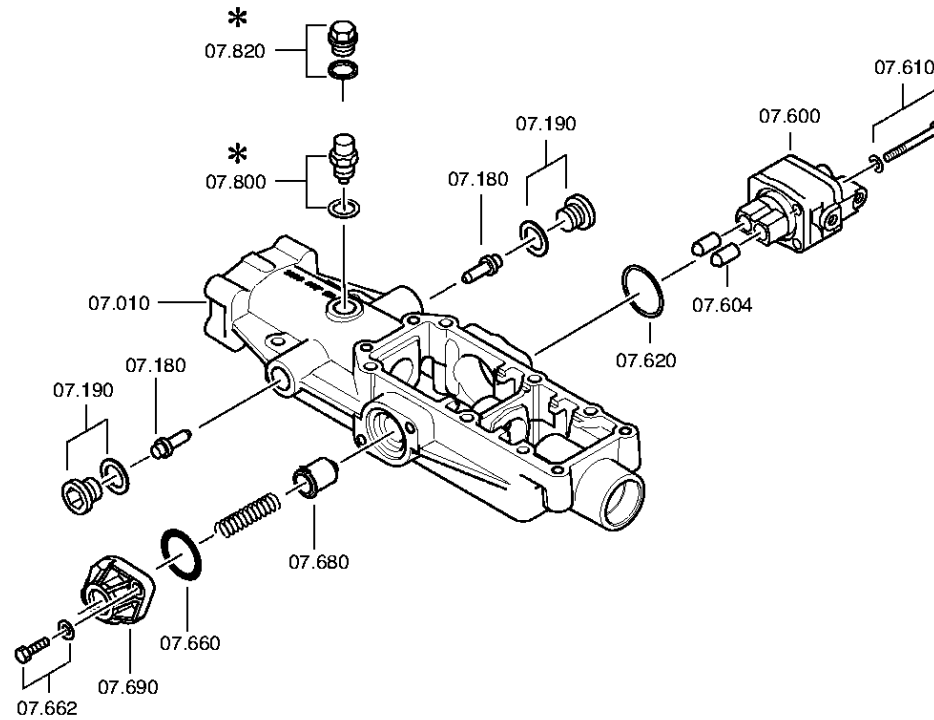



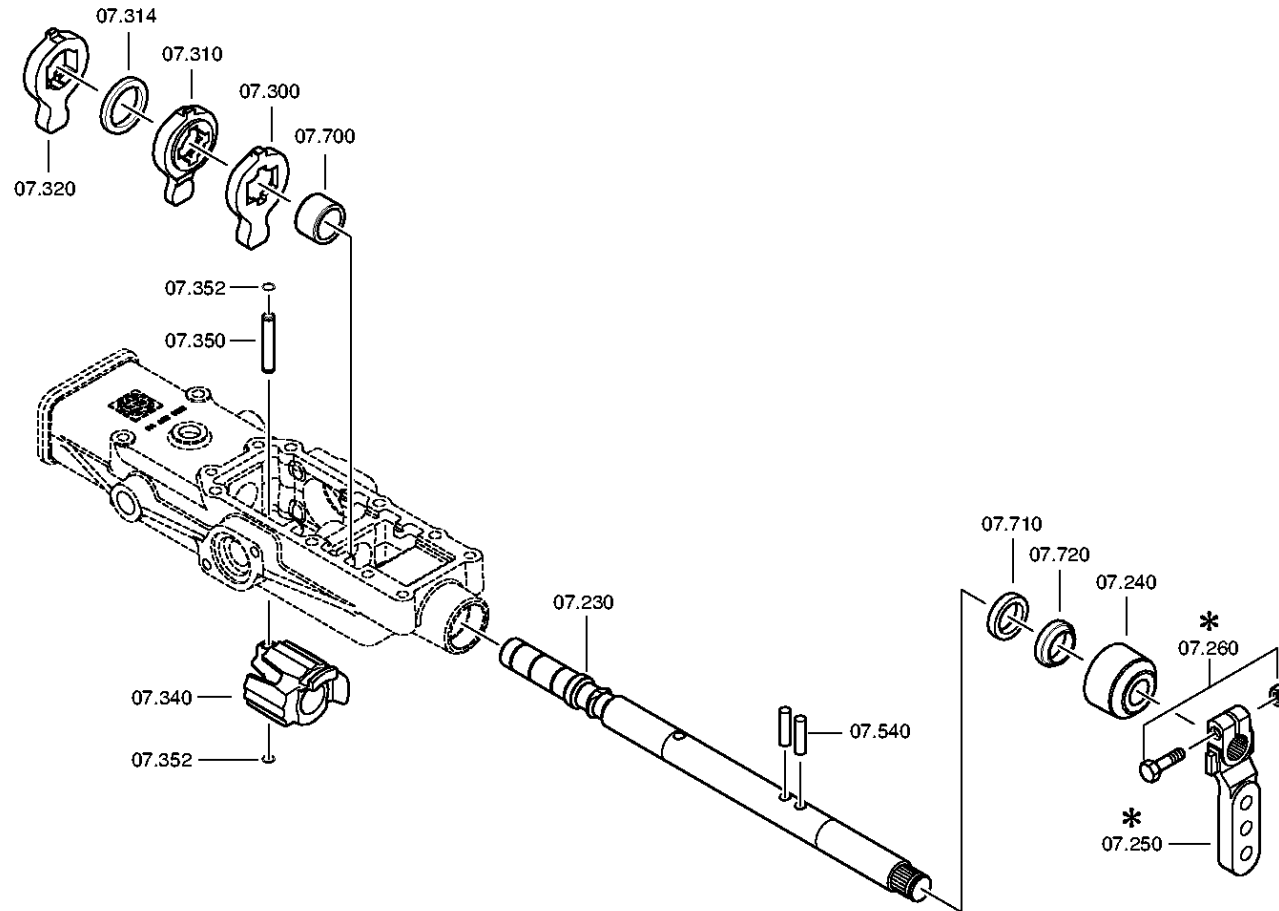

# Parts list

Page 1 from 3

Material number: 1324.001.098

9 S 1310 TO /

Plant: 062.07.85-1

Material-assembly-group-no: 1324.107.800



Pos.	Material number	Customer material	Name	Quantity	ME	Amend. no.	Techn. Info.	Weight	Rep kit	Alternative material
10	1324.307.207		GEAR SHIFT HOUSING	1		Z00003894110		0,000		
20	0501.324.626		GASKET	1				0,000		
30	---		HEXAGON BOLT	1		C01000900F10	M8X100	0,000		
---	0636.011.763		HEXAGON BOLT	1		Z00007053111	M8X100	0,000		
---	0630.100.295		WASHER	1		Z00007158414		0,000		
34	---		HEXAGON BOLT	1		C01000900F10	M8X100	0,000		
---	0636.011.763		HEXAGON BOLT	1		Z00007053111	M8X100	0,000		
---	0630.100.295		WASHER	1		Z00007158414		0,000		
38	---		HEXAGON BOLT	1		C01000900F10	M8X100	0,000		
---	0636.011.763		HEXAGON BOLT	1		Z00007053111	M8X100	0,000		
---	0630.100.295		WASHER	1		Z00007158414		0,000		
42	---		HEXAGON BOLT	1		C01000900F10	M8X100	0,000		
---	0636.011.763		HEXAGON BOLT	1		Z00007053111	M8X100	0,000		
---	0630.100.295		WASHER	1		Z00007158414		0,000		
46	---		HEXAGON BOLT	1		C01000900F10	M8X100	0,000		
---	0636.011.763		HEXAGON BOLT	1		Z00007053111	M8X100	0,000		
---	0630.100.295		WASHER	1		Z00007158414		0,000		
50	---		HEXAGON BOLT	1		C01000900F10	M8X100	0,000		
---	0636.011.763		HEXAGON BOLT	1		Z00007053111	M8X100	0,000		
---	0630.100.295		WASHER	1		Z00007158414		0,000		
54	---		HEXAGON BOLT	1		Z00007052814	M8X75	0,000		
---	0636.100.522		HEXAGON BOLT	1		Z00007052812	M8X75	0,000		
---	0630.100.295		WASHER	1		Z00007158414		0,000		
58	---		HEXAGON BOLT	1		Z00007052814	M8X75	0,000		
---	0636.100.522		HEXAGON BOLT	1		Z00007052812	M8X75	0,000		
---	0630.100.295		WASHER	1		Z00007158414		0,000		
180	1346.307.020	1346307020/DIREKTH Ä./PL1V1	BOLT	2				0,000		
190	---		SCREW PLUG	2		Z00010111513	35N.M*DICHTRING M18X1,5	0,000		
---	0636.100.791		SCREW PLUG	2		Z00010111521	M18X1,5	0,000		

# Parts list

Page 2 from 3

Material number: 1324.001.098

9 S 1310 TO /

Plant: 062.07.85-1

Material-assembly-group-no: 1324.107.800



Pos.	Material number	Customer material	Name	Quantity	ME	Amend. no.	Techn. Info.	Weight	Rep kit	Alternative material
---	0634.801.062		SEALING RING	2		Z00010111521	18X24	0,001		
230	1324.307.134		GEAR SHIFT SHAFT	1		C01008721E10	WL W1	0,000		
240	1324.307.268		PROTECTING CAP	1		Z00009174312		0,000		
250	0637.510.211		PLUG	1				0,000		
300	1324.307.102		DRIVER	1			3/4 GEAR	0,000		
310	1324.307.073		DRIVER	1			1/2 GANG	0,000		
314	0730.113.437		RING	1				0,000		
320	1324.307.287		DRIVER	1		Z00011901710		0,000		
340	1324.307.116		DETENT PART	1		C01008721E10	WB1	0,000		
350	0731.201.767		PIN	1				0,000		
352	0630.513.041		SNAP RING	2				0,000		
540	0731.201.765		CYLINDRICAL PIN	2				0,000		
600	6038.202.045	5 6080 0	CUT-OFF VALVE	1			KPL.H-H* ABLUFTDROSSEL 2,50	0,000		
604	0501.209.188	5 6102 0	BALL ROLLER	2			KPL.	0,000		
610	---		HEXAGON BOLT	4			M8X65	0,000		
---	0636.100.519		HEXAGON BOLT	4		Z00007054112	M8X65	0,000		
---	0630.100.295		WASHER	4		Z00007158414		0,000		
620	0634.313.505		O-RING	1			42X3	0,000		
660	0634.303.332	14000967	O-RING	1			32X4	0,002		
662	---		HEXAGON BOLT	2		Z00007891312	M8X30	0,000		
---	0636.100.797		HEXAGON BOLT	2		Z00007891310	M8X30	0,000		
---	0630.100.295		WASHER	2		Z00007158414		0,000		
680	0501.314.501		STOP PIN	1				0,000		
690	1304.307.331		COVER	1			ENTHALT.IN 1304 307 329(2)	0,000		
700	0730.260.330	5006867	BEARING BUSH	1			A=20,00 IN 0730 260 546(2)	0,000		
710	---		SHAFT SEAL	1				0,000		
---	0634.300.302	5002333	SHAFT SEAL	1			25X35X7	0,000		
---	0734.300.196		SHAFT SEAL	1			25X35X7 FA.CFW	0,000		

## Parts list

Page 3 from 3

Material number: 1324.001.098

9 S 1310 TO /

Plant: 062.07.85-1

Material-assembly-group-no: 1324.107.800



Pos.	Material number	Customer material	Name	Quantity	ME	Amend. no.	Techn. Info.	Weight	Rep kit	Alternative material
720	0634.307.367	2150035300	SCRAPER	1				0,009		
800	---		DETENT PLUNGER	1			153N*50N.M*90GRAD* AUSF.C	0,000		
---	1324.207.028		DETENT PLUNGER	1		Z00009010010	153N	0,000		
---	0730.008.604		SEALING RING	1				0,000		

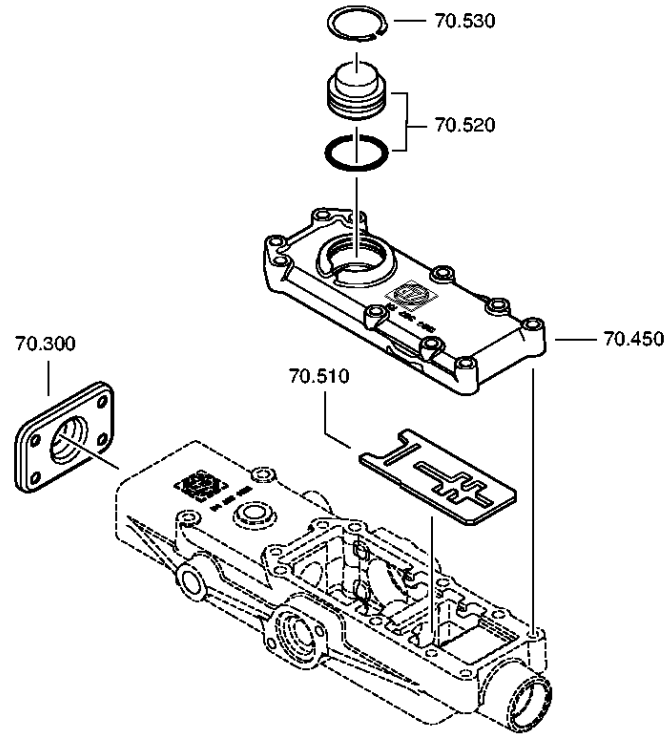

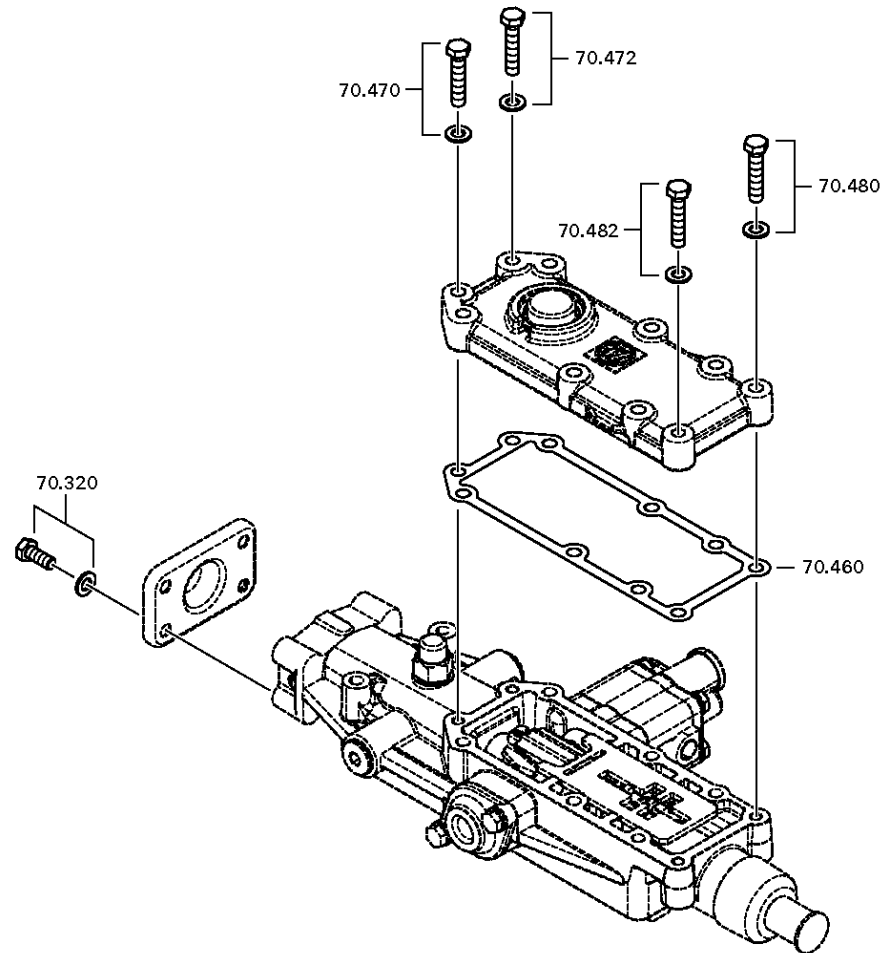

# Parts list

Page 1 from 1

Material number: 1324.001.098

9 S 1310 TO /

Plant: 062.08.22-1

Material-assembly-group-no: 1324.170.011



Pos.	Material number	Customer material	Name	Quantity	ME	Amend. no.	Techn. Info.	Weight	Rep kit	Alternative material
300	1341.307.113		COVER	1		Z00009271410		0,000		
320	---		HEXAGON BOLT	4		Z00007891111	M8X20	0,000		
---	0636.100.796		HEXAGON BOLT	4		Z00007891120	M8X20	0,000		
---	0630.100.295		WASHER	4		Z00007158416		0,000		
450	1324.307.258		COVER	1		Z00008820111		0,000		
460	1324.307.082		GASKET	1			E21	0,000		
470	---		HEXAGON BOLT	1			M8X40	0,000		
---	0636.100.630		HEXAGON BOLT	1		Z00007058610	M8X40	0,000		
---	0630.100.295		WASHER	1		Z00007158414		0,000		
472	---		HEXAGON BOLT	1			M8X40	0,000		
---	0636.100.630		HEXAGON BOLT	1		Z00007058610	M8X40	0,000		
---	0630.100.295		WASHER	1		Z00007158414		0,000		
480	---		HEXAGON BOLT	1			M8X40	0,000		
---	0636.100.630		HEXAGON BOLT	1		Z00007058610	M8X40	0,000		
---	0630.100.295		WASHER	1		Z00007158414		0,000		
482	---		HEXAGON BOLT	1			M8X40	0,000		
---	0636.100.630		HEXAGON BOLT	1		Z00007058610	M8X40	0,000		
---	0630.100.295		WASHER	1		Z00007158414		0,000		
510	1324.307.194		SHIFTING INTERLOCK	1				0,000		
520	0501.318.597		DETENT	1		C01003384F10		0,000		
530	0630.532.130		V-RING	1				0,000		

# Plant

Page 1 from 1

Material number: 1324.001.098

Plant: 062.12.29-1

Material-assembly-group-no: 1324.149.026

9 S 1310 TO /

SET OF SPRINGS

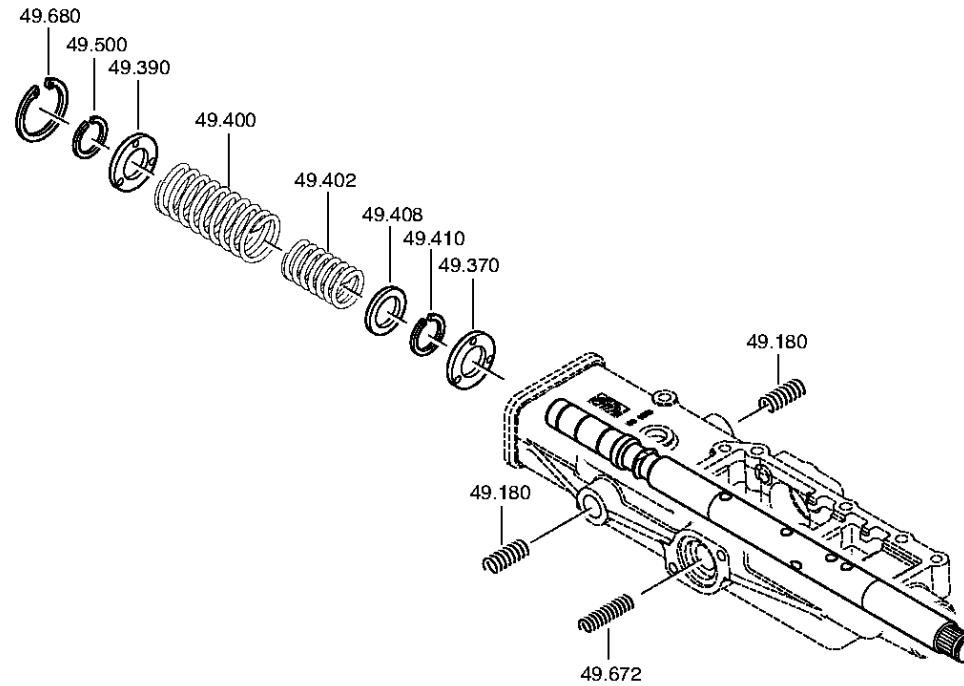



# Parts list

Page 1 from 1

Material number: 1324.001.098

9 S 1310 TO /

Plant: 062.12.29-1

Material-assembly-group-no: 1324.149.026



Pos.	Material number	Customer material	Name	Quantity	ME	Amend. no.	Techn. Info.	Weight	Rep kit	Alternative material
180	0732.041.500		COMPRSPRING	2				0,000		
370	0730.301.376	1884285	WASHER	1		Z00008917410		0,000		
390	0730.301.376	1884285	WASHER	1		Z00008917410		0,000		
400	0732.040.630	0971350020	COMPRSPRING	1				0,000		
402	1204.307.334		COMPRSPRING	1				0,000		
408	---		WASHER	1		Z00011191810		0,000		
410	0630.532.138	5004143	V-RING	1				0,000		
500	0630.532.138	5004143	V-RING	1				0,000		
672	0732.040.819	5 8399 0	COMPRSPRING	1				0,000		
680	0630.502.022		RETAINING RING	1			40X1,75	4,800		

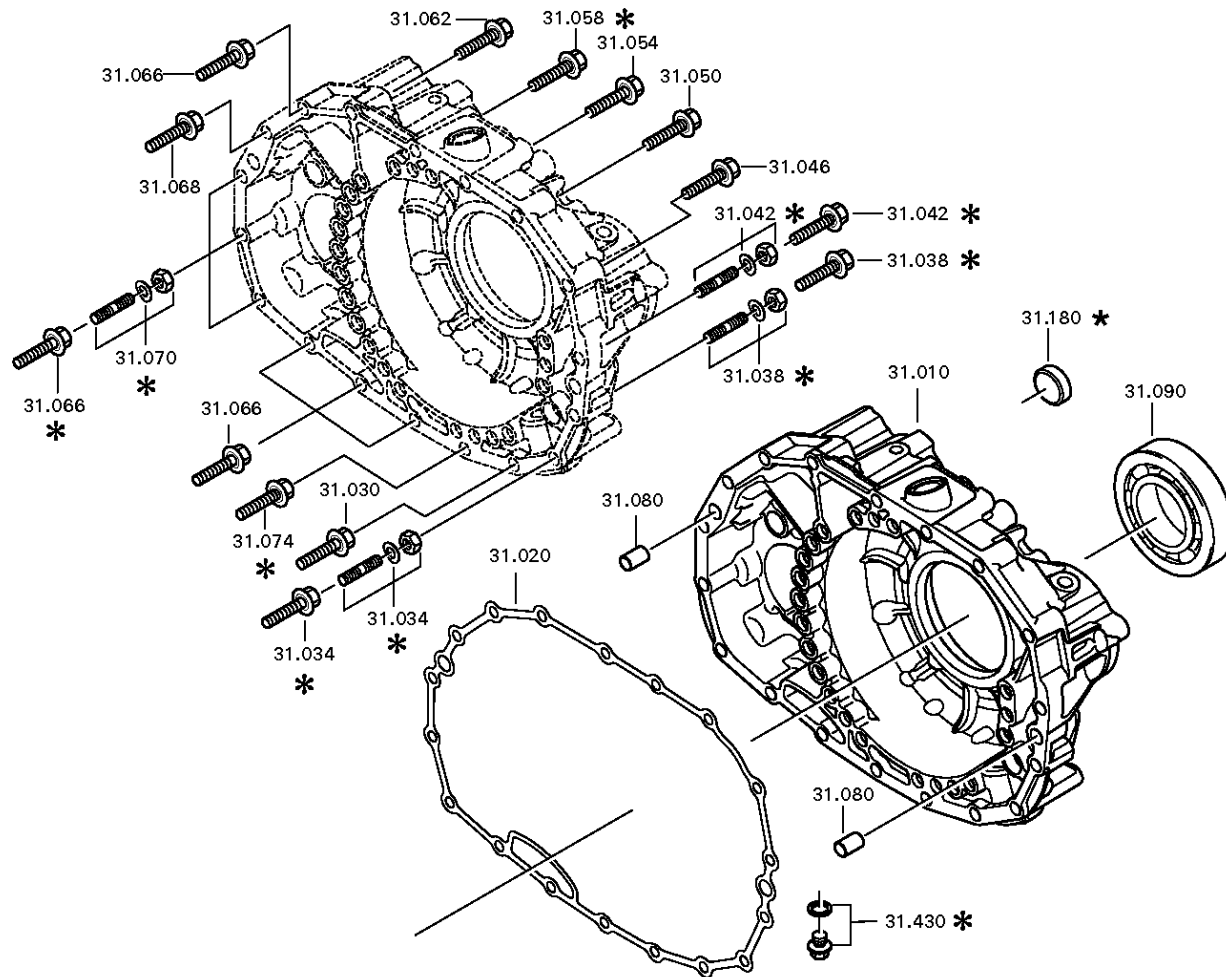

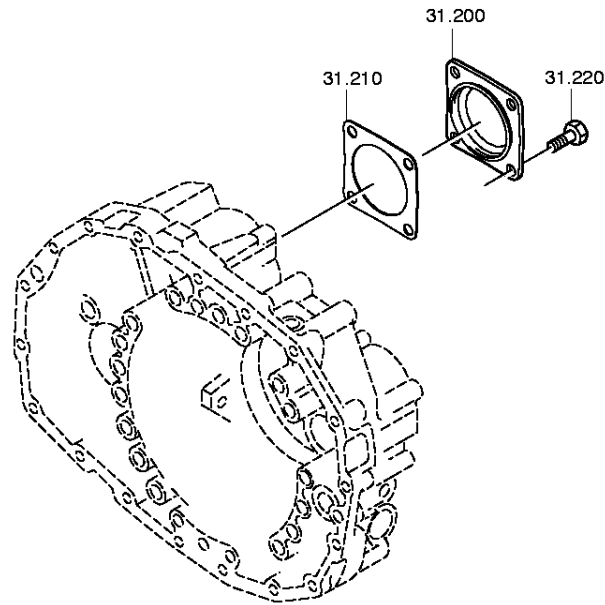

# Parts list

Page 1 from 1

Material number: 1324.001.098

9 S 1310 TO /

Plant: 062.43.09-1

Material-assembly-group-no: 1304.131.069



Pos.	Material number	Customer material	Name	Quantity	ME	Amend. no.	Techn. Info.	Weight	Rep kit	Alternative material
10	1304.301.382		HOUSING III	1		Z00001502414		0,000		
20	1304.301.305		GASKET	1				0,000		
30	0736.300.122		HEXAGON BOLT	1		Z00009403110	M10X110 M10X110	0,000		
34	0736.300.122		HEXAGON BOLT	1		Z00009403110	M10X110 M10X110	0,000		
38	0736.300.123	1880233	HEXAGON BOLT	1			M10X70 M10X70	0,000		
42	0736.300.124		HEXAGON BOLT	1		Z00009402910	M10X50 M10X50	0,000		
46	0736.300.123	1880233	HEXAGON BOLT	1			M10X70 M10X70	0,000		
50	0736.300.123	1880233	HEXAGON BOLT	1			M10X70 M10X70	0,000		
54	0736.300.122		HEXAGON BOLT	1		Z00009403110	M10X110 M10X110	0,000		
58	0736.300.122		HEXAGON BOLT	1		Z00009403110	M10X110 M10X110	0,000		
62	0736.300.123	1880233	HEXAGON BOLT	1			M10X70 M10X70	0,000		
66	0736.300.123	1880233	HEXAGON BOLT	3			M10X70 M10X70	0,000		
68	0736.300.123	1880233	HEXAGON BOLT	1			M10X70 M10X70	0,000		
70	0736.300.123	1880233	HEXAGON BOLT	3			M10X70 M10X70	0,000		
72	0736.300.123	1880233	HEXAGON BOLT	1			M10X70 M10X70	0,000		
74	0736.300.122		HEXAGON BOLT	1		Z00009403110	M10X110 M10X110	0,000		
80	0631.306.229		CYLINDRICAL PIN	2			16X36	0,000		
90	0750.116.404		BALL BEARING	1		Z00001502414	80,0X140,0X26,0	0,000		
200	1328.301.170	1878388	COVER	1		Z00008068012		0,000		
210	1238.308.201	5006880	GASKET	1			ENTHALT.IN 1238 308 202(2)	0,000		
220	0636.016.406		HEXAGON BOLT	4		Z00007061014	M12X25	0,000		

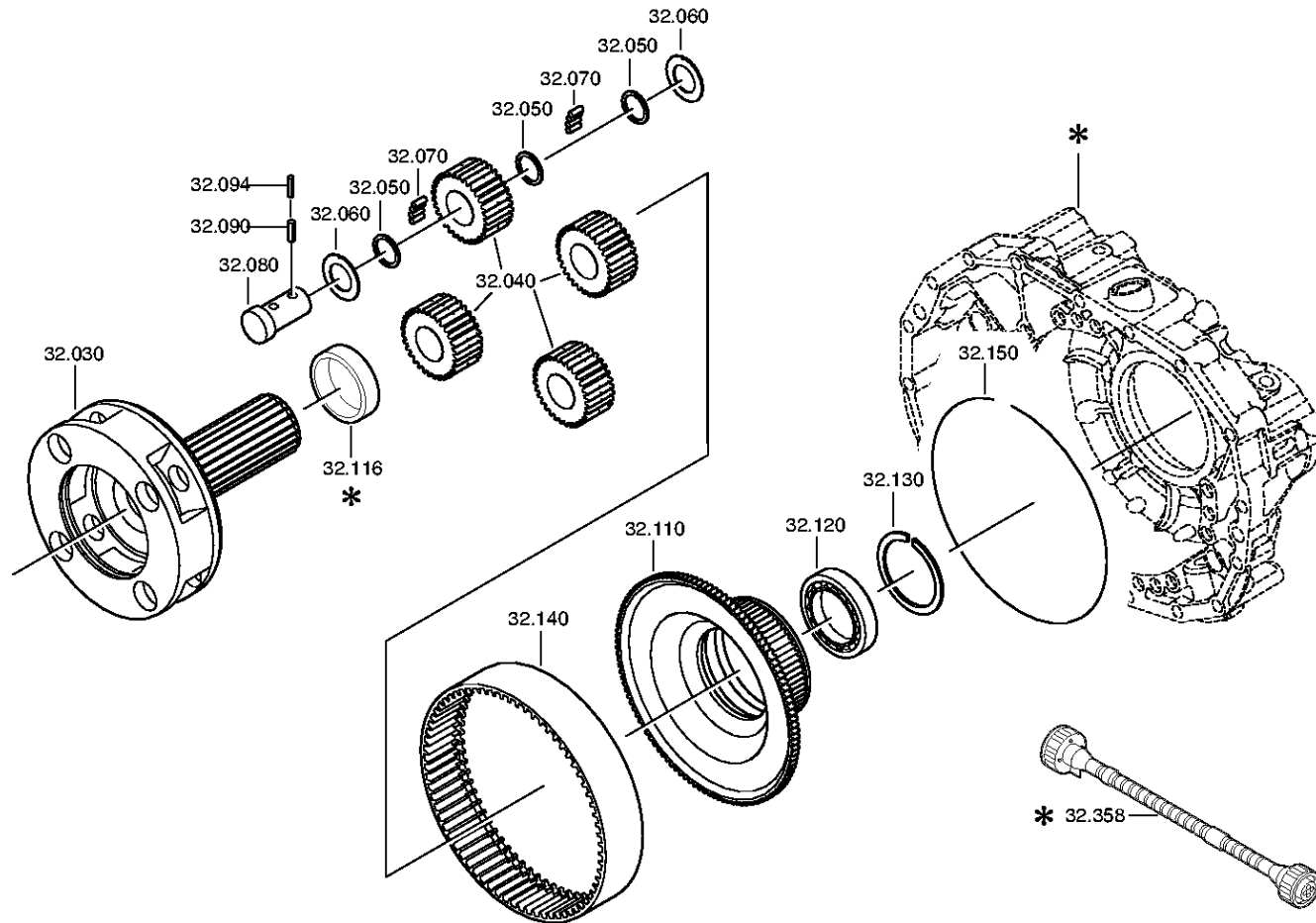

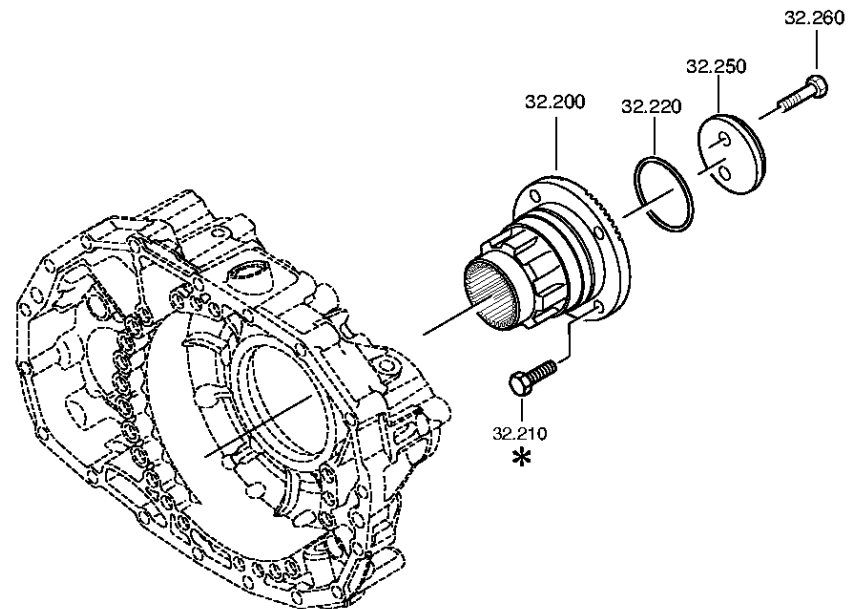

# Parts list

Page 1 from 1

Material number: 1324.001.098

9 S 1310 TO /

Plant: 062.44.13-1

Material-assembly-group-no: 1324.132.003



Pos.	Material number	Customer material	Name	Quantity	ME	Amend. no.	Techn. Info.	Weight	Rep kit	Alternative material
30	1324.232.004		PLANET CARRIER	1			KPL. *NEW ECOMID	0,000		
40	1324.232.002		PLANET GEAR SET	1			KPL.	0,000		
50	0730.103.102		INTERMWASHER	12			A=1,50 IN 0730 105 951(2)	0,000		
60	0730.150.767		WASHER	8		C01003023E10	A=1,50 IN 0501 304 086(2)	0,000		
70	0735.470.115		NEEDLE ROLLER	160			5,0X15,3 FA.INA	0,000		
80	1324.332.016		PLANET SHAFT	4		C01003313F10	9 S 1310	0,000		
90	0631.329.049	T159473	SLOTPIN	4			5X22	2		
94	0631.329.175		SLOTPIN	4			3X22	0,000		
110	1324.332.007		RING GEAR CARRIER	1				0,000		
120	0735.330.804	1823005	BALL BEARING	1			70,0X110,0X13,0 FA.FAG	0,000		
130	---		SNAP RING	1			S= 2,00- 2,50( ABSTUFUNG:0,10MM)	0,000		
---	0730.513.755		SNAP RING	1				0,000		
---	0730.513.756		SNAP RING	1				0,000		
---	0730.513.757		SNAP RING	1				0,000		
---	0730.513.758		SNAP RING	1				0,000		
---	0730.513.759		SNAP RING	1				0,000		
---	0730.513.760		SNAP RING	1				0,000		
140	1324.332.018		RING GEAR	1			ECOMID NEW	0,000		
150	0730.505.053	570439408	LOCKING WIRE	1			A=2,50 IN 0730 505 052(2)	0,000		
200	1304.338.097		OUTPUT FLANGE	1				0,000		
210	---		HEXAGON BOLT	4		Z00004901311	SCHUTZKAPPE M14X1,5X50	0,000		
220	0634.313.223	5 8118 0	O-RING	1			59,2X5,7	0,000		
250	1304.338.045		WASHER	1			ENTHALT.IN 1295 332 063(2)	0,000		
260	0636.016.407		HEXAGON BOLT	2		Z00009111110	M12X50	0,000		

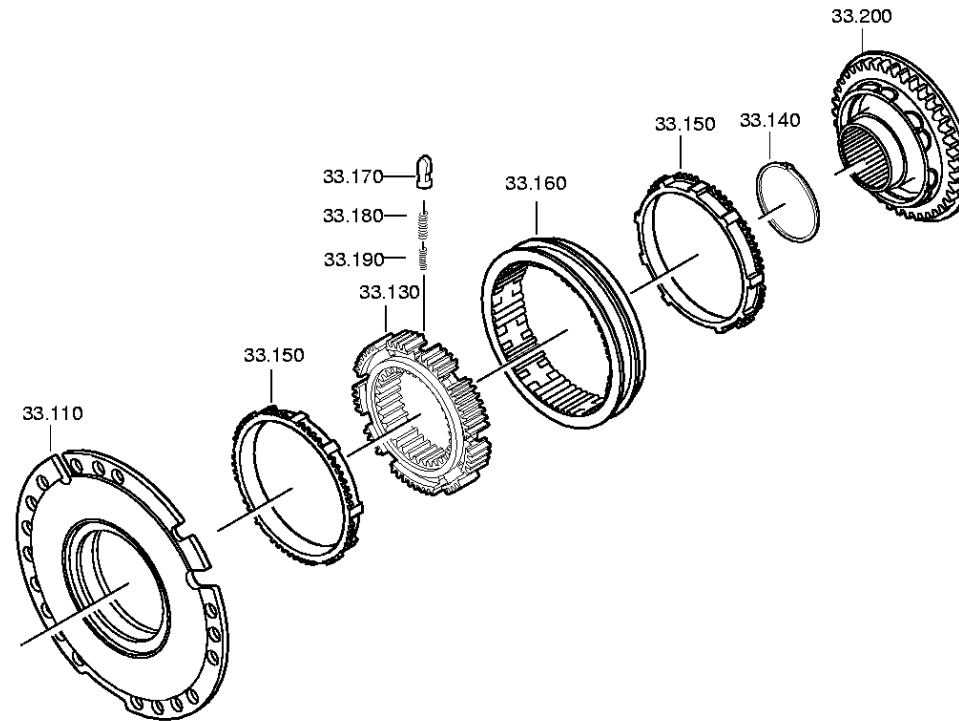



# Parts list

Page 1 from 1

Material number: 1324.001.098

9 S 1310 TO /

Plant: 062.45.05-1

Material-assembly-group-no: 1324.133.001



Pos.	Material number	Customer material	Name	Quantity	ME	Amend. no.	Techn. Info.	Weight	Rep kit	Alternative material
110	1304.233.006		CLUTCH BODY	1				0,000		
130	1313.333.001		SYNCHROBODY	1			ENTHALT.IN 1296 333 014(1)	0,000		
140	---		RETAINING RING	1			S= 3,70- 4,00( ABSTUFUNG:0,10MM)	0,000		
---	0630.501.061		RETAINING RING	1			125X4	0,100		
---	0630.501.173		RETAINING RING	1			125X3,9	0,000		
---	0630.501.174		RETAINING RING	1			125X3,8	0,000		
---	0630.501.175	0692274	RETAINING RING	1			125X3,7	0,000		
150	1296.333.045	5 5301 0	SYNCHRORING	2				0,000		
160	1304.333.011		SLIDING SLEEVE	1			ENTHALT.IN 1304 333 013(0)	0,000		
170	1240.304.278	1334510410	PRESSURE PIECE	9				0,000		
180	0732.040.385	0971040080	COMPRSPRING	9				0,000		
190	0732.040.386	097102000	COMPRSPRING	9		C01007317F10		0,000		
200	1324.233.001		CLUTCH BODY	1				0,000		

# Plant

Page 1 from 2

Material number: 1324.001.098  
Plant: 062.46.09-1  
GP SHIFT SYSTEM

9 S 1310 TO /  
GP SHIFT SYSTEM

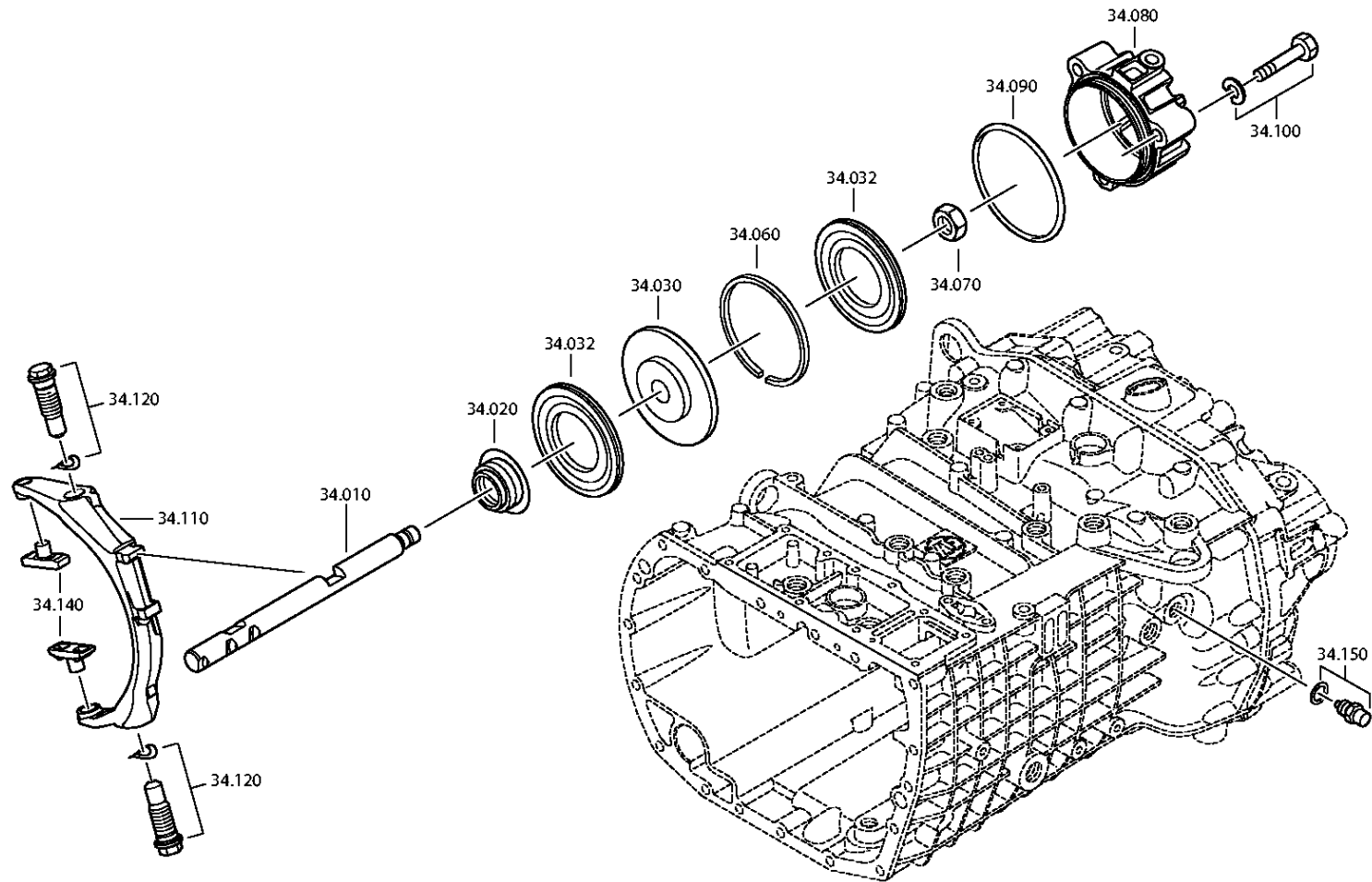

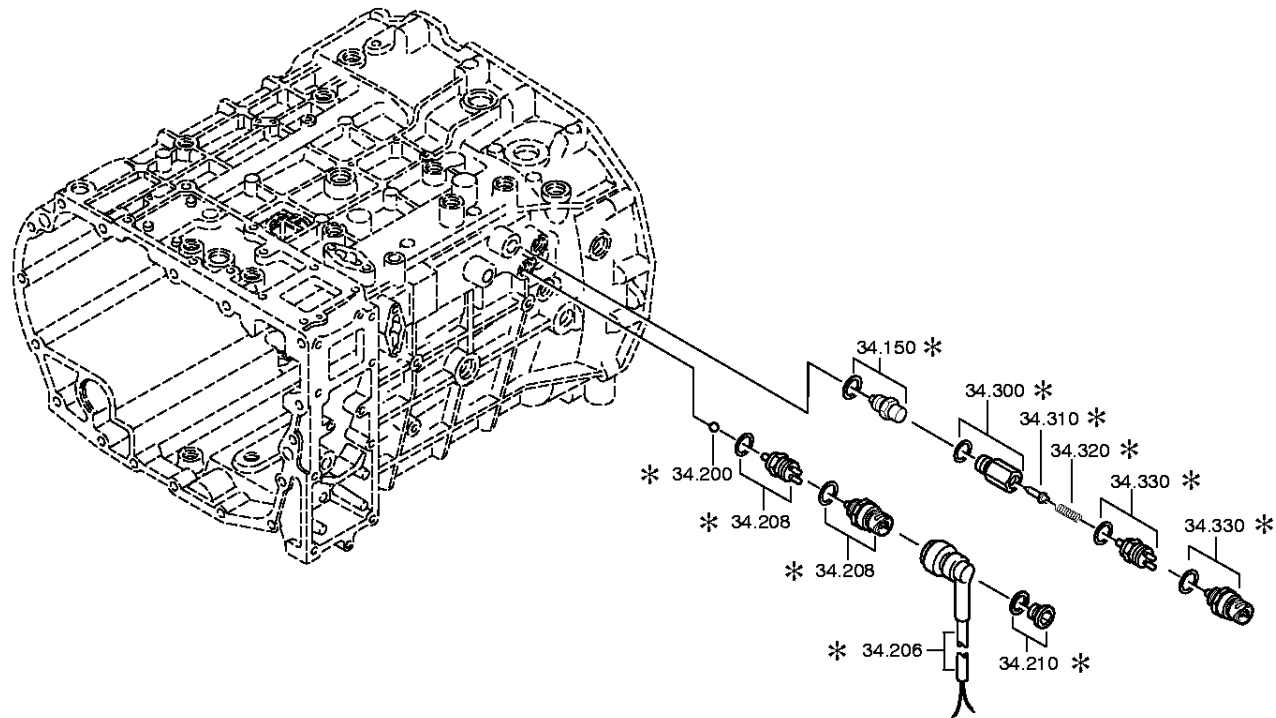

# Parts list

Page 1 from 1

Material number: 1324.001.098

9 S 1310 TO /

Plant: 062.46.09-1

Material-assembly-group-no: 1324.134.004



Pos.	Material number	Customer material	Name	Quantity	ME	Amend. no.	Techn. Info.	Weight	Rep kit	Alternative material
10	1324.334.004		GEAR SHIFT RAIL	1		C01004683E10	GP	0,000		
20	0750.112.047	1722250410	FLANGE PACKING	1			22X36X14,5	0,000		
30	1315.334.041		PISTON	1			ENTHALT.IN 1315 334 040(2)	0,000		
32	0734.307.287	5 8128 0	SEALING RING	2			50X100X7,5 FA.KACO	0,000		
60	0750.112.096	8 8180 0	GUIDE RING	1			95X100X5,6	0,000		
70	0737.300.037		LOCKING NUT	1		Z00008929010	MS16X1,5	0,000		
80	1304.334.079		CYLINDER	1				0,000		
90	0634.313.338	5 8001 0	O-RING	1			108X3	0,000		
100	0736.300.123	1880233	HEXAGON BOLT	3			M10X70 M10X70	0,000		
110	1304.334.063		GEAR SHIFT FORK	1				0,000		
120	---		ARTICULATION BOLT	2		Z00005692510	O.SCHEIBE M24X1,5 SK6	0,000		
---	1315.334.074	1877888	ARTICULATION BOLT	2		Z00004075610		0,000		
140	1272.334.003	5004089	SLIDING PAD	2				0,000		
150	---		DETENT PLUNGER	1			145N*50N.M	0,000		
---	1324.207.035		DETENT PLUNGER	1			KPL. *145 N	0,000		
---	0730.008.604		SEALING RING	1				0,000		
200	0635.460.024		BALL	1			13	0,000		
208	---		SWITCH	1			OEFF*45N.M* DICHTRING A=1, 5*BAJONETT*A1* SCHUTZKAPPE	0,000		
---	0501.216.474		SWITCH	1		Z00011843810		0,050		
---	0634.801.062		SEALING RING	1		Z00012132910	18X24	0,001		
---	0700.300.427		PROTECTING CAP	1		Z00011843810		0,005		

# Plant

Page 1 from 1

Material number: 1324.001.098  
Plant: 062.47.02-1  
SPEEDOMETER COVER

9 S 1310 TO /  
SPEEDOMETER COVER

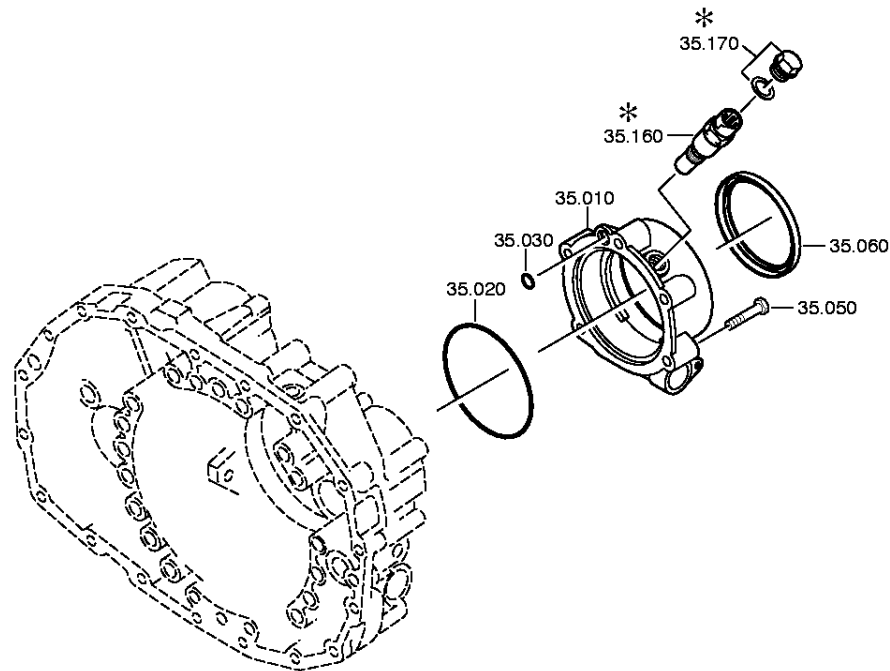

# Parts list

Page 1 from 1

Material number: 1324.001.098

9 S 1310 TO /

Plant: 062.47.02-1

Material-assembly-group-no: 1304.135.014



Pos.	Material number	Customer material	Name	Quantity	ME	Amend. no.	Techn. Info.	Weight	Rep kit	Alternative material
10	1304.301.410		SPEEDOMETER COVER	1				0,000		
20	0634.303.110	1000004998	O-RING	1			138X3	3,900		
30	0634.316.181		O-RING	1			10X3	0,000		
50	0636.016.405		HEXAGON BOLT	5		Z00007060112	M10X60	0,000		
60	0734.319.459	8 8309 0	SHAFT SEAL	1			105X125X12/9,5 FA.CFW	0,000		
160	---		PULSE SENSOR	1			45N.M*O.DICHTRING* BAJONETT* SCHUTZKAPPE*L=19,8	0,000		
---	0501.210.855		PULSE SENSOR	1				0,090		
---	0700.300.427		PROTECTING CAP	1				0,005		

# Plant

Page 1 from 1

Material number: 1324.001.098

Plant: 062.57.02-1

Material-assembly-group-no: 1324.145.015

9 S 1310 TO /

RANGE SELECTION

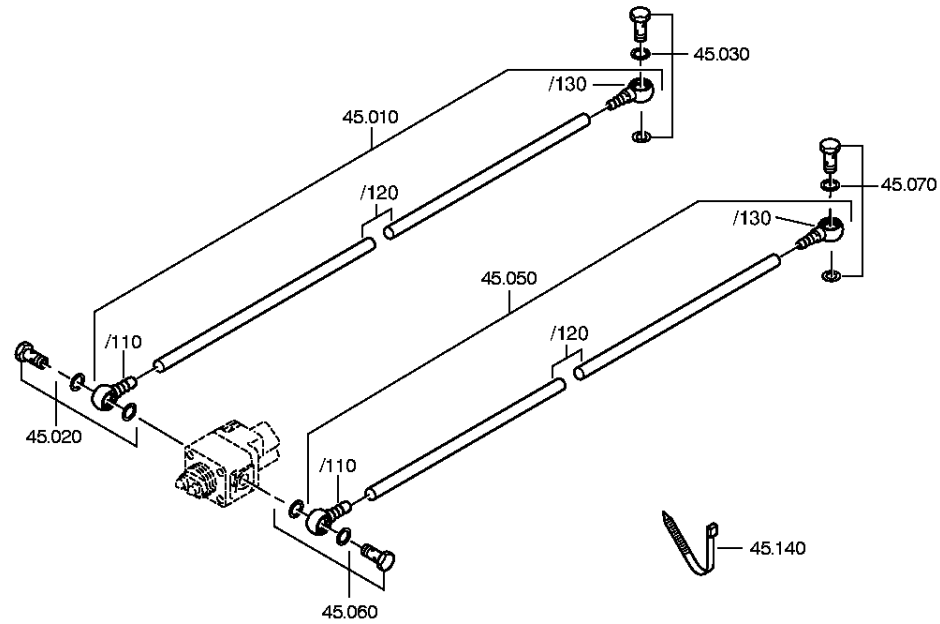

# Parts list

Page 1 from 1

Material number: 1324.001.098

9 S 1310 TO /

Plant: 062.57.02-1

Material-assembly-group-no: 1324.145.015



Pos.	Material number	Customer material	Name	Quantity	ME	Amend. no.	Techn. Info.	Weight	Rep kit	Alternative material
10	6007.202.226		PIPE	1		Z00011016211	KPL.490MM* MONTAGE:STELLUNG A	0,000		
/110	0637.100.423		RING PIECE	1		Z00011016211		0,000		
/120	0632.702.470	5007351	PIPE	490		Z00011016211	8X1,5	0,000		
/130	0637.100.423		RING PIECE	1		Z00011016211		0,000		
20	---		UNION SCREW	1		Z00011016211	M14X1,5	0,000		
---	0737.300.061		UNION SCREW	1		Z00012473710	M14X1,5	0,000		
---	0634.801.217		SEALING RING	1		Z00010274513	14X20	0,000		
30	---		UNION SCREW	1		Z00011016211	M14X1,5	0,000		
---	0737.300.061		UNION SCREW	1		Z00012473710	M14X1,5	0,000		
---	0634.801.217		SEALING RING	1		Z00010274513	14X20	0,000		
50	6007.202.227		PIPE	1		Z00011016211	KPL.550MM* MONTAGE:STELLUNG A	0,000		
/110	0637.100.423		RING PIECE	1		Z00011016211		0,000		
/120	0632.702.470	5007351	PIPE	550		Z00011016211	8X1,5	0,000		
/130	0637.100.423		RING PIECE	1				0,000		
60	---		UNION SCREW	1		Z00011016211	M14X1,5	0,000		
---	0737.300.061		UNION SCREW	1		Z00012473710	M14X1,5	0,000		
---	0634.801.217		SEALING RING	1		Z00010274513	14X20	0,000		
70	---		UNION SCREW	1		Z00011016211	M14X1,5	0,000		
---	0737.300.061		UNION SCREW	1		Z00012473710	M14X1,5	0,000		
---	0634.801.217		SEALING RING	1		Z00010274513	14X20	0,000		
140	0659.160.068		CABLE CLIP	2		Z00011016211		0,000		
142	0659.100.242		DOWEL	1		Z00011016211		0,000		



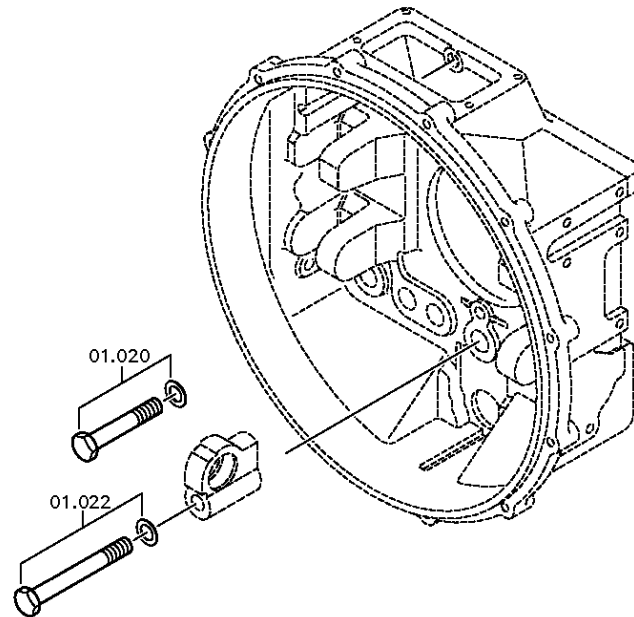

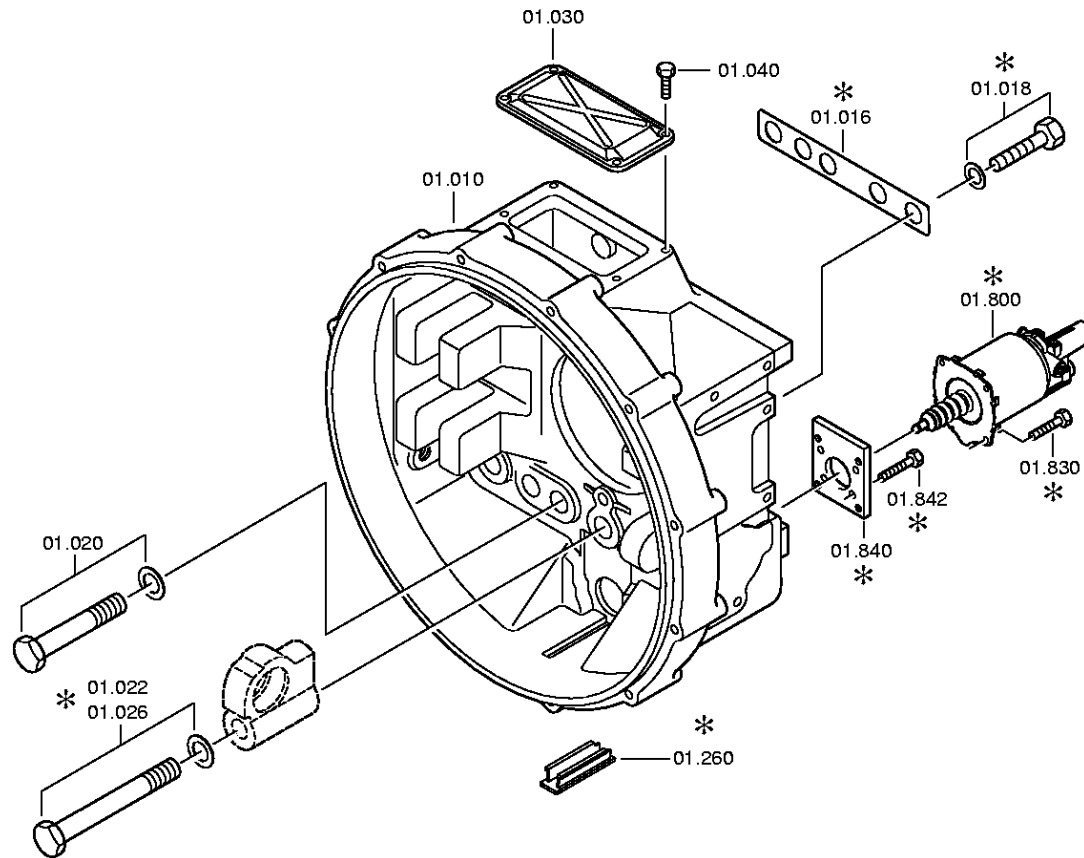

# Parts list

Page 1 from 1

Material number: 1324.001.098

9 S 1310 TO /

Plant: 061.92.78-1

Material-assembly-group-no: 6060.101.840



Pos.	Material number	Customer material	Name	Quantity	ME	Amend. no.	Techn. Info.	Weight	Rep kit	Alternative material
10	6060.201.249		BELL HOUSING	1			KPL. IN 6060 201 248(1)	0,000		
18	---		HEXAGON BOLT	1			ZF KAMA M12X35	0,000		
20	---		HEXAGON BOLT	9		C01000369B10	M18X1,5X85	0,000		
---	0636.100.547		HEXAGON BOLT	9		Z00007061910	M18X1,5X85	0,000		
---	0630.001.021		WASHER	9				0,000		
22	---		HEXAGON BOLT	1		C01009300A10	M18X1,5X160	0,000		
---	0636.100.552		HEXAGON BOLT	1		Z00007062011	M18X1,5X160	0,000		
---	0630.001.021		WASHER	1				0,000		
30	0501.317.373		COVER	1				0,000		
40	0636.100.621		HEXAGON BOLT	4		Z00009560910	M8X12	0,000		
212	---		PLUG	4			GPN 300*F 19 D=20,7	0,000		
---	0637.510.568		PLUG	4				0,000		
---	---		ADHESIVE	4			LOCTITE NR.325 / LOCTITE NR.326	0,000		
---	0666.690.083		ADHESIVE	4				0,000		
---	0666.690.066		JOINCOMPOUND	4				0,000		
260	0501.306.828		SEALING CAP	1				0,000		
800	0501.006.795	5 6082 0	CLUTCH CYLINDER	1				0,000		
830	0636.100.788		HEXAGON BOLT	4		Z00007891612	M8X14	0,000		
840	6060.201.221	04226911	INTERMPLATE	1				0,000		
842	0636.100.796		HEXAGON BOLT	4		Z00007891111	M8X20	0,000		

# Plant

Page 1 from 1

Material number: 1324.001.098

Plant: 061.93.30-1

Material-assembly-group-no: 6060.168.001

9 S 1310 TO /

CLUTCH RELEASE DEVICE

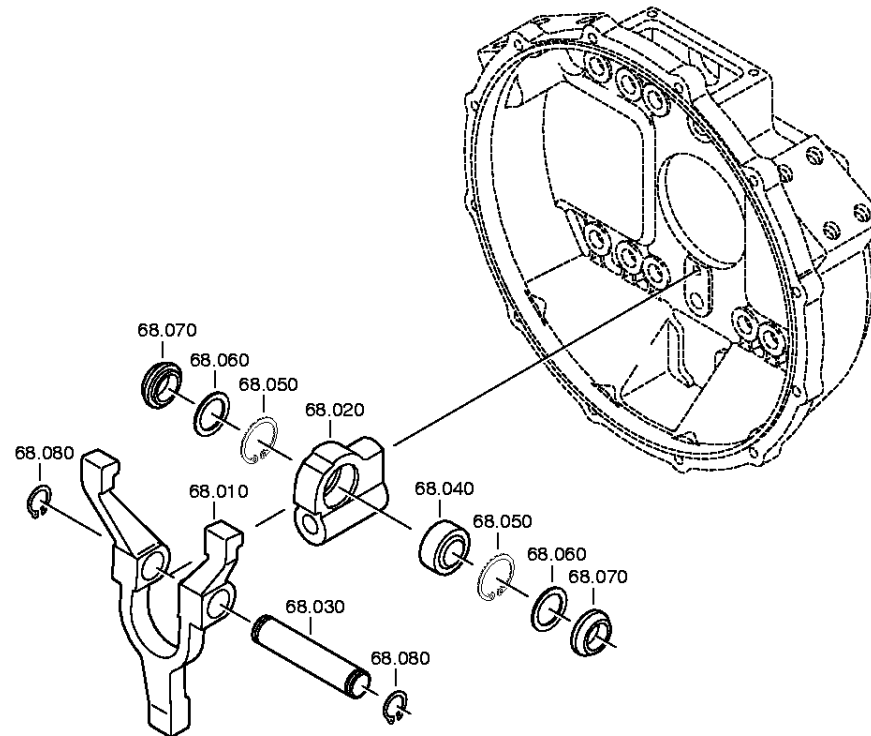

# Parts list

Page 1 from 1

Material number: 1324.001.098

9 S 1310 TO /

Plant: 061.93.30-1

Material-assembly-group-no: 6060.168.001



Pos.	Material number	Customer material	Name	Quantity	ME	Amend. no.	Techn. Info.	Weight	Rep kit	Alternative material
10	6060.206.006	04226929	RELEASE FORK	1			KPL.	0,000		
20	6060.306.096	04226930	BRACKET	1		C01008310A10		0,000		
30	6060.306.086	04226931	PIN	1			ENTHALT.IN 0731 201 607(2)	0,000		
40	0635.285.060		JOINT BEARING	1		C01009510B10		0,000		
50	0630.502.023		RETAINING RING	2			42X1,75	0,010		
60	0501.315.198	04226935	SEALING RING	2				0,000		
70	6060.306.087	5 6099 0	SEALING WASHER	2				0,000		
80	0630.501.020	ZM 7094920	RETAINING RING	2			25X1,2	1,800		